

Operating instructions

Translation of the original operating instructions

Prestige Fusion Edge

1034386-00 / en / 11.2025

Ergoline

Legal notice



Manufacturer: JK-Products GmbH
Köhlersshohner Straße 60
53578 Windhagen
GERMANY
Tel: +49 (0) 22 24 / 818-0

Customer service / JK-International GmbH,
Technical service Division JK-Global Service
(Spare part orders Köhlersshohner Straße 60
for components): 53578 Windhagen
GERMANY
Tel: +49 (0) 22 24 / 818-861
E-mail: service@jk-globalservice.de

Spare part orders for JK-International GmbH,
consumables: Division JK-Licht
Köhlersshohner Straße 60
53578 Windhagen
GERMANY
Tel: +49 (0) 22 24 / 818-600
E-mail: info@jk-licht.de

DANGER!



Failure to observe these operating instructions:

- may result in serious injury and death,
- can result in damage to the unit and to the environment.
- Read these instructions carefully before putting this unit into operation.
- Please observe the instructions and the code of conduct required to operate the unit safely.
- Please make the operating instructions and additional information from the manufacturer available to the personnel at their workplace.
- Should you sell this unit or give it to another party, please make sure that you provide them with these operating instructions.

Copyright

The copyright remains with JK-Holding GmbH.

The contents may not be partially or completely duplicated, distributed or utilized for competitive purposes without authorization or disclosed to other parties.

The right to make technical changes in regard to the figures and information contained in these operating instructions is reserved!

Table of contents



1	Safety instructions and warnings	6
1.1	General	6
1.1.1	Definitions	6
1.1.2	Symbol explanation	7
1.2	Intended use	8
1.3	Foreseeable misuse	8
1.4	Tanning safety information	9
1.4.1	Prohibited usage	9
1.4.2	Important notes	10
1.4.3	Skin type descriptions	12
1.4.4	Tanning times EN	13
1.5	Safety instructions and warnings	14
1.5.1	Operator's obligations	14
1.5.2	Personnel training	14
1.5.3	Scope of delivery	14
1.5.4	Transport, assembly and setup	15
1.5.5	Commissioning	17
1.5.6	Operation and maintenance	17
1.5.7	Decommissioning	18
1.5.8	Storage	18
1.5.9	Disposal	19
1.5.10	Directives	20
1.5.11	Export	20
1.5.12	Own music	20
1.5.13	Technical modifications	21
1.6	Signs and stickers on the unit	22
1.7	Preclusion of damage	28
1.8	Exclusion of liability	28
2	Description	29
2.1	Scope of delivery	29
2.1.1	Options	29
2.2	Equipment	29
2.3	Unit description	30
2.4	Accessories (optional)	32
2.5	Functional description	32



3	Operation.....	33
3.1	User safety information	33
3.2	Tanning - but correctly!	33
3.3	Operating overview.....	35
3.3.1	PROFESSIONAL SETUP MANAGER PLUS	36
3.3.2	NFC Connect.....	37
3.4	Functions	38
3.4.1	EXTERIOR DISPLAY	40
3.4.2	INTERIOR DISPLAY.....	43
3.5	Selection of the application type (SELECTABLE TANNING PROGRAMS)	48
3.6	Start.....	48
3.7	Coupling with Bluetooth® devices	49
3.8	Listening to music	52
3.9	Smartphone Wireless Charging.....	52
4	Cleaning and maintenance.....	53
4.1	Safety instructions when undertaking cleaning or maintenance work	53
4.2	Faults.....	54
4.3	Cleaning	54
4.3.1	Cleaning the surfaces	55
4.3.2	Filter panels and lamps.....	55
4.4	Cleaning plan	56
4.5	Maintenance	57
4.5.1	Acrylic glass.....	57
4.6	REMOTE SERVICE (optional)	58
4.7	Maintenance plan	58
4.8	Cleaning and maintenance work preparation.....	62
4.8.1	Service kit.....	62
4.8.2	Lift up the acrylic glass panel and remove the partition	63
4.8.3	Removing the canopy panel.....	64
4.8.4	Removing the side section panel	65
4.8.5	Opening the bed base	66
4.9	Instructions for replacing the lamps	67
4.9.1	NFC: Lamp replacement	68
4.9.2	Low-pressure lamps.....	69
4.9.3	Starter.....	70
4.9.4	High pressure lamps and filter panels	71
4.10	Cleaning or replacing lamps in the base.....	72
4.11	Cleaning or replacing the lamps in the side section	73
4.12	Cleaning or replacing lamps and filter panels in the canopy	74
4.13	Cleaning the filters in the base	76
4.14	Cleaning the canopy filter mats.....	77
4.15	Air conditioning: Empty the condensation tank and cleaning the filter.....	78

4.16	AQUA / AROMA system maintenance	81
4.16.1	Changing the AROMA canister	81
4.16.2	Replacing the AQUA SYSTEM canister	82
5	Technical data	84
5.1	Power, connection rating and noise level	84
5.2	Dimensions	85
5.3	Lamp sets.....	86
5.3.1	Prestige Fusion Edge.....	86
5.4	Spare parts and accessories	88
6	Appendix	89
6.1	JK timer controls	89
6.2	Equivalence key range.....	89
6.2.1	Description of the equivalence keys for fluorescent lamps	90
7	Index.....	91



1 Safety instructions and warnings



To ensure safe operation of the device, it is necessary to read the following safety instructions and warnings carefully and comply with them.

These instructions should be retained for future use.

The safety instructions summarized here are repeated in the corresponding chapters, where necessary.

1.1 General

1.1.1 Definitions

Operator

Person who provides the devices described here to users on a commercial basis. The operator is responsible for the correct operation of the device as well as compliance with the maintenance intervals.

User

A person who uses the device at a commercial location.

Personnel

People who are responsible for the operation, cleaning and general maintenance work and who instruct the users in the operation of the devices.

Electrician

A person with suitable professional training, knowledge, experience and knowledge of the applicable regulations which enable them to identify and avoid the dangers which can arise from working with electricity.

Authorized, trained and qualified personnel

Qualified staff from an external company who have been trained and authorized by the manufacturer to undertake assembly and maintenance work on specific equipment.

1.1.2 Symbol explanation

The following types of safety notices are employed in these operating instructions:



 DANGER!



Type and source of hazard

This safety notice indicates the existence of a direct danger to body and life.

 DANGER!



Type and source of hazard

This safety notice warns of dangers to body and life which are caused by electricity.

 WARNING!



Type and source of hazard

This safety notice warns of machine, material or environmental damage.

 WARNING!



Type and source of hazard

This safety notice warns of flammable substances.



NOTE:

This symbol does not identify any safety notices, but provides additional information to better understand the processes.



1.2 Intended use

This unit serves the purpose of cosmetic tanning for one adult person with skin suitable for tanning. More detailed information can also be found on pages 12 and 33.

This device is intended only for commercial use and not for private use.

Some people are not permitted to use the device, see page 9.

The device may not be used by people with reduced physical, sensory or mental capabilities or who have insufficient experience and/or knowledge without supervision. A person responsible for their safety must ensure, either by supervision or instruction, that the device is used correctly and safely. If there is any doubt, use of the device by such categories of persons is to be forbidden!

The device may only be operated with the specified or equivalent lamps. The tanning times given in this instruction manual are valid only for the specified lamp set.

Any other use shall be considered improper. The manufacturer cannot be held liable for damage or injuries resulting from this. The operator bears the sole risk for this.

Proper use also includes compliance with the manufacturer's instructions and its operating and maintenance conditions. The unit may only be operated, maintained and repaired by trained professionals familiar with this unit and who have been informed of the dangers involved.

1.3 Foreseeable misuse

The following uses of the device are explicitly prohibited:

- The device may not be used by several people at the same time. The acrylic glass panel may otherwise break and cause injuries.
- People with a body weight of more than 135 kg may not use the device. The acrylic glass panel may otherwise break and cause injuries.
- Exceeding the specified tanning times may result in burns and long-term skin damage.
- When the device is in use no other people may remain in the cabin, in particular no children.
- While using the device no pets may be present in the cabin.

1.4 Tanning safety information

1.4.1 Prohibited usage



 DANGER!



UV radiation
Danger of skin and eye injuries or skin diseases!
- Please observe the following instructions.

The following people may not use the device:

- People under 18 years of age
- People who cannot tan
- People who cannot tan in the sun without risking a sunburn
- People who easily sunburn when in the sun
- People with acute sunburn
- People who repeatedly suffered from serious sunburn during childhood
- People with naturally red hair
- People with atypically discoloured areas of skin
- People who have or have had skin cancer
- People who suffer from an increased risk of skin cancer (e.g. cases of skin cancer in the family)
- People among whose closest relatives a melanoma has occurred
- People who are being medically treated for photosensitivity
- People taking photosensitivity causing medicine
- People with freckles and people who tend to develop freckles
- People with more than 16 moles on their body (2 mm diameter or larger)
- People with atypical moles (atypical moles are, for example, asymmetrical moles with a diameter greater than 5 mm, with varying pigmentation and irregular edges)
- Seek medical advice without fail if in doubt!



The following people may only use the device after consultation with their doctor:

- People with chronic illnesses, in particular those related to the skin
- People with illnesses of the immune system / auto-immune diseases
- People with collagenosis (e. g. lupus erythematoses, scleroderma)
- People suffering from rosacea (copper rose)
- People with spider veins (e. g. couperose, Osler's disease, spider nevi)
- People with low blood pressure, cardiovascular diseases
- People suffering from venous diseases
- People suffering from cancer
- People with fresh wounds following an operation or surgery
- People with tattoos or piercings which have not fully healed
- Pregnant women

Should there be any doubt with regard to compatibility, despite no known medical side effects, a test application of a maximum of 5 minutes should be initially carried out and the reactions observed. If no adverse reactions are found after 48 hours, normal application may be begun.

1.4.2 Important notes

All other people must observe the following instructions:

Danger of skin and eye injuries or skin diseases!

- The skin can become sunburnt when exposed to excessive radiation. Excessive, frequently repeated UV radiation exposure from natural sunlight or UV devices can result in premature ageing of the skin and an increased risk of skin tumours.
- Particular caution is advisable for individuals who are especially sensitive to UV radiation, and when certain medicaments or cosmetics are used. Seek medical advice without fail if in doubt!
- Seek medical advice if any unexpected consequences, such as itching, occur within 48 hours of the first tanning session.
- Increasing tanning requires increased exposure time (= radiation time) or after a certain degree of tanning has been achieved, increased tanning is not possible. However, the radiation time may not be extended as desired within the scope of the permissible radiation doses! Therefore, only a certain level of final tanning, which depends on the skin type, can be achieved without endangering your health.
- The tanning unit must never be used when the housing is broken or damaged, when a filter panel is missing or damaged, or the timer is defective!

Behaviour before, during and after a sunbath:

- During the tanning session no other people may remain in the cabin, in particular no children.
- Remove all jewellery (including piercings) before the tanning session.
- Remove cosmetics before tanning and do not use sun screen products.
- Do not use any products intended to accelerate tanning.
- UV light can cause irreversible skin or eye damage. The unprotected eye can become inflamed on the surface, and in certain cases the retina can be damaged by excessive radiation. Cataracts can form after numerous repeated tanning sessions. Use the UV-impermeable protective goggles provided (order no. 1027211-..). Contact lenses and sun glasses are no substitutes for protective glasses.
- Protect sensitive skin areas such as scars, tattoos and genitals before tanning.
- Observe the recommended tanning times.
- During a tanning session the quantity of radiation which results in the skin reddening (MED, minimum erythema dose) may not be exceeded. If reddened skin occurs around 16-24 hours after the tanning session you may not use the tanning device again for one week. After one week you can start again from the beginning with the first tanning session in accordance with the tanning table.
- The time between the first two sessions on the sunbed must be at least 48 hours! Do not take an additional sunbath on the same day.
- See a doctor if stubborn swelling, sores or pigmented moles form on the skin.





1.4.3 Skin type descriptions

 **DANGER!**







Burns and long-term damage!
 People with skin type I may not use the tanning device.
 The following applies to people with skin types II, III and IV:

- Observe the tanning times.
- Observe the safety instructions.



NOTICE:
 The tanning times are only valid for the lamp set and filter panels specified on the lamp set sticker.
 The tanning sessions should be at least 48 hours apart.
 The maximum dosage of 25 kJ/m² per year should not be exceeded.
 The maximum dosage is weighted according to NMSC.¹

Skin type I	Skin type II	Skin type III	Skin type IV
			
Sensitive skin	Light skin	Normal skin	Dark skin
Always/frequently burns	Usually burns	Sometimes burns	Rarely burns
Tolerates only a small amount of natural sun.	Tolerates approx. 10-20 min. of natural sun.	Tolerates approx. 20-30 min. of natural sun.	Tolerates approx. 40 min. of natural sun.

¹ NMSC: Non Melanoma Skin Cancer

1.4.4 Tanning times EN



NOTICE:

People with skin type I should not use the device.

- Observe the tanning times



Observe the national requirements!

The tanning dosage of 3 kJ/m² per programme of tanning sessions should not be exceeded.

The maximum tanning time must not exceed 33.

The tanning sessions must be at least 48 hours apart.

The maximum tanning minutes per year should not exceed 833 minutes.

Prestige Fusion Edge:

- UV low-pressure lamps
ERGOLINE TREND ADVANCED 80-200 EP104 160W R 1511231-..
- Low-pressure lamps SMART SUN R 28 80-200 160W 1518419-..

Number of tanning sessions	Skin type I [min]	Skin type II [min]	Skin type III [min]	Skin type IV [min]
1	–	5	5	5
2	–	11	11	11
3	–	13	13	13
4	–	13	13	13
5	–	16	16	16
6	–	16	16	16
7	–	20	20	20
8	–	22	22	22
9	–	25	25	25
10	–	25	25	25



NOTICE:

According to standard EN 60335-2-27:2013 the tanning table is not depending on skin types.

Identical tanning times are valid for all skin types, with the exception of skin type I.



1.5 Safety instructions and warnings

1.5.1 Operator's obligations

As the operator you are responsible for providing clear operating, cleaning and maintenance instructions and ensuring the intended use and the proper operation of the unit by means of training and instruction for the personnel.

Your operating instructions must enable the safe use and safe operation of the unit and take into account the characteristics and expertise of your company and also the national work safety and environmental protection regulations (within the European Union, the EU directive 89/391/EEC).

1.5.2 Personnel training

As the operator you are obliged to train your personnel and instruct them in the established legal and accident prevention regulations. Ensure that your personnel have understood and observe these operating instructions. This applies in particular to the

- information in 'Intended use' and 'Foreseeable misuse'
- safety instructions in the 'Operation' chapter
- operating instructions
- cleaning and maintenance instructions
- Please make the instructions and additional information from the manufacturer available to the personnel at their workplace.
- Regularly check your personnel's safety consciousness and awareness of the risks, taking into account your operating instructions.
- Please ensure that the cleaning intervals are complied with, in particular cleaning after every tanning session.
- Please ensure that your personnel provide your customers with appropriate advice, in particular regarding tanning times, possible risks and the operation of the device.

1.5.3 Scope of delivery

Information regarding the scope of delivery is contained in the 'Description' chapter on page 29.

1.5.4 Transport, assembly and setup

The device is delivered by a specialist company and assembled and set up by the manufacturer's own service personnel or by an authorized service company.



As an operator you are responsible for complying with the on-site ventilation and electrical requirements at the setup location, see page 15.

Assembly

DANGER!



Personal danger due to electric shock or burns!

- The assembly and electrical connection must comply with the national regulations.
- The on-site electrical installation must be fitted with an easily accessible all-pole isolating device (master switch), complying with overvoltage category III. This means that each pole must have a contact opening width complying with the conditions of overvoltage category III for full isolation.
- If the connection is established via a plug-in connection then the connection system according to EN 60309 must be utilized.
- Assembly, installation, upgrading or repair of the device may only be carried out by specially trained and authorized personnel.

Information regarding the disassembly and assembly of the device is available in the separate assembly instructions. These assembly instructions are intended solely for use by the manufacturer's service personnel or by qualified specialists authorized by the manufacturer.

Ventilation

WARNING!



Risk of overheating due to air flow problems!

Operating faults possible.

- Do not change, obstruct or block the air inflow and outflow area to the unit or make any unauthorized changes to the unit. The manufacturer shall bear no liability for damage or injuries resulting from such actions.
- Observe the ventilation system data.
- Do not set up and operate the device on the transport pallet!

You can obtain data regarding the air supply and ventilation from the customer service department (see page 2).



Setup location

WARNING!



Salty air! Contaminated air!

Device damage due to corrosion of the housing and electrical components.

- Do not set up the unit at a swimming pool.
- Do not operate the device in locations with aggressive environmental conditions (e.g. air containing chlorine).

Damage to unit possible!

Where there are great differences in temperature between the transport route and the installation site the unit may not be put into operation immediately after being set up.

- Wait at least 2 hours before connecting the unit to the power supply.

Risk of overheating due to air flow problems!

Operating faults possible.

- Do not change, obstruct or block the air inflow and outflow area to the unit or make any unauthorized changes to the unit. The manufacturer shall bear no liability for damage or injuries resulting from such actions.
- Observe the ventilation system data.
- Do not set up and operate the device on the transport pallet!

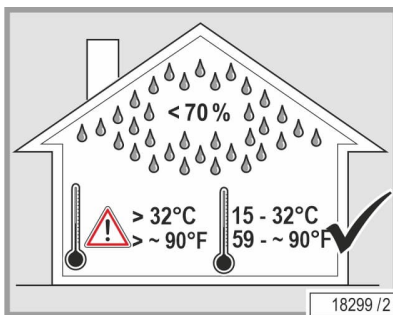

Environmental conditions

Possible damage to the unit!

The unit is not to be used outdoors.

Keep the unit away from open flames or sources of ignition.

- Optimum ambient temperature: Between +15°C and +32°C
- Storage temperature: Between -15 °C and +60 °C

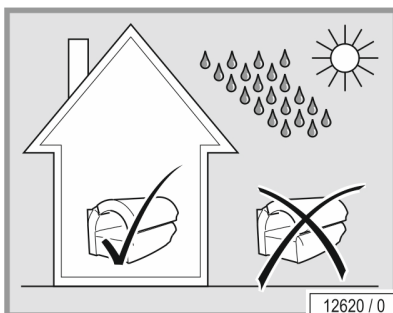

Adaptation of the unit is required for operating altitudes greater than 2000 m above sea level in order to guarantee trouble-free operation.

The device is not suitable for operation in mobile facilities (ships, buses, trains). Adaptation of the unit is required in order to guarantee trouble-free operation when used in mobile facilities.

Please contact the Customer service department without fail before putting the unit into operation - see page 2.

1.5.5 Commissioning

 DANGER!



Damaged mains power cable!

Danger to persons through electric shock or burns.

- Only the manufacturer or specialist companies are permitted to replace the mains power cable.



Initial commissioning will be undertaken by the manufacturer's own service personnel or by an authorized service company. The device will be handed over ready for use.

If the device has not been used for a longer period of time, then it must first be inspected by our customer service department or by another authorized company before being put back into operation again.

The device is operated with an external time-control unit.

A time control unit must be attached so that the device automatically switches off at the latest after <110 % of the selected running time even if the controller fails. The device running time must be secured with a timer control that complies with the standard EN 60335-2-27).

Dependent on the local power supply company, the devices can transmit interference to the power system of the building that impair the audio-frequency remote control system used by the power supply company. This can, for example, interfere with the function of night-storage heaters.

If faults occur due to the operation of the devices, then the operator is responsible for the installation of an audio frequency blocking device in the building electrical installation. Please contact your electrician. The electrician is familiar with the technical connection conditions of your local utility company so that the audio-frequency blocking device can be matched to the power system of your power supply company.

The unit can be operated temporarily or continuously with a stand-alone or non-mains-synchronous power supply (e.g. microgrid or back-up system). However, you must contact the customer service department before putting the unit into operation in this way – see page 2.

1.5.6 Operation and maintenance

Error-free operation, maintenance and service are required in order to ensure that the health and safety of the users is not endangered during operation and to ensure that the device is in a fault-free operating condition.

Please observe the information and recommendations provided in these operating instructions. Please ensure that the intervals for the inspection, maintenance and service are complied with. Please ensure that the lamps are replaced after the specified usage time.

Unauthorized modifications and changes to the device and its control unit are prohibited. Failure to comply with this invalidates the operating licence!



To avoid hazards, the device must not be used if the mains power cable is damaged. A damaged mains power cable must be replaced by the manufacturer or their customer services, or by trained and qualified specialist personnel.



NOTE:

If a fire is suspected, immediately disconnect the power supply as long as this is safely possible. Continue to observe all regulations required by law, public authorities and employer's liability insurance associations, which remain unaffected by the aforementioned instructions.

1.5.7 Decommissioning

The device must be disconnected from the power supply in order to temporarily or permanently decommission it.

You must abide by the legal disposal requirements when permanently decommissioning the device.

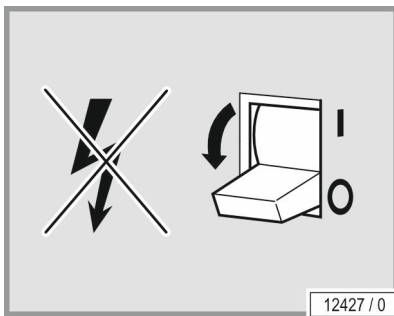

1.5.8 Storage

Store the devices in a dry location with a stable temperature. Once the device has cooled off, pack it in plastic wrapping to protect it against scratches.

- Storage temperature: Between -15 °C and +60 °C

CAUTION!



Inflammable refrigerant in the air conditioning system!

Leaking refrigerant can lead to fires or explosions.

- Avoid sources of ignition! Fire, naked flames and smoking are prohibited.
- Only ever store in rooms without permanent sources of ignition, e.g. naked flames, functioning gas appliances or electric heaters.

1.5.9 Disposal

Environmental regulations – disposal of lamps and batteries

Lamps contain fluorescent materials and other waste containing mercury. Batteries contain heavy metal compounds.

Within the European Union the national implementation of the Waste Framework Directive 2018/851/EG applies. According to the national waste disposal laws and in accordance with the municipal waste regulations, proof must be provided of the proper disposal of lamps and batteries.

Your local sales agency will be happy to assist you with the disposal of lamps and batteries:

- Inform your local agency of the number of lamps and batteries by telephone or in writing.

The agency will then provide you with the name of a free delivery point for your lamps or will take care, in conjunction with a disposal company, of the collection and proper disposal of the lamps. This service is available for a fee. Outside Germany, the respective national legislation applies. Please contact your local sales agency.

Packaging

All packaging consists of 100 % recyclable materials. Packaging brought into circulation by the JK Corporate Group that is no longer required can be returned to the JK Corporate Group. Your partner agency or dealer will be happy to advise.

Disposal of old units

The unit has been manufactured using recyclable materials. The JK Corporate Group will provide you with information on the content or potential hazards of the materials used.

The manufacturer is obliged to take back and dispose of certain electrical and electronic components in accordance with the 2012/19/EC Directive.

The components and units are labelled with the following symbol:

The unit will, if requested, be properly disposed of by the JK Corporate Group. This service is available free of charge. Your partner agency or dealer will be happy to advise.

Registration numbers

Companies within the JK Corporate Group are registered as manufacturers in Germany and accept all obligations in respect of the German Electrical and Electronic Equipment Act.

Registry number JK-International GmbH, Division JK-Licht GmbH (lamps):

WEEE-DE 61515020

Registry number JK-Products GmbH (Devices):

WEEE-DE 62655951

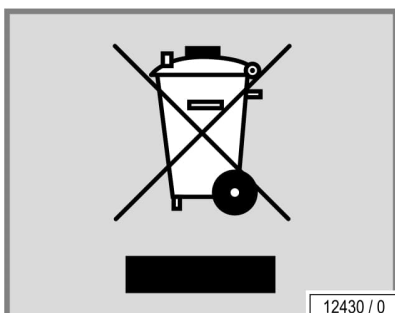
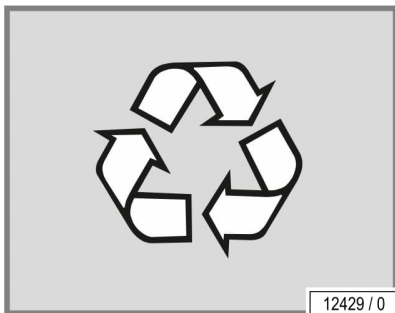



1.5.10 Directives

See the included EC Declaration of Conformity.

1.5.11 Export

We emphasize that these units are only intended for the European market and must not be exported to or operated in other countries e.g. the USA or Canada! The manufacturer does not accept any liability in the event of non-observance! We explicitly emphasize that non-compliance may result in high liability risks for the exporter and/or the operator.

1.5.12 Own music

If a smartphone is used privately during the application, this does not constitute a public performance within the meaning of the Copyright Act, so that the studio operator is not obliged to report or pay fees to the awarding body for commercial performance rights.

For the public use of music files, the same regulations apply as for other sources of music: As the owner/operator of the studio, you are only permitted to play original audio files on your premises and/or in the "MP3 music module" included in JK International GmbH units if you have acquired the performance rights required for this purpose. You can obtain these rights from the organisation responsible for granting commercial performance rights in your country (in Germany: GEMA/GVL).

Copyright-protected audio files and the tracks included on these sound storage media may not be converted into MP3 format and/or stored on HDDs, audio CDs, MCs, audio DVDs, etc., if the conversion/storage process uses software that invalidates or bypasses the copyright protection included on the sound or data storage media.

You must be ready at any time to prove your granting of stage rights by presentation of the appropriate stage rights certificate when requested by a representative or another controlling body of the responsible organisation.

Provided that you have complied with all the information above and acquired the rights required for using the "MP3 music module", you can also convert your original audio files into the MP3 format required for the playback device. However, only one copy (duplicate or copy converted into MP3 format) may be produced of each legally acquired audio file. The source media (original sound storage media) must be kept and may not be used simultaneously.



NOTE:

Recorded SD cards that are supplied with a JK audio system as accessories are also subject to payment for commercial use if they contain PRS for Music-liable content.

1.5.13 Technical modifications

The device has been constructed in accordance with the current state of the art and the applicable safety regulations. The illustrations and specifications in these operation instructions are subject to technical modifications which are required in order to improve the device.

Unauthorized modifications and changes to the device and its control unit are prohibited. Failure to comply with this invalidates the EC conformity!

Please use only original spare parts. Failure to comply with this invalidates the EC conformity!



1.6 Signs and stickers on the unit

Danger area warning signs and important information about components are attached to the unit. The signs shown below are examples. Ensure that the warning signs are always clearly recognisable and legible. Any missing warning signs or stickers must be replaced.

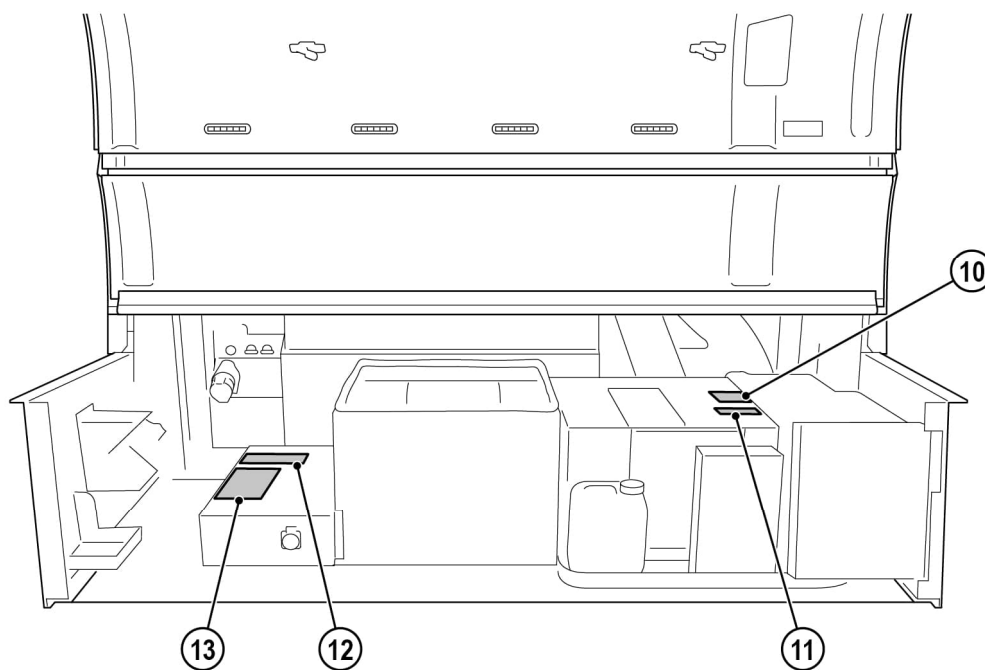
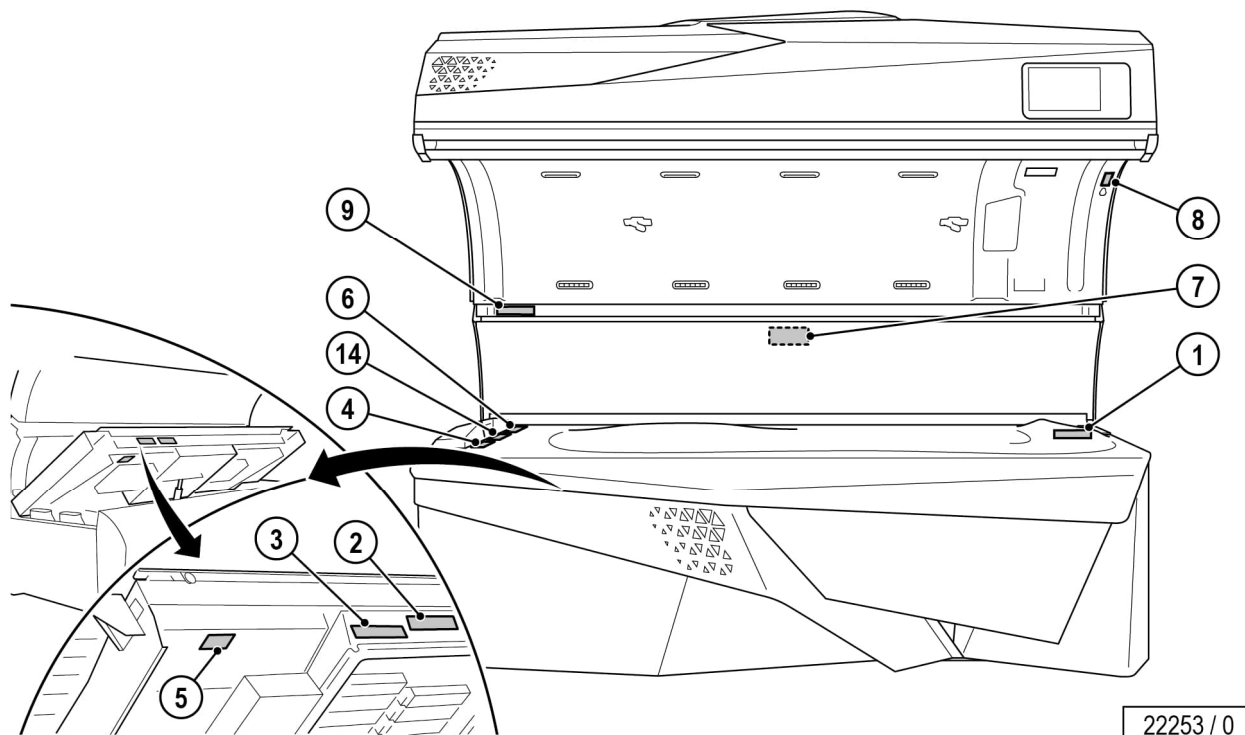

1: EU warning sticker (1012638-..)

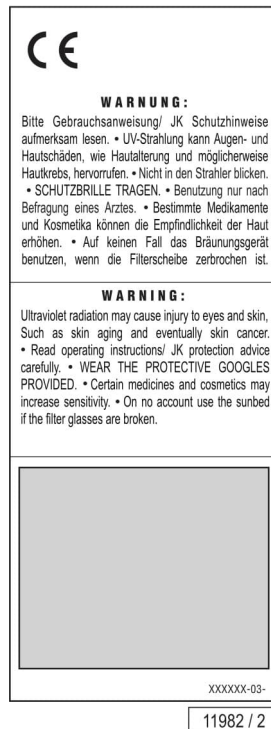

The sticker is located on the lamp cover in the base on the head end.

This sticker also includes the language form 1504231-.. (see accessories Technical Documentation).

2: 'No export USA/Canada' sticker (84829-..)

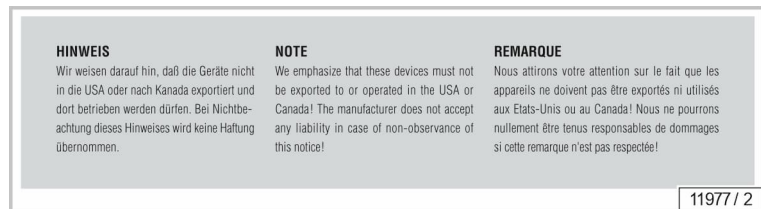

The sticker is mounted on the bottom edge at the front of the bed base.

3: 'Only use original spare parts' sticker (801026-..)

The sticker is mounted on the bottom edge at the front of the bed base.



4: Lamp set sticker

			Ergoline ESPERT 770-S DYNAMIC POWER		
	①	19x		Ergoline TREND 80-200 W ES	1504250-
	②	8x		Ergoline TREND 80-200 W ES	1504250-
	③	22x		Ergoline TREND 80-200 W ES	1504250-
	④		4x	Ergoline ULTRA 325W	150445
		3x	2x	ULTRA PERFORMANCE 802	1504284-
		2x	ULTRA PERFORMANCE 802	1504284-	
		2x	Ergoline TREND 8 W ES	1503063-	
	-	-	-	-	-
		2x	Ergoline ULTRA 180 W	1504384-	
		2x	ULTRA PERFORMANCE 802	1504284-	
		2x	ULTRA PERFORMANCE 802	1504284-	
JK-Products GmbH / GERMANY					1003066-01

12846 / 0

The precise details of the required lamps are available in the separate appendix.

5: AQUA FRESH sticker (800839-..)

The sticker is mounted on the bottom of the bed base.

6: Maintenance instruction sticker (800701-..)

ACHTUNG!
 Dieses Gerät muß regelmäßig nach Hersteller-
 vorschrift technisch gewartet bzw. Über-
 prüft werden, um jegliche Gefahr körperlicher
 Schäden vollständig auszuschließen.
 Plakettenbeschriftung = "Geräteproduktion ...
 Quartal /Jahr"

ATTENTION!
 This sunbed must be checked and serviced
 at regular intervals in accordance with the
 manufacturer's specifications in order to
 rule out entirely any risk of physical injury.
 Label wording = "Date of manufacture ...
 quarter/year"

12225 / 1

The sticker is mounted at the foot end on the inside of the canopy.

7: 'Remove lattice' sticker (842971-..)

The sticker is mounted at the top of the rear panel.

8: Emergency off sticker (1032984-..)



The sticker is mounted at the head end on the inside of the canopy.

Language form 1032985-.. pertains to this sticker (see Technical Documentation folder).

9: Type plate

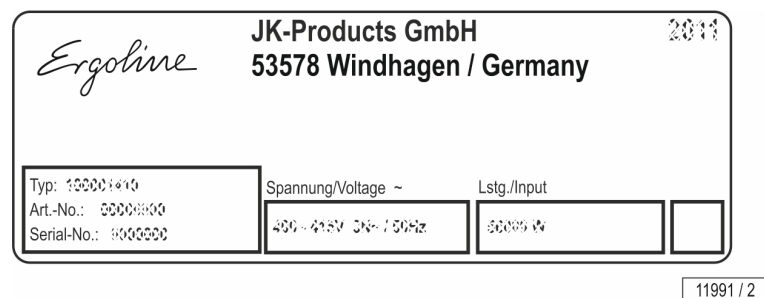

The name plate is attached to the interior side of the canopy. It contains important information for identifying the device (e. g. the serial number = Serial-No.).

Stickers 10,11,12 and 13 are mounted beneath the bed base.

10: Air conditioning sticker (1002243-..)

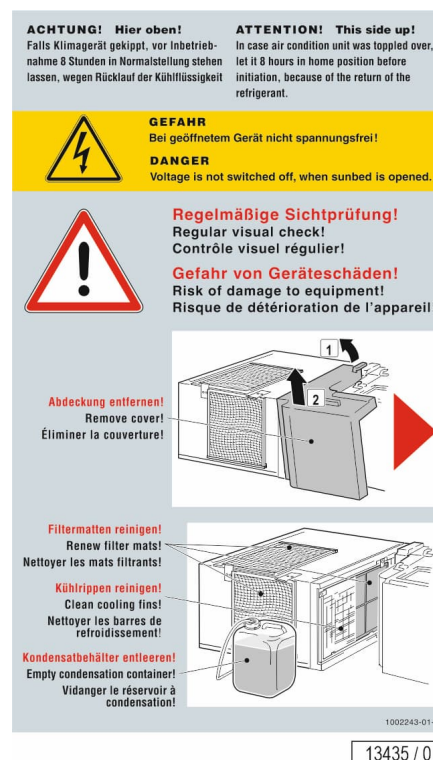

The sticker is mounted on the air conditioning.



11: Air conditioning system sticker R32 (1032302-..)

	<p>ACHTUNG! Feuergefährliches Kühlmittel im Klimagerät! Feuer, offenes Licht und Rauchen verboten!</p>	1032302-00-
	<p>ATTENTION! Flammable refrigerant in the air conditioner! Fire, naked flames and smoking prohibited!</p>	
	<p>ATTENTION ! Liquide de refroidissement inflammable dans le climatiseur ! Interdiction de faire du feu, d'allumer des lumières nues et de fumer !</p>	21748 / 0

12: Control box warning sticker (1033325-..)

	<p>GEFAHR! Bei geöffneten Gerät nicht spannungsfrei! DANGER! L'appareil n'est pas hors tension lorsqu'il est ouvert !</p>	<p>DANGER! Voltage is not switched off, when sunbed is opened! PELIGRO! El voltaje no se apaga cuando se abre la cama solar!</p>
<p>SICHERHEITSHINWEIS: Zum störungsfreien Gerätebetrieb muß der Steuerboxdeckel immer ordnungsgemäß verschlossen sein! NOTE ON SAFETY: The control box cover must always be properly closed on for fault-free device operation! CONSIGNE DE SÉCURITÉ: Le couvercle du boîtier de commande doit toujours être correctement fermé pour assurer le bon fonctionnement de l'appareil! NOTA DE SEGURIDAD: La cubierta de la caja de control siempre debe estar atornillada para evitar fallas!</p>		
	<p>ACHTUNG! ESD-empfindliche Bauteile. Vorsichtsmaßnahmen beachten! Arbeiten an den Leiterplatten nur durch geschultes Fachpersonal! CAUTION! Components sensitive to ESD. Observe precautionary measures! The PCBs may only be worked on by specially trained personnel! ATTENTION! Composants sensibles aux décharges électrostatiques. Respecter les mesures de précaution! Exécuter les travaux portants sur les circuits imprimés uniquement par un personnel spécialisé ayant reçu une formation appropriée! ¡ATENCIÓN! Componentes sensibles a ESD. Observe las medidas de precaución. Los trabajos en las placas de circuitos sólo deben ser realizados por personal especializado!</p>	
21870 / 0		

The sticker is mounted on the controller support.

13: Note! Only genuine parts (800702-..)!

<p>Hinweis !</p> <p>Verwenden Sie in diesem Gerät ausschließlich Original-JK-Ersatzteile. Bei Schäden, die nachweislich durch die Verwendung von nicht Original-Ersatzteilen entstanden sind, wird jegliche Haftung ausgeschlossen. Eigenmächtige Umbauten und Veränderungen am Gerät oder an der Steuerung sind nicht gestattet. Bei Missachtung erlischt die Betriebslaubnis! Des Weiteren erlischt unsere EU-Konformitätserklärung (CE-Kennzeichen).</p> <p>Note !</p> <p>Please use only original JK spare parts in this device. Any liability for damage or injury proven to be the result of the use of non-genuine spare parts is excluded. Unauthorized modifications and changes to the device and its control unit are prohibited. Failure to comply with this voids the operating licence! In addition, our EU Declaration of Conformity (CE certification) shall also be voided.</p> <p style="text-align: right;">JK Teile Nr.: 800702-01</p>	21311 / 0
--	-----------

The sticker is mounted on the controller support.

14: Sticker Blue LED risk group 2 (1020652-..)



The sticker is located on the lamp cover in the base on the foot end.

ESD (Electrostatic discharge) - sensitive components sticker (85662-..)

This sticker is mounted in several places in the device.



1.7 Preclusion of damage

Insofar as the customer asserts any rights related to a defect in the unit based on the legal warranty and/or guarantee, the following shall apply:

The warranty and guarantee do not cover wear parts such as low-pressure lamps (tubes) or consumables (aroma) or acrylic glass panels.

Should the product contain faults, JK-International is entitled and obligated to repair or replace the product at its own discretion. Where it is not possible to repair or replace the product, the customer may withdraw from the purchase agreement or reduce the purchase price by a suitable amount.

The warranty period is two years from delivery or from acceptance, if an acceptance process is required. This does not affect the rights of the customer under the existing warranty with regard to any claims that the customer might have in accordance with the contract of purchase.

1.8 Exclusion of liability

Regardless of the legal grounds, liability of the JK Group shall be excluded if damage can be attributed to one or more of the following causes:

- improper use of the unit;
- improper assembly, commissioning, operation and maintenance of the unit;
- operating the unit with faulty safety equipment or improperly attached or non-functional safety and protective equipment including warning signs;
- not complying with the information in the operating instructions regarding transport, storage, setup, commissioning, operation and maintenance;
- the use of untrained personnel;
- unauthorized changes to the unit or the control unit;
- inadequate monitoring of parts subject to wear;
- repairs carried out improperly;
- the use of non-original spare parts;
- emergencies and disasters resulting from the influence of foreign materials or force majeure.

2 Description



2.1 Scope of delivery

- Tanning device
- LED SHOULDER TAN with sound system including Bluetooth® and wireless charging station
- Service kit: includes Allen key and suction cup for acryl panels and filter panels
- Air conditioning system
- Connecting lead
- Protective goggles
- Mastercard NFC (studio operator)
- Technical documentation (operating instructions, error code brochures and PROFESSIONAL SETUP MANAGER PLUS and other documents)

2.1.1 Options

- REMOTE SERVICE
- Central exhaust air socket

2.2 Equipment

Device equipment varies depending on the model.

In this description, all standard and optional components/functions are taken into account which must be observed during operation and/or when performing maintenance.

The control panel also differs according to the varying equipment: Only those buttons are illuminated from behind that can be operated, i.e. the corresponding function must be included in the device's equipment.

2.3 Unit description

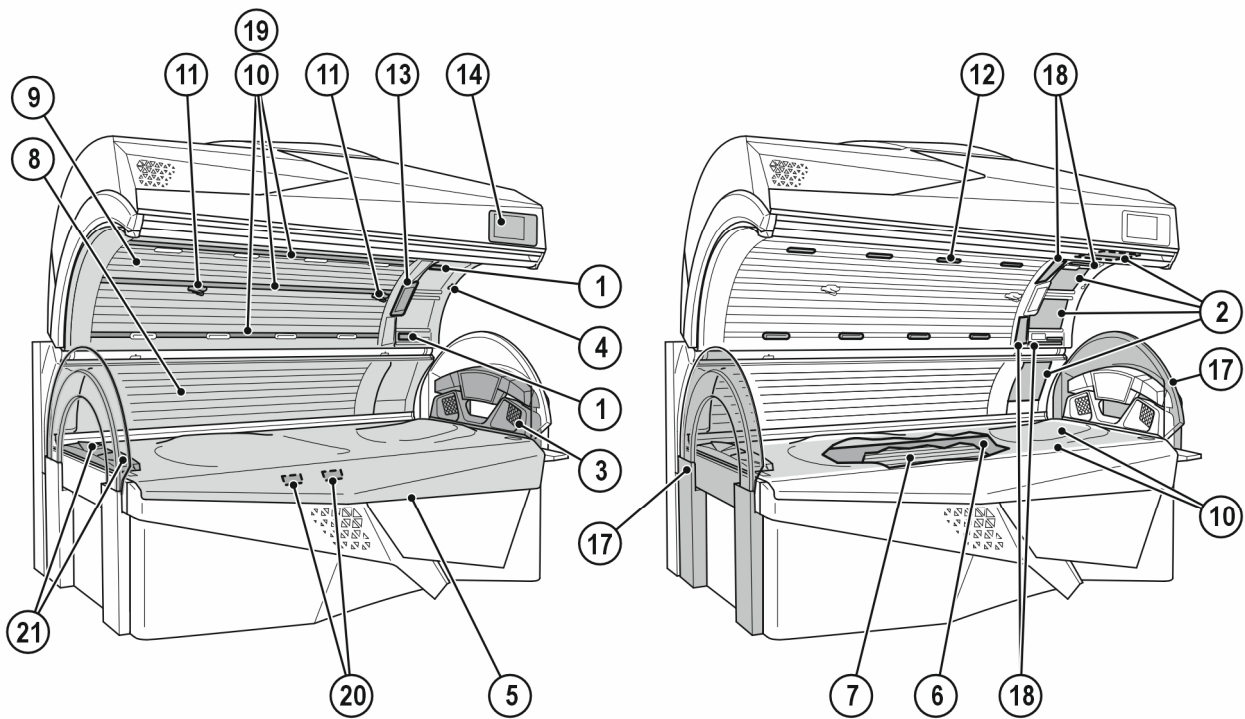

22255 / 0

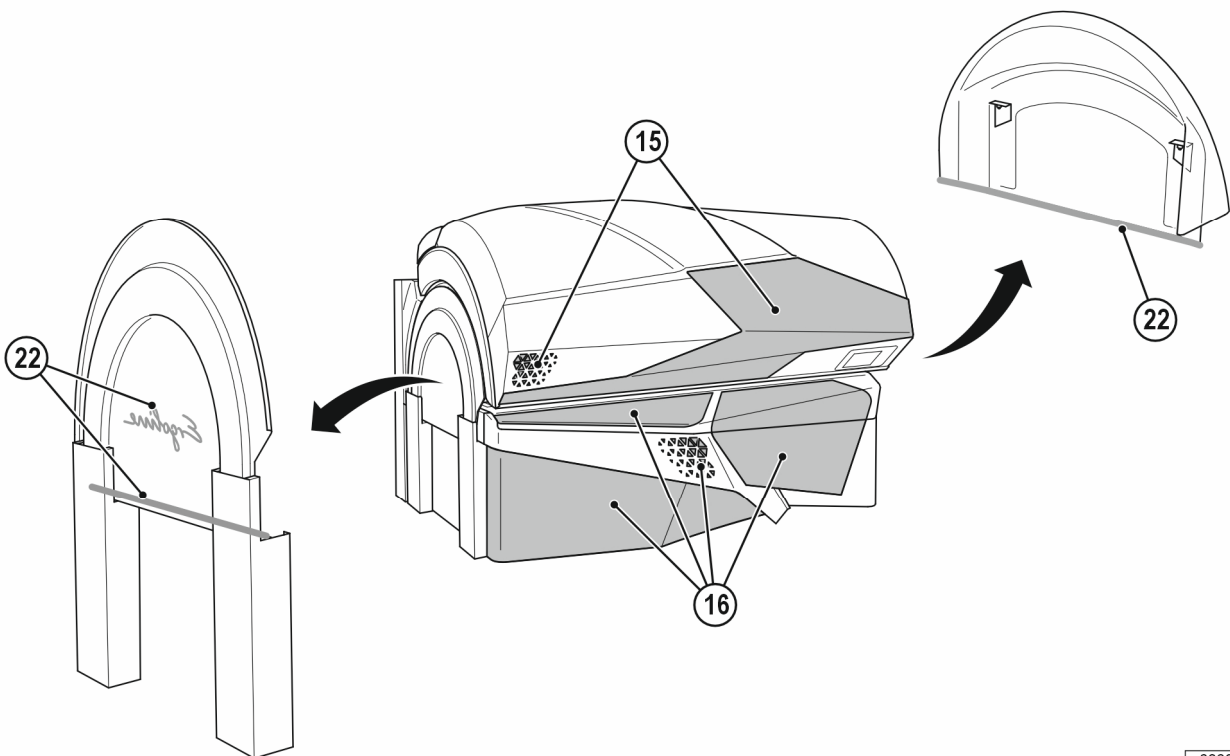

22291 / 0

1. Adjustable air nozzles – Facial cooling
2. Facial tanner (high pressure lamps + low pressure lamps)
3. LED SHOULDER TAN with sound system, including Bluetooth® and wireless charging station for smartphones
4. EMERGENCY OFF button
5. Acrylic glass panel base
6. Partition
7. Low-pressure lamps, base
8. Low-pressure lamps, side section
9. Low-pressure lamps, canopy
10. Interior lighting (LEDs)
11. Nozzles AQUA / AROMA SYSTEM
12. Body cooling air nozzles
13. INTERIOR DISPLAY (TOUCH)
14. EXTERIOR DISPLAY (TOUCH) & NFC CONNECT
15. Decorative lighting, canopy (LEDs)
16. Decorative lighting, front panel (LEDs)
17. Enclosed tanning tunnel
18. FUSION LIGHT (red & blue) face + neckline
19. FUSION LIGHT (red & blue) body
20. Service Light (only with opened bed base)
21. Body cooling air nozzles, foot end
22. Accent lighting tanning tunnel (LED)





2.4 Accessories (optional)

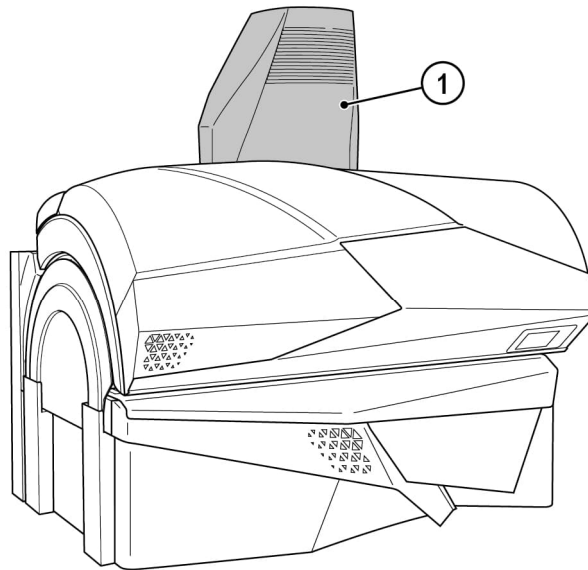

22256 / 0

1. Central exhaust air socket (optional)

2.5 Functional description

The primary technical components of a solarium are an artificial source of UV radiation and a mechanical structure with a defined active surface.

The Prestige Fusion Edge enhances the UV spectrum with red light (Beauty Light) and blue light (Activating Light).

3 Operation



3.1 User safety information

 DANGER!



UV radiation

Danger of skin and eye injuries or skin diseases!

- Please observe the safety instructions and warnings in chapter 1.

Danger of hearing damage!

Listening to music at a high volume can result in permanent hearing damage.

- Do not set the volume too high.

3.2 Tanning - but correctly!

A few things need to be noted in order to obtain maximum enjoyment from a tanning unit. Here are some answers to frequently asked questions.

Make-up on the sunbed?

A wide variety of materials is found in cosmetics. Whether these are emulsifiers, greases, or fragrances – in conjunction with UV radiation, these can cause skin allergy reactions.

For this reason, always use cosmetics that have been specially developed for use in tanning booths.

So, this to-do list is a must before using a tanning unit: Remove all make-up. This is essential. Make-up clogs the pores in the face. The UV light from a tanning unit re-opens these clogged pores so that not only does the light penetrate the skin, but also the allergenic components of the make-up.

A further negative consequence of make-up is that the appearance of the skin deteriorates irreversibly over a period of time. However good decent make-up looks - in conjunction with UV light, it causes more harm than good. Therefore: Remove all make-up before a session on your sunbed - it will be much better applied afterwards.

Showering after leaving the sunbed?

The browning is in the skin, not on it. Therefore you cannot wash it off. Treat your skin to a moisturizing cream after showering.

Are medications and the sunbed compatible?

It is known that some medicaments increase the skin's sensitivity to UV light. This probability is particularly high with antibiotics, sulphonamides, psychiatric drugs, tranquillizers, anti-diabetes treatments and diuretics. Sun creams which contain psorale or kumarin also increase skin sensitivity. If you are in any doubt, first ask your doctor - then you can enjoy the sun at no risk.



Contact lenses on the sunbed?

The answer is: Yes! Like any other tanning unit user, contact lens wearers should also wear special protective goggles which protect the eyes against UV radiation. To guarantee better protection, wearers of spectacles and contact lenses can ask their optician for exchange contact lenses with UV protection. The UV-A and UV-B filters built into exchange contact lenses will protect the cornea and the internal parts of the eye against almost 100 % of the energy in UV radiation.

This will benefit tanning unit users not only in the open air, but on the tanning unit itself. You can wear these contact lenses on the tanning unit without any restrictions. For more information, ask your optician or optometrist.

3.3 Operating overview

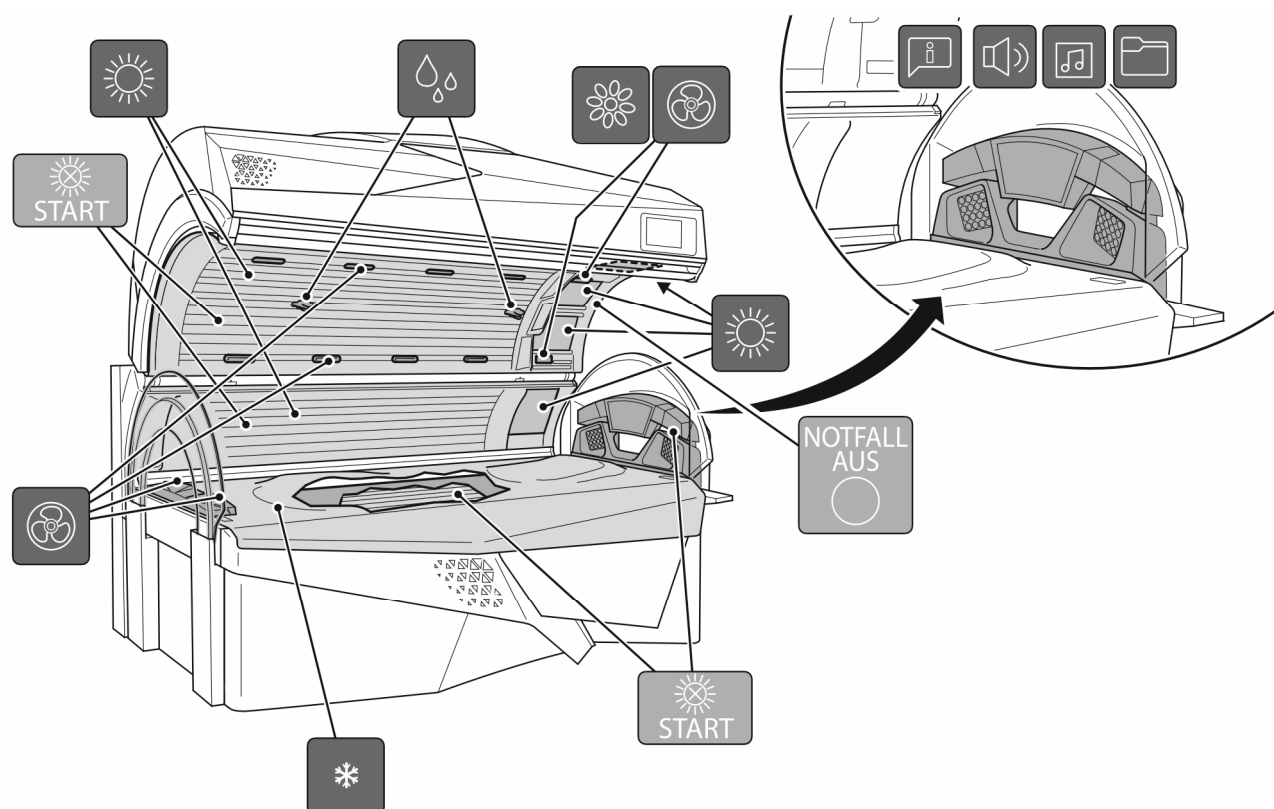

22257 / 0

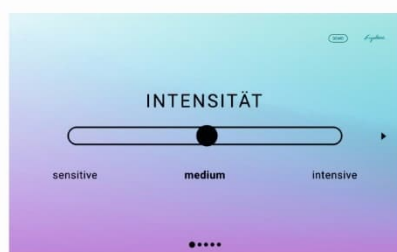

SELECTABLE TANNING PROGRAMS

Before the session begins, the desired application type must be selected. There are 3 possible selections: See chapter 3.5

NCF CONNECT

After tanning: Individual settings can be stored on an NFC medium (e.g.: NFC tag).

Before tanning: Individual settings can be transferred to the unit.



During the tanning session, functions can be activated or deactivated on the **INTERIOR DISPLAY**.

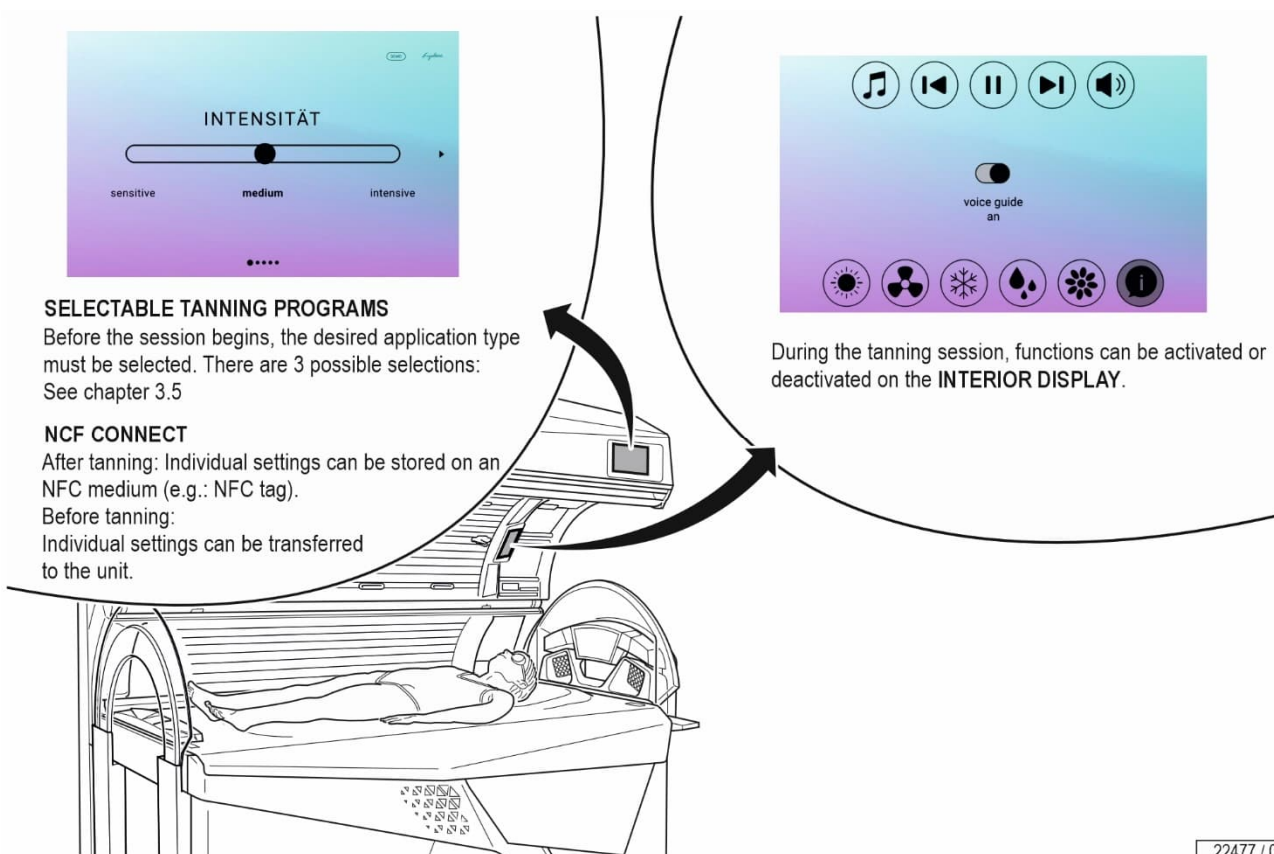

22477 / 0



3.3.1 PROFESSIONAL SETUP MANAGER PLUS

In PROFESSIONAL SETUP MANAGER PLUS, operating states can be called up and pre-settings entered.

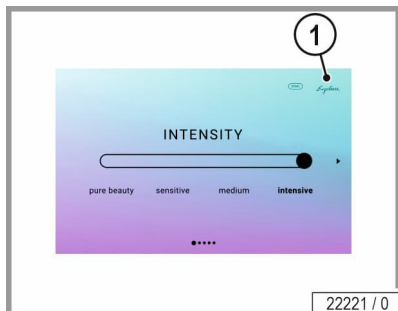

NOTE:

Pre-setting mode can only be called up when tanning is not taking place.

30 seconds after the last button was pressed, the device changes automatically into standby mode and the currently set values are saved.



NOTE:

To open the PROFESSIONAL SETUP MANAGER PLUS, press the Ergoline logo (1) for approximately 3 seconds in standby mode.

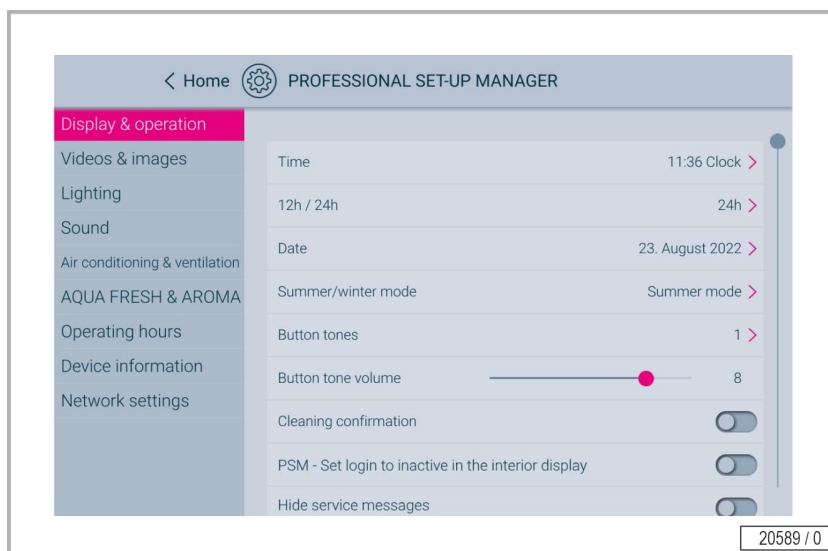

3.3.2 NFC Connect



NFC¹-Point

Data exchange via contactless near field communication.

The user settings can be saved to a special customer card so that they do not have to be set again during the next application. The stored data can be transferred to other units with similar setting options.

- Hold the customer card close to the NFC point (max. distance 3 cm).

NFC status

The data transfer is indicated by colours.



The NFC point flashes pulsating:
Ready/Standby
Data can be transferred to a data carrier.



The middle of the NFC point is green:
Settings have been successfully transferred from the data carrier.



The middle of the NFC point is blue:
Settings have been successfully transferred to the data carrier.



The middle of the NFC point is orange:

- a) Transmission error
 - Hold the card in front of the point again and wait a little longer.
- b) The data carrier is empty.
 - The settings can be saved to the data carrier after the session.

Information about the setting options can be found in the separate user manual 'PROFESSIONAL SETUP MANAGER PLUS' (order number: 1020179-..) in the technical documentation.

¹ Communication system: NFC (Near Field Communication); max. operating range: approx. 50 mm, frequency range: 13.56 Mhz



3.4 Functions

INTERIOR DISPLAY in standby



NOTICE:

If no application type is selected before the session, the user may select the desired tanning program in the INTERIOR DISPLAY.

Further information on the application types:
see chapter 3.5 on page 48.

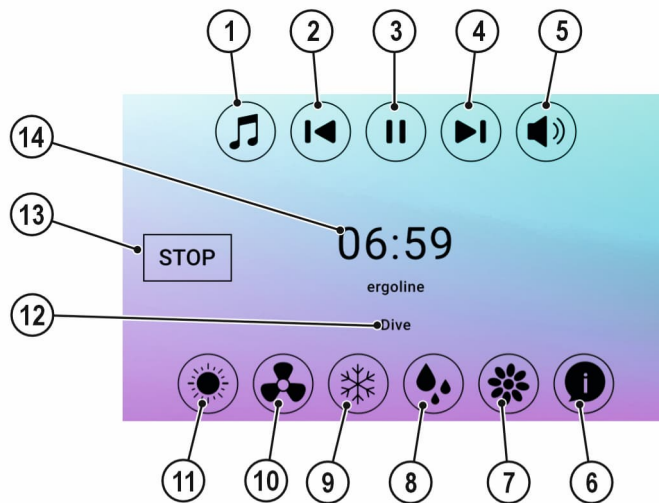

22219 / 0

1. Audio source pictogram
2. Audio back pictogram
3. Audio pause/play pictogram
4. Audio next pictogram
5. Volume pictogram
6. VOICE GUIDE pictogram
7. AROMA SYSTEM pictogram
8. AQUA SYSTEM pictogram
9. Air conditioning pictogram
10. Fan pictogram
11. Intensity selection pictogram
12. Display - Track title
13. START/STOP icon
14. Display - Tanning time

EXTERIOR DISPLAY

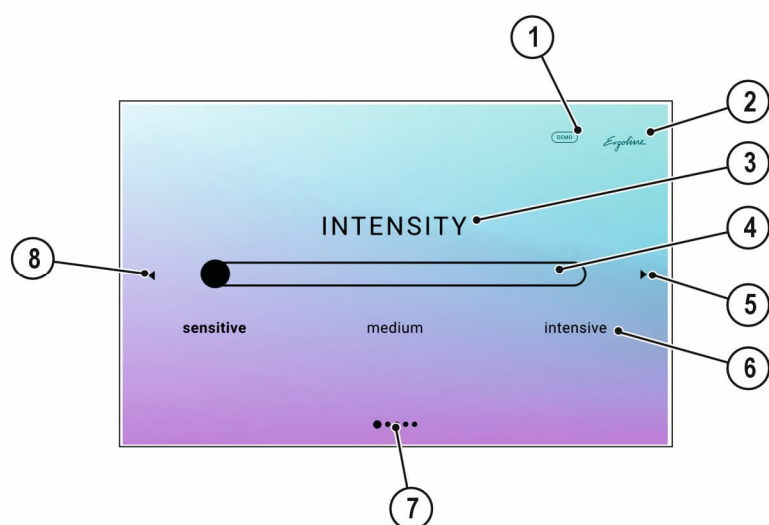

22220 / 0

1. Demo mode
2. PROFESSIONAL SETUP MANAGER PLUS (PROFESSIONAL settings)
3. Description of the selected function
4. Slider
5. Next settings
6. Possible settings
7. Settings page (page 1 of 3)
8. Last settings

**NOTE!**

When the video option is activated:

To interrupt or end the video, touch the display briefly.

More information on the Video Option can be found in the PROFESSIONAL SETUP MANAGER PLUS (order no. 1020179-..).

**NOTE!**

To activate demo mode, briefly double tap on 'DEMO' (pos. 1).

In demo mode, you can test the audio, fan and VOICE GUIDE function.

You have 30 seconds in which to select the function.



3.4.1 EXTERIOR DISPLAY

You can already configure the most important settings using the PROFESSIONAL SETUP MANAGER PLUS order no. 1020179-..).

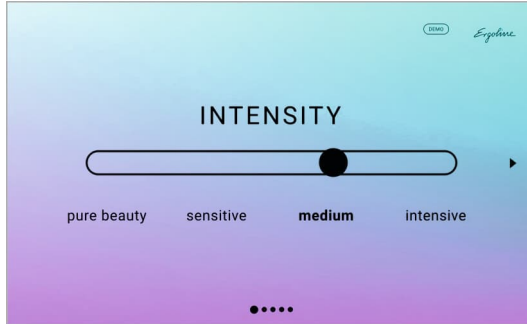

Pictogram selection / key sequence	Description/ Display	Information
	Briefly press the Ergoline logo PROFESSIONAL SETUP MANAGER PLUS opens	For the operator only.

EXTERIOR DISPLAY in the Standby

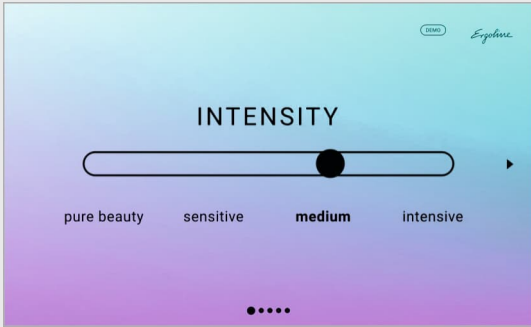
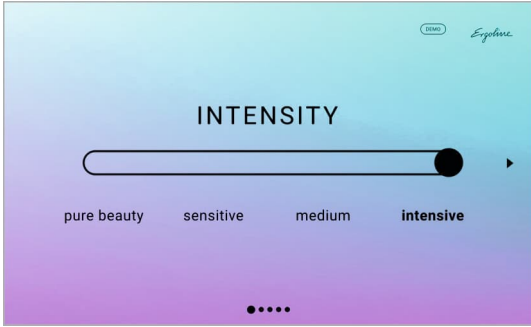
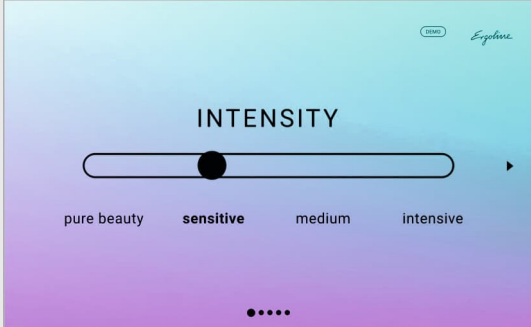
	Select 'Intensities' Move the slider or press directly on the program you want. Select 'medium'	Activate by touching.
	Select 'intensive'	Activate by touching.
	Select 'sensitive'	Activate by touching.

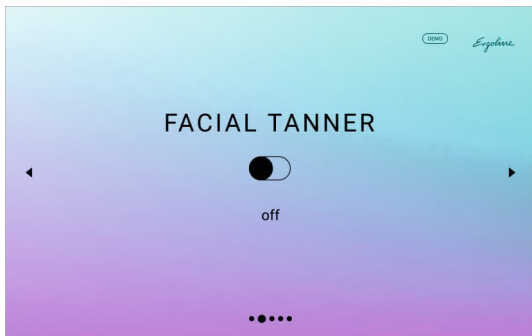
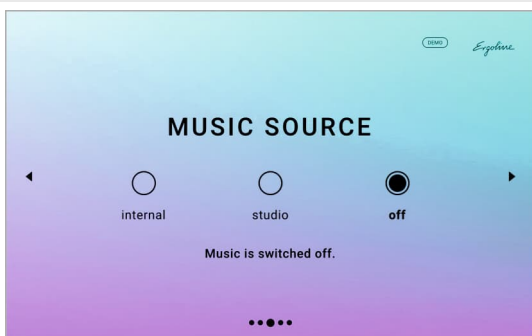
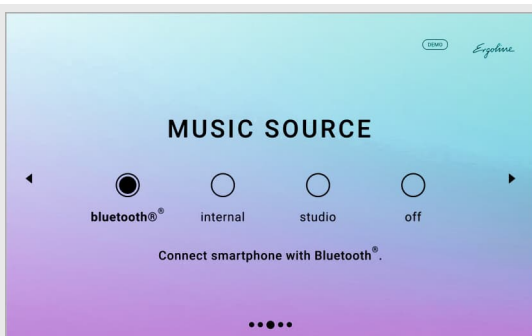
Pictogram selection / key sequence	Description/ Display	Information
	<p>Facial tanner activated</p>	<p>The function can be turned on or off by moving the slider.</p>
	<p>Bluetooth® = smartphone connection intern = internal music studio = studio channels off = music off</p>	<p>Activate by touching.</p>
	<p>Display without studio channels</p>	<p>Activate by touching.</p>
	<p>Connection to the user's smartphone.</p>	<p>Activate by touching.</p>
	<p>VOICE GUIDE activated AROMA deactivated</p>	<p>The function can be turned on or off by moving the slider.</p>



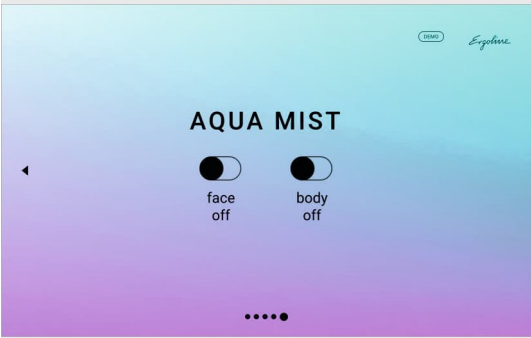

Pictogram selection / key sequence	Description/ Display	Information
	<p>AQUA FRESH body deactivated</p> <p>AQUA FRESH face deactivated</p>	<p>The function can be turned on or off by moving the slider.</p>

3.4.2 INTERIOR DISPLAY

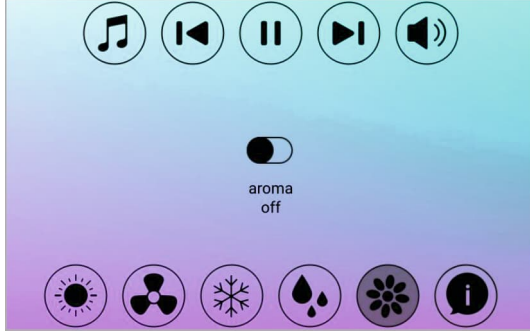
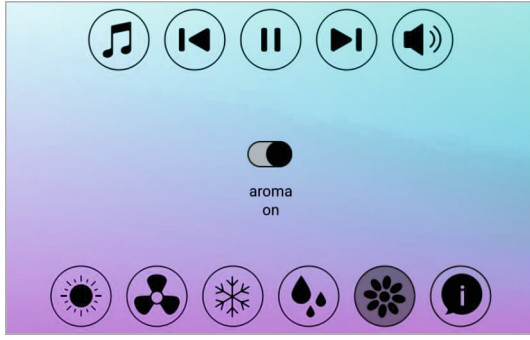
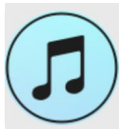
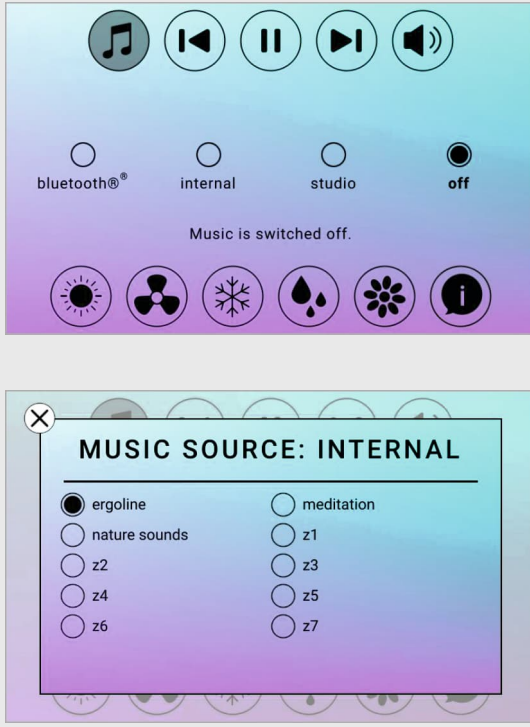
Pictogram selection/ key sequence	Description/Display	Information
INTERIOR DISPLAY during tanning		
	<p>AROMA</p>  	<p>AROMA on / off</p>
	<p>Audio source selection</p> 	<p>Bluetooth® Internal music selection Studio channel selection Audio sources 'off'</p> <p>Audio sources 'internal'</p>



Pictogram selection/ key sequence	Description/Display	Information
--------------------------------------	---------------------	-------------

	<p>Fans (face, body and foot fans)</p>	<p>The fans can be set separately for the face, body and feet. If the user does not change anything, the fan settings are automatically adapted to the temperature.</p>
		<p>Adjust face fan: Levels 0–9</p>
		<p>Adjust body fan: Levels 0–9</p>
		<p>Adjust feet fan: Levels 0–9</p>

	<p>VOICE GUIDE VOICE GUIDE on / off</p>	<p>The VOICE GUIDE guides the user through the entire operating process. This function can be switched on and off at any time</p>
--	---	---

	<p>Intensity</p>	<p>Regulate UV intensity in the facial area, levels 0-3</p> <p>Regulate UV intensity in the body area, levels 0-3</p> <p>Regulate FUSION Light, levels 0-5 FUSION Light uses the synergy of red and blue light.</p>
--	------------------	---

Pictogram selection/ key sequence	Description/Display	Information
--------------------------------------	---------------------	-------------



Volume

Levels 0 - 14

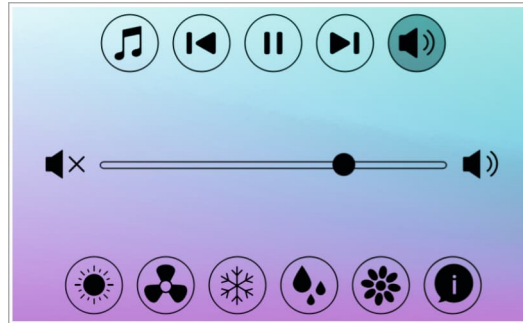

AQUA system

AQUA FRESH for body and face on/off

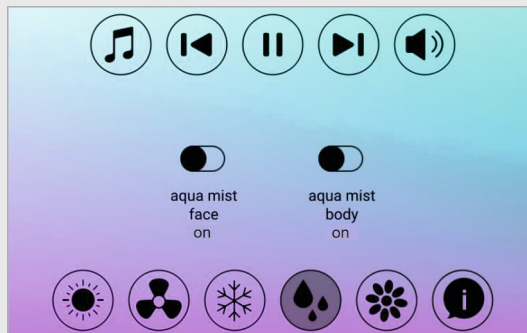
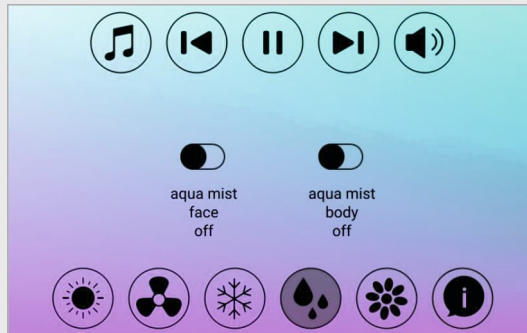

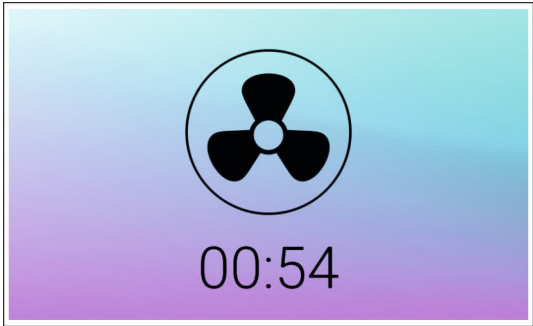
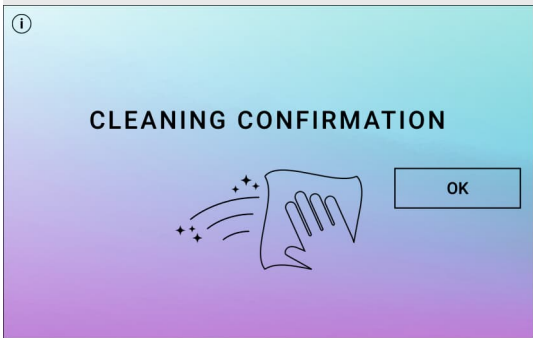
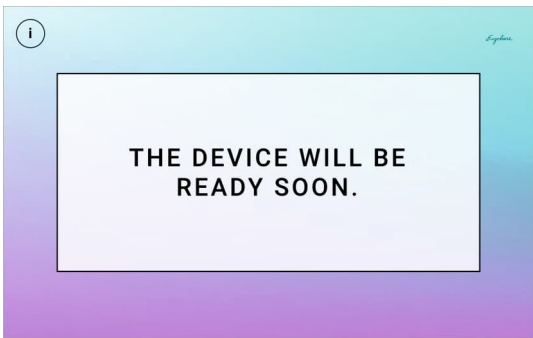
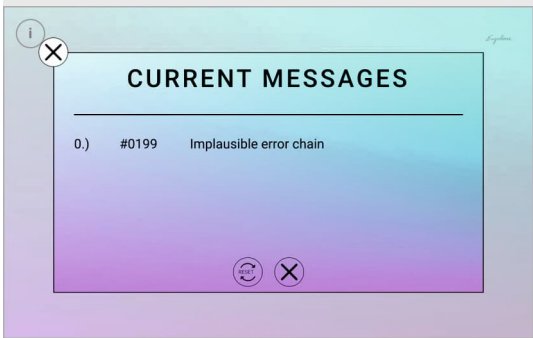

Pictogram selection/ key sequence	Description/Display	Information
	<p>Air conditioning</p>	<p>Air conditioning on/off</p>
	<p>EMERGENCY OFF</p>	<p>When the EMERGENCY OFF button is pressed, the entire unit apart from the INTERIOR DISPLAY switches off. In this state, a display appears to show that the EMERGENCY OFF button has been operated.</p> <p>The edges of the EMERGENCY OFF button also flash red at the same time. The displays appear in an alternating pattern.</p> <p>The tanning time will keep running. The VOICE GUIDE provides voice assistance.</p> <p>After being blocked for 2 seconds, the EMERGENCY OFF can be reversed again. The unit restarts in tanning mode.</p>

Pictogram selection / key sequence	Description/ Display	Information
EXTERIOR DISPLAY and INTERIOR DISPLAY after the tanning session		
	<p>AFTER THE TANNING SESSION: Fan run-on</p>	
	<p>Press 'OK' to return to the start page.</p>	<p>When the cleaning mode is activated in PROFESSIONAL SETUP MANAGER PLUS and the run-on time of the device fan has finished, cleaning must be confirmed after every tanning session by pressing the START/STOP button.</p>
	<p>Error message</p>	
	<p>Current error message</p>	



3.5 Selection of the application type (SELECTABLE TANNING PROGRAMS)



Before the session begins, the desired application type must be selected.

- INTENSIVE: 100% power of UV- and SMART SUN lamps and facial tanner
- MEDIUM: approx. 85% power of UV low pressure lamps and SMART SUN lamps, facial tanners level 2
- SENSITIVE: approx. 70% power of UV low pressure lamps and SMART SUN lamps, facial tanners level 1
- PURE BEAUTY: UV-free program

– Press the button for the desired type of application.



NOTE:

In each program, the FUSION LIGHT LED start with 100% performance. During the tanning session, the intensity of the facial tanner and the FUSION LIGHT LED can be changed at any time, or switched off completely. If no selection of the application type is carried out, the device starts up with the application type "INTENSIVE"

3.6 Start

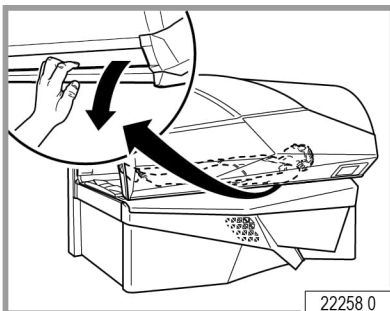

- Closing the canopy.
- Press the START/STOP button.

Upon starting the following functions are switched on:

- Lamps and LEDs
- Facial tanner
- Air conditioning system
- Body cooling
- Ventilation
- Audio system
- VOICE GUIDE

3.7 Coupling with Bluetooth® devices



DANGER!



Danger of hearing damage!

Listening to music at a high volume can result in permanent hearing damage.

- Do not set the volume too high.

Users can pair their personal smartphone with the audio system. The devices must be paired before the tanning session starts.

The solarium and the user's personal smartphone can only be paired via Bluetooth®¹Connect. When using Bluetooth® Connect, the user can transfer their favourite music into the solarium wirelessly from their smartphone. Operation can be performed conveniently via the INTERIOR DISPLAY during the tanning session.



NOTE:

- Ergoline cannot guarantee full compatibility with all Bluetooth® devices.
- Before coupling a device with this system, read the user manual to find out more about the Bluetooth® compatibility.
- Make sure that the Bluetooth® function is activated on your device and that the device is visible for all other Bluetooth® devices.

Pairing with a Bluetooth® player

Activate the Bluetooth® function and search for Bluetooth® devices.

Activate the Bluetooth® function on the iPhone®:

iPhone®:

Settings → General → Bluetooth® → ON (search for units is started.)

Activate the Bluetooth® function on the Android® smartphone:

Android® smartphone:

Press the Bluetooth® symbol → SCAN (search for units is started.)

¹ Communication system: Bluetooth® standard version 3.0, Version 2.1 and EDR; max. operating range: approx. 10 m; frequency range: 2.4 GHz range (2.4000 GHz - 2.4835 GHz); compatible Bluetooth profiles: A2DP, AVRCP; simultaneously supported devices (pairing): one device



NOTE:

The tanning device can store a maximum of ten coupled Bluetooth® devices. In the event of recoupling the tanning device must first be deleted from the Bluetooth® device. The activation process must then be repeated.

Activate Bluetooth® Connect in PROFESSIONAL SETUP MANAGER PLUS

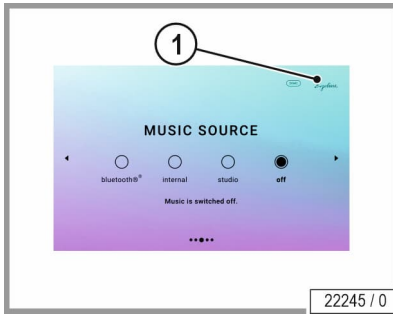

- Press the Ergoline logo (pos. 1) briefly to access PROFESSIONAL SETUP MANAGER PLUS.

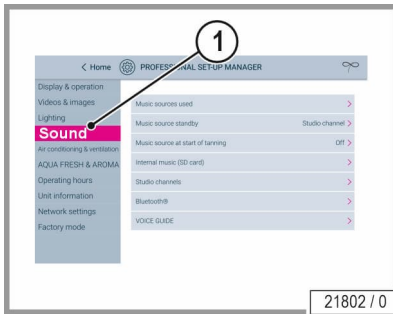

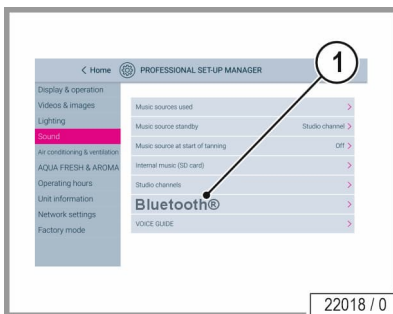

Press 'Sound' (1) in the user profile.

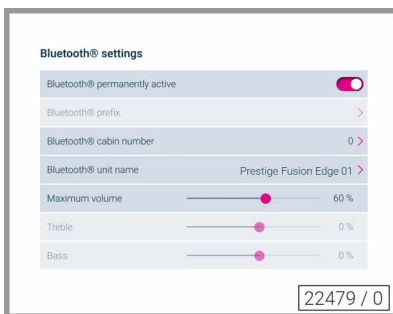

Select 'Bluetooth®' (1)



- Move the slider to activate permanently the function  or deactivate it .

Successful Bluetooth® connection in the INTERIOR DISPLAY

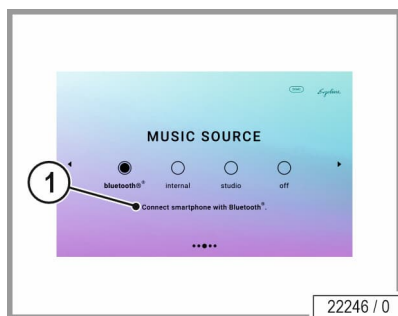

- Status display (1) when the units have been successfully paired.

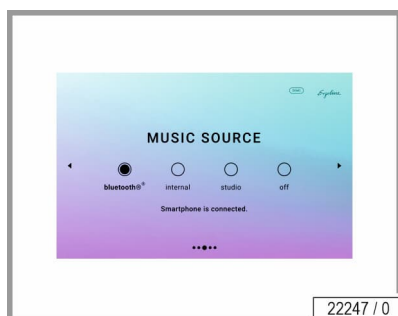

Audio sources: Bluetooth® selection in the INTERIOR DISPLAY.



3.8 Listening to music

! DANGER!



Danger of hearing damage!
 Listening to music at a high volume can result in permanent hearing damage.

- Do not set the volume too high.

! CAUTION!



Possible heat damage to the smartphone.

- Do not place the smartphone directly in the area of radiation.

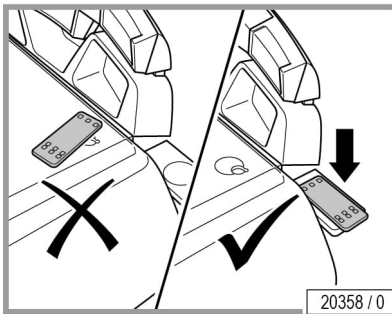

3.9 Smartphone Wireless Charging

Use this technology to charge your smartphone wirelessly. Simply place your Qi-compatible smartphone in the centre of the wireless charging station with the display facing upwards; it will start charging automatically. Straighten up the smartphone slightly if necessary until the charging function is activated.



NOTE:
 Do not place any magnetic strips, chip cards (in passports, on credit cards, etc.) or metal objects onto the charging station. Some smartphone cases can impair the charging process.

4 Cleaning and maintenance



4.1 Safety instructions when undertaking cleaning or maintenance work

 **DANGER!**



Electricity throughout entire device!
Personnel danger due to electric shock or electric burns.

- Before beginning work, disconnect all of the power connections from mains voltage.
- Secure all of the disconnected connections against accidental reactivation.
- Check that the device is disconnected from mains voltage.
- All of the work and electrical connections must comply with the national regulations of the country in which the device is being operated (e.g. the VDE regulations in Germany) and must be undertaken by appropriately trained specialists.

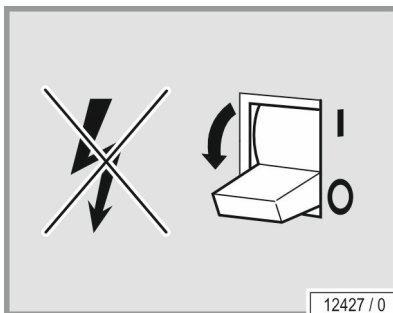

12427 / 0

If work is to be performed on the devices, they must be deenergized. That means that all live cables must be switched off.

Switching off the unit alone is insufficient, as certain points may remain energized. Therefore, switch off fuses before performing any work and – if possible – remove them.

Accidental reactivation can result in serious accidents. Immediately after deenergizing, secure all switches or fuses used for deenergizing against being switched on again.

- Lock the fuse box with a padlock.

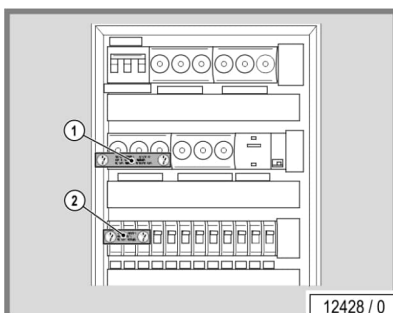

12428 / 0

In case of circuit breakers which cannot be unscrewed, a strip of adhesive tape may be applied over the actuation lever with the wording 'Do not switch, danger!' (1 + 2).

A prohibition sign with the text:

'Work in progress!'

'Place:

'Sign may only be removed by:

must always be securely mounted immediately.



4.2 Faults

Error codes are output to the display to simplify troubleshooting:

- If a fault occurs, the error code appears in the display.
- If several faults occur, the fault messages are displayed alternately.
- The error is acknowledged by pressing the START/STOP-button.
- If the error cannot be cleared, inform Customer Service - see page 2.

More detailed information regarding the error description and solutions can be found in 'Error Codes', (Order No. 1028225-..).

4.3 Cleaning

 DANGER!



Infections can be spread by skin contact!

All objects/device parts that could come into contact with the user during tanning must be disinfected after every tanning session:

- Acrylic glass panel
- Handles and control panel
- Protective goggles
- Adjustable air nozzles

We recommend a suitable rapid surface disinfectant as a cleaning agent for rapid and thorough disinfection.



NOTE:

- To ensure thorough disinfection, always adhere to the contact time specified for the disinfectant. Follow the manufacturer's instructions for use.
- After the prescribed contact time, remove any remaining residues of the cleaning/disinfecting agents.
- Use a soft, clean single-use paper towel for this purpose.
- Carry out a visual inspection. Repeat the cleaning procedure if you find dirty areas or residues of the cleaning/disinfecting agent.
- Carry out a further visual inspection.

4.3.1 Cleaning the surfaces

Acrylic glass surfaces



CAUTION!



Do not rub dry – danger of scratching!

Failure to observe this will invalidate all guarantee claims.

- Only use a rapid surface disinfectant for acrylic glass panels for fast, hygienic proper cleaning of acrylic glass surfaces.
- Do not use disinfectants or solvents (e.g. Lysoform, ethyl alcohol, or other fluids containing alcohol).

Acrylic glass panels rendered unusable due to contamination!

- Remove fingerprints, cleaning residues and other soiling carefully.

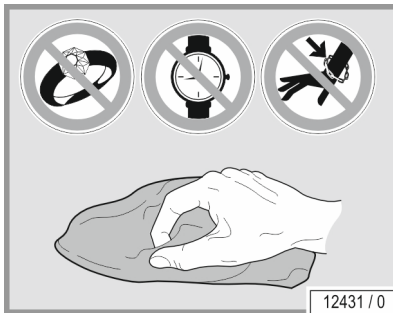

Plastic surfaces

To clean the painted and unpainted plastic surfaces, it is best to simply use warm water and a leather cloth. Never use alcohol-based aggressive cleaning agents or essential oils. These cause damage that is not covered by warranty claims.

During cleaning a slight discolouration of the leather cloth by the rubber seals must be expected for production-related reasons.

Prevent damage to the acrylic glass and plastic surfaces.

- Remove rings, watches, bracelets etc. before starting cleaning work.

4.3.2 Filter panels and lamps

- Low pressure lamps and filter panels can be cleaned with a damp cloth and without additional cleaning agents where necessary.
- High pressure lamps can be cleaned with ethyl alcohol where necessary.

4.4 Cleaning plan

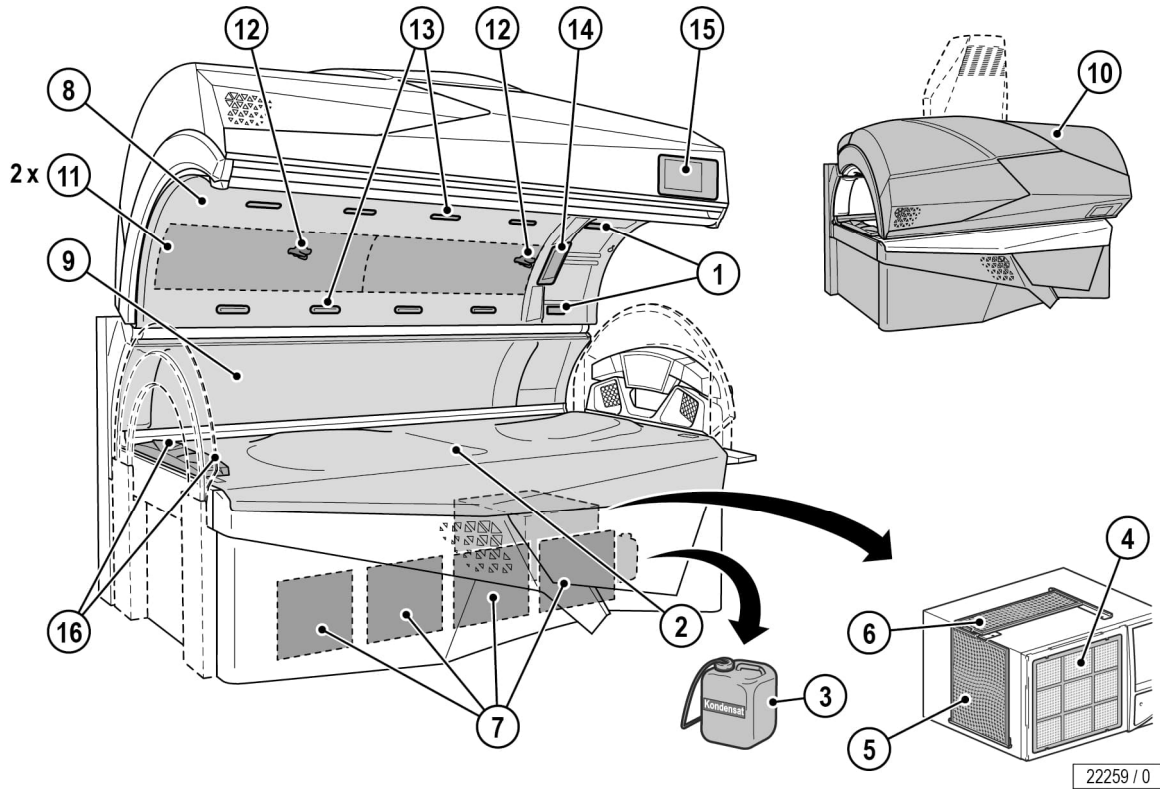

22259 / 0

Component	Interval	Activity	See page
	After each tanning session		
	When necessary		
	50 h		
1 Adjustable air nozzles/ AROMA	X	Clean and disinfect	54
2 Acrylic glass panel	X	Clean and disinfect	55
3 Condensation tank	X	Empty	78
4 Filter mat	X	Clean	78
5, 6 Filter	X	Remove and clean filter	78
7 Filter	X	Remove and clean filter	76
8, 9, 10 Surfaces	X	Clean	55
11 Filter mats	X	X	77
12 nozzles AQUA / AROMA SYSTEM	X	Clean	54
13 Body cooling air nozzles	X	Clean	54
14 INTERIOR DISPLAY	X	Clean and disinfect	54
15 EXTERIOR DISPLAY	X	Clean and disinfect	54
16 Body cooling air nozzles, feet end	X	Clean	54
Protective goggles	X	Clean and disinfect	54

**NOTE:**

When the cleaning mode is activated in PROFESSIONAL SETUP MANAGER PLUS and the run-time of the device fan has finished, cleaning must be confirmed after every tanning session by pressing the START/STOP button.



4.5 Maintenance

Maintenance and care play a major role in deciding whether the device meets the requirements placed on it in a satisfactory manner. Compliance with the specified maintenance intervals and the careful conducting of the maintenance and care work are therefore absolutely necessary.

The current operating hours of maintenance parts can be called up in service mode (see 'PROFESSIONAL SETUP MANAGER PLUS'), order no. 1020179-..

We point out that the device must be subjected to regular inspections by our customer service or an approved specialized company every 12 months (from commissioning) to maintain its proper condition!

Inspections and maintenance work that has been carried out must be entered in the equipment, operating and maintenance booklet (order no. 1019967-..).

4.5.1 Acrylic glass

WARNING!



Cosmetics may cause cracks to form on the surface! Over the long-term cosmetics or sunscreens cause damage (e.g. crack formation on the surface).

- Ensure that cosmetics and sunscreens are removed before tanning.

The acrylic panels are made of acrylic glass that is specially developed for this field of application. The acrylics used are characterised by a particularly high UV permeability and resistance, as well as an easy-care, hygienic surface that is agreeable to the skin.

The acrylic glass panels are formed to device-specific shapes in a technically complex production process. Despite state-of-the-art production know-how, the presence of minor spots, air bubbles or streaks in the acrylic panels is unavoidable. In addition, hairline cracks can occur on the acrylic glass panel during operation.

These occurrences are material-related and are unavoidable in processing. However, they have no significant effect on use and are therefore not accepted as defects.

Over the course of time the acrylic glass panels becomes more translucent as a result of usage and must be replaced by customer-service personnel on a regular basis.



4.6 REMOTE SERVICE (optional)

Being the studio operator, you have the possibility to service your Prestige Fusion Edge via REMOTE SERVICE. You can call up device information, e.g. operating hours and conduct a device configuration via REMOTE SERVICE. In case of service, the technical services can carry out a remote diagnosis online via REMOTE SERVICE.



NOTE:

More information on registration and use as well as a REMOTE SERVICE user manual (order no. 1019772-...) can be found on the homepage of Globalservice: www.jk-globalservice.de.

4.7 Maintenance plan

 **WARNING!**



Only use genuine spare parts of the same type! If other parts are used then the device no longer complies with the conformity declaration and may not be operated any longer!

Any liability for damage or injury proven to be the result of the use of non-genuine spare parts is excluded.

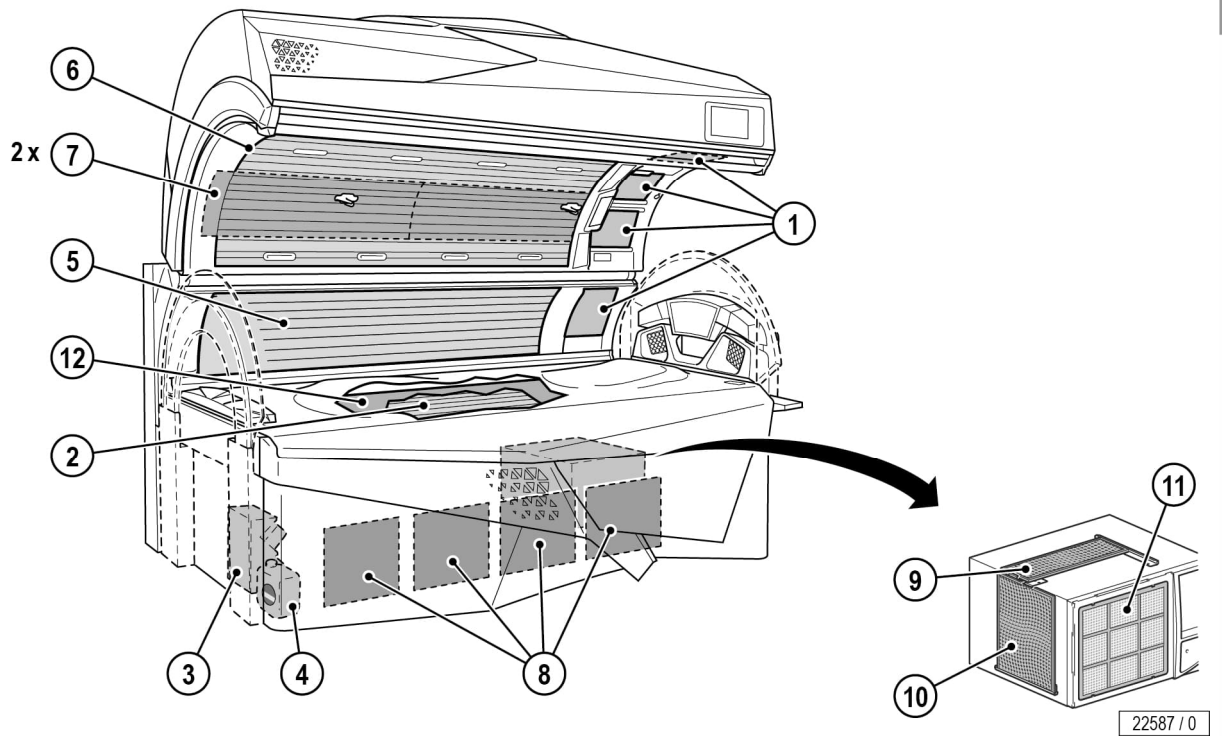

Component	Interval						Activity	See page
	When necessary	300 Operating hours	500 Operating hours	800 Operating hours	1000 Operating hours	3000 Operating hours / 2 years		
1 Low-pressure lamp, facial tanner			X					Replace 69, 74
1 High pressure lamps, facial tanner				X				Replace 74
1 Filter panel, facial tanner						X		Visual inspection 74
1 Filter panel, facial tanner							X	Replace 63
1 Starter, Low-pressure lamps, facial tanner						X		Replace 74
2 Low-pressure lamps, base					X			Replace 72
3 AQUA SYSTEM	X							Replace 81
4 AROMA tank		X						Replace 81
5 Low-pressure lamps, side section					X			Replace 73
6 Low-pressure lamps, canopy					X			Replace 74



Component	Interval						Activity	See page
	When necessary	300 Operating hours	500 Operating hours	800 Operating hours	1000 Operating hours	3000 Operating hours / 2 years		
7 Filter mat					X		Replace	77
8 Filter						X	Replace	76
9 Filter						X	Replace	78
10 Filter						X	Replace	78
11 Filter mat						X	Replace	78
12 Partition						X	Replace	57

Maintenance performed by authorized, trained and qualified staff

 **WARNING!**



Danger to people from maintenance work that has not been carried out!

If maintenance work is not carried out, it can lead to material damage or personal injuries!

- Maintenance work may only be carried out by trained and skilled personnel who have been authorised, instructed and qualified by JK-International GmbH, JK-Global Service department!
- The operator is responsible for compliance with the maintenance intervals!



The maintenance work must be carried out in accordance with checklist 1019858-.. by a JK Factory Certified Technician at the manufacturer or by personnel who have been authorized, trained and qualified by the manufacturer.

The correctly carried out maintenance work must be entered and confirmed in checklist 1019858-..

The maintenance work must be carried out at the following intervals:

- Every 1500 hours
- Annually or every 2000 hours, whichever is sooner.
- Every 3000 hours
- Every 5000 hours
- After 10 years or 20,000 hours, whichever is sooner.

Once the age of the unit reaches ten (10) years from the date of manufacture, its condition must be assessed by a JK-International GmbH, Division JK-Global Service Certified Technician before use of the unit can be continued.

Failure to have this unit assessment performed may result in personal injury or property damage.

Any liability is excluded if use of the unit continues ten (10) years after the date of manufacture, without the "condition assessment" having been performed.



4.8 Cleaning and maintenance work preparation

4.8.1 Service kit

1. Allen key
2. Suction cup for filter panels, acrylic glass panel and canopy panel
3. Scratch prevention for the entry area (support cushion for the canopy)

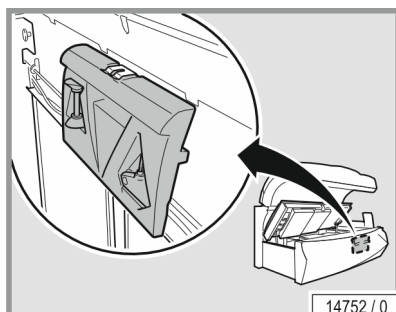
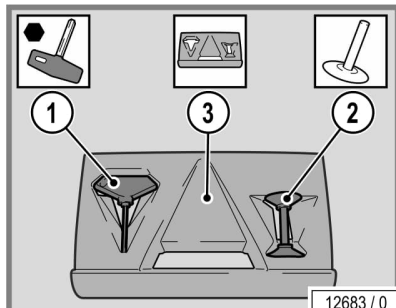

The service kit is fitted on the inside of the front panel.

- Opening the bed base: see page 66.

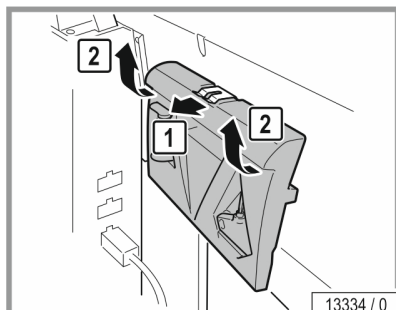

- Remove service kit from holder.

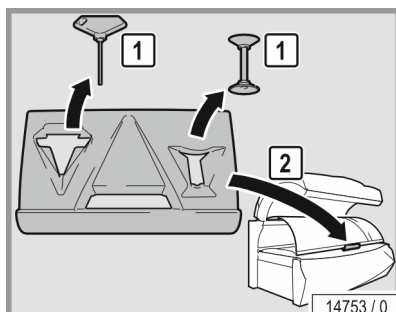

- Remove the Allen-key and suction cup.

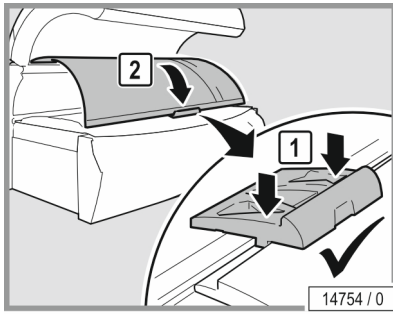

- Use the cushion as scratch prevention when opening the canopy panel.



4.8.2 Lift up the acrylic glass panel and remove the partition

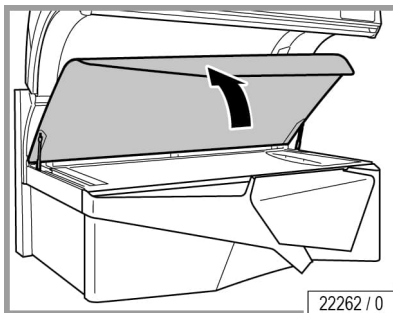

- Lift the acrylic glass panel up to the stop. The acrylic glass panel will automatically be held in place.

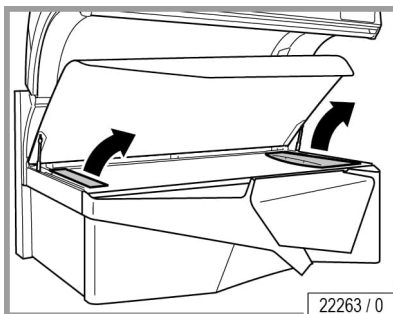

- Remove the lamp covers at the head and foot ends.

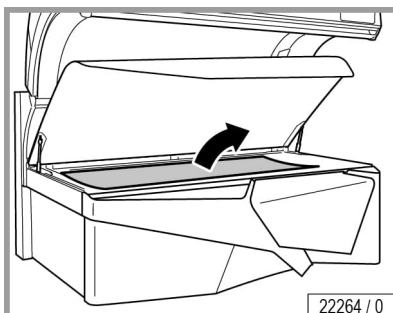

- Raise the partition with the suction cup.
- Remove the partition.

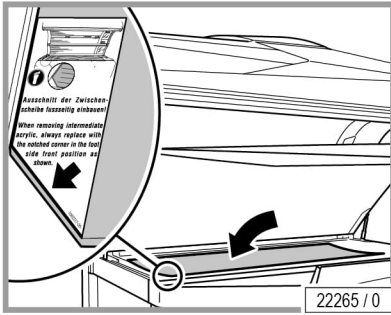

The assembly is the same process in reverse order.

When assembling the device please note:

- You must ensure that the recesses are at the foot end when you fit the partition.

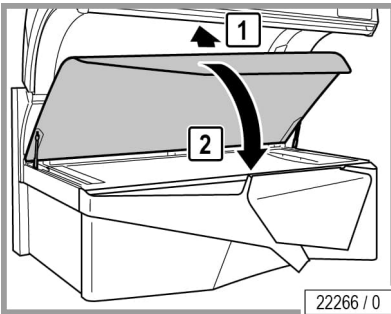

- Lift the acrylic glass panel up slightly and then close it.

4.8.3 Removing the canopy panel

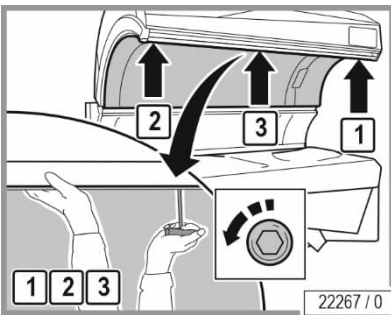

- Turn the locks through 90°: first the outer locks, then the lock in the middle.
- Support the canopy panel with one hand so that it does not fall down.

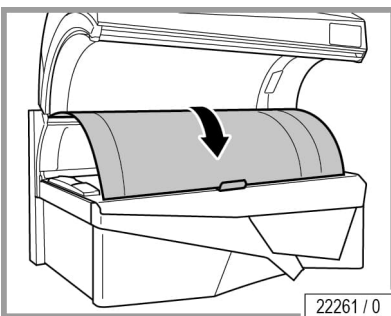

- Carefully lay the panel aside on the scratch protection (service kit).

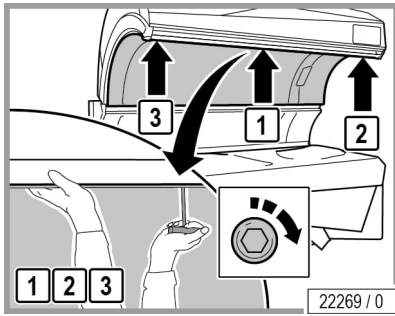

The assembly is the same process in reverse order.

When assembling the device please note:

- Support the canopy panel with one hand so that it does not fall down.
- Re-lock the locks: first the lock in the middle, then the outer locks.



4.8.4 Removing the side section panel

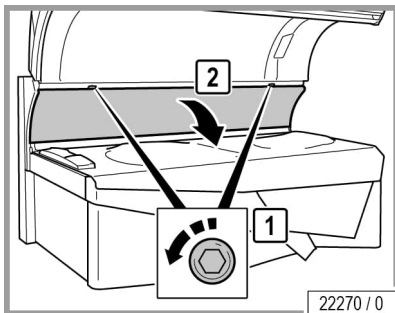

- Turn the locks through 90°.

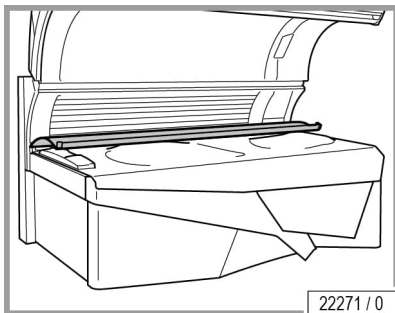

- Open the panel and lay it down carefully.

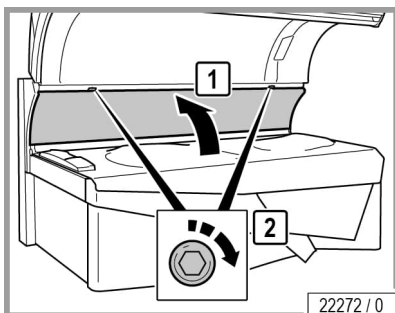

When assembling the device please note:

- Re-lock the locks.

4.8.5 Opening the bed base

- Insert the tank hook into the opening and hook it into the locking bar.

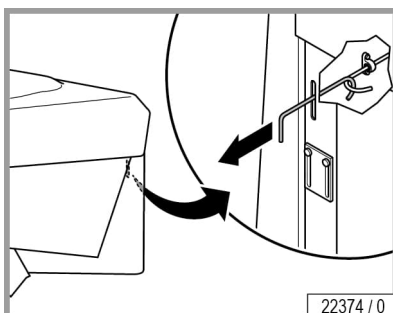
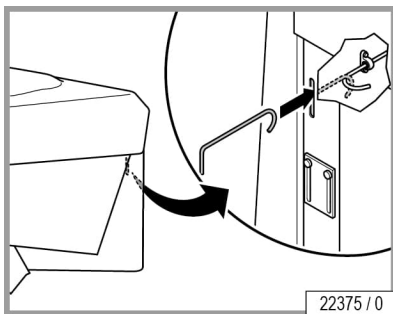

- Pull the tank hook forwards.
- Press the tub down slightly.

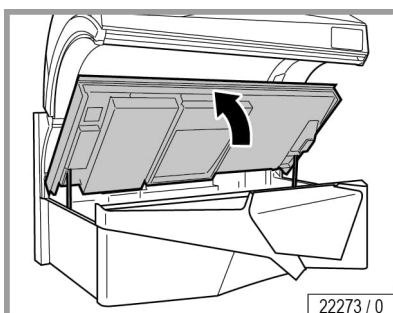

The bed base opens automatically.

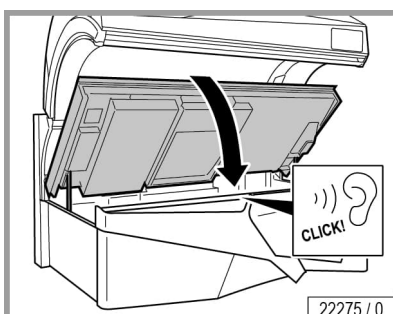

- Close the bed base. You should hear the bed base click into place.

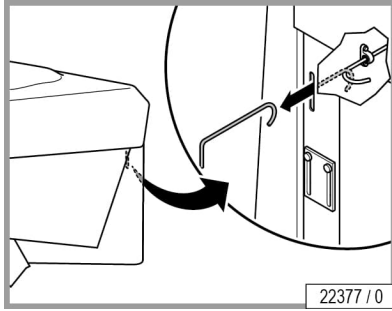

- Remove the tank hook from the opening.



4.9 Instructions for replacing the lamps

DANGER!



Danger of burns from hot lamps and surfaces!
Finger and hands may get burned when replacing lamps.

- Before carrying out maintenance work, wait until the device has cooled down sufficiently.



NOTICE:

Small quantities of mercury can escape if the lamp glass breaks! Please comply with the following instructions:

- Immediately disconnect the device from the mains power.
- Children must leave the room immediately.
- Ventilate the room for at least 15 minutes.
- Put on disposable gloves.
- With the window open: Collect the glass shards and escaped mercury in a sealable container.
- Bring the container to a collection site for waste lamps.



4.9.1 NFC: Lamp replacement

Each new lamp set must be activated with the accompanying NFC lamp card. Each NFC lamp card can only be used one time, then it is invalid.

The lamp set must be installed first, then the lamps have to be activated with the NFC lamp card. For this purpose, the operating hours must be reset.

Resetting the operating hours



NOTE:

To reset the operating hours of the lamps, you need access to the PROFESSIONAL SETUP MANAGER PLUS.

- Go to PROFESSIONAL SETUP MANAGER PLUS.
- Activation in the menu OPERATING HOURS.

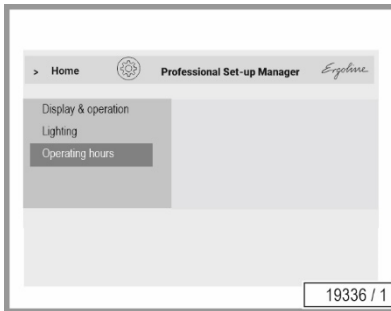

- Hold the NFC lamp card against the NFC point.



The middle point of the NFC point is green:
The operating hours of the lamps are reset to 0.

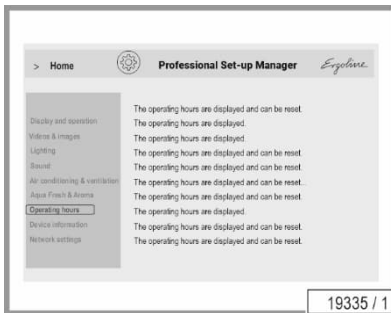

NOTE:

Both NFC lamp cards must be activated. Hold the NFC lamp card of lamp set type A and the NFC lamp card of lamp set type B against the NFC point one after another.

4.9.2 Low-pressure lamps

! DANGER!



Danger of burns from hot lamps and surfaces!
Finger and hands may get burned when replacing lamps.

- Before carrying out maintenance work, wait until the device has cooled down sufficiently.

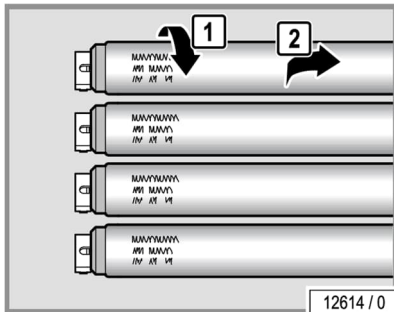

12614 / 0

- Replace faulty low-pressure lamps immediately.
- Always replace the entire set of lamps after the specified operating time.
- Turn 90° and carefully remove from the socket.

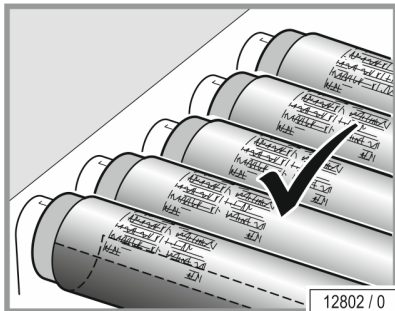

12802 / 0

- Low-pressure lamps possess a reflector which directs the light outwards.
- The lamps must be mounted so that the rear side of the reflector faces the interior of the unit.

! WARNING!



Risk of fire due to incorrect alignment of the lamps!
Incorrect alignment of the lamps leads to loose connections. This can cause overheating and sparking.

- Check that the socket is correctly aligned!

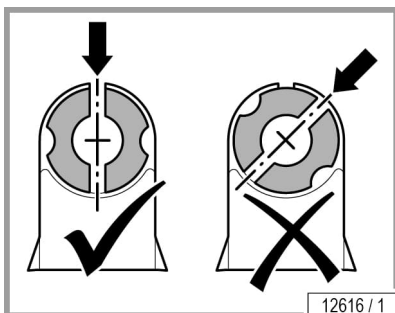

12616 / 1

- Before inserting the new lamp, the alignment of the inner part of the socket must be checked.

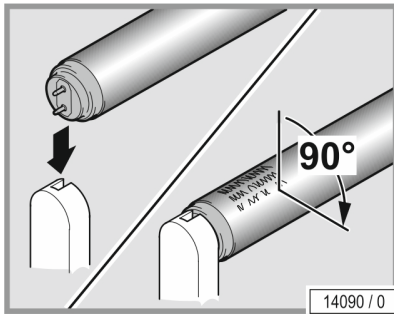

- Insert the contact pins of the lamps vertically into the socket from above.
- For correct contacting, the lamp must be rotated 90° around its own axis.
- The lettering must be oriented towards the outside (i.e. towards the tanning room or towards the user).

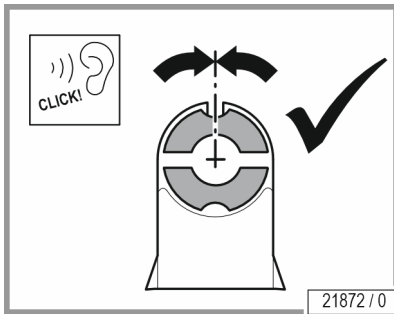

4.9.3 Starter

- Replace faulty starters immediately.

You can recognize a faulty starter by the blackened ends of the (UV) low-pressure lamps or when the (UV) low-pressure lamps can no longer be started.

Operating a (UV) low-pressure lamp with a faulty starter significantly shortens its service life. The (UV) low-pressure lamp loses power and may begin to flicker under certain circumstances.

The starters are located in either one of the two lamp sockets or become visible when the (UV) low-pressure lamps are removed.

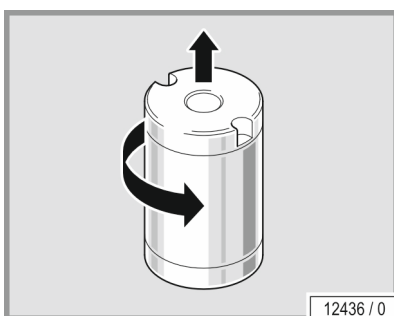

- Turn 90° and carefully remove from the socket.

4.9.4 High pressure lamps and filter panels

High-pressure lamps are used in the facial tanners.

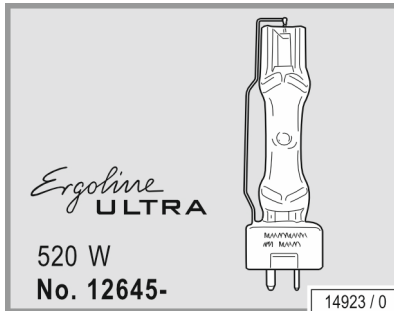

 **DANGER!**



Danger of burns from hot lamps and surfaces!

Finger and hands may get burned when replacing lamps and filter panels or cleaning reflectors.

- Before carrying out maintenance work, wait until the device has cooled down sufficiently.

 **DANGER!**



Fire hazard due to overheated lamps!

Non-approved high pressure lamps can explode. Hot lamp components can set other parts on fire. People can be killed or severely injured due to smoke inhalation and fire.

- Only fit the high pressure lamps specified by the manufacturer.
- Clean the inside of the device regularly. Dust particles are flammable!

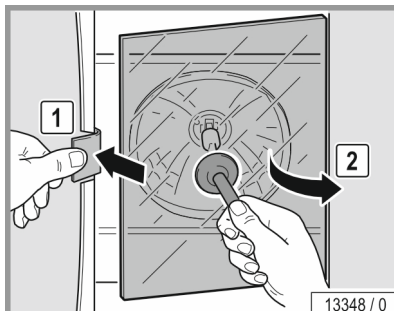

- Open the clamps.
- Lift the filter panel, pull it out of the guide and remove it.



- Unplug the lamps.
- Clean the reflector.

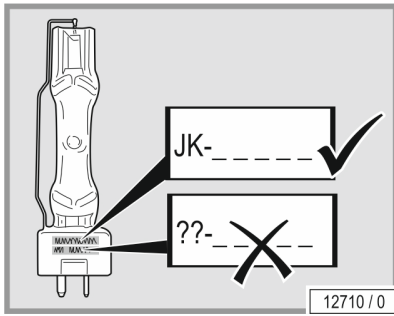

- Only utilize original lamps.

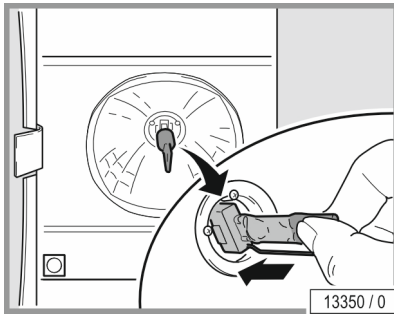

- Only touch new lamps in the handling zone.

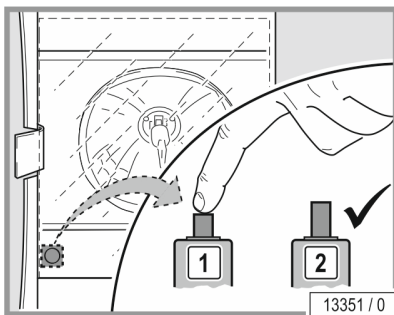

- Test the function of the safety switch. The safety switch ensures that the device switches off in the event of a faulty filter panel.
- Press the switch. If the switch springs back automatically then it is functional.
- Replace the filter panel.

4.10 Cleaning or replacing lamps in the base

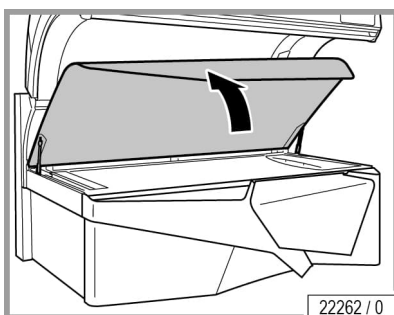

- Lift up the acrylic glass panel and then remove the lamp covers and the partition: see page 63.

Replacing lamps: see page 69.

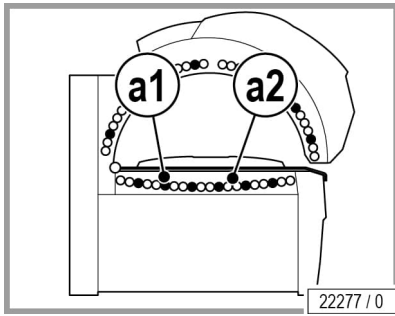

- Please maintain the correct order of the SMART SUN low pressure lamps and UV low-pressure lamps.
a1: SMART SUN low pressure lamps
a2: UV low pressure lamps

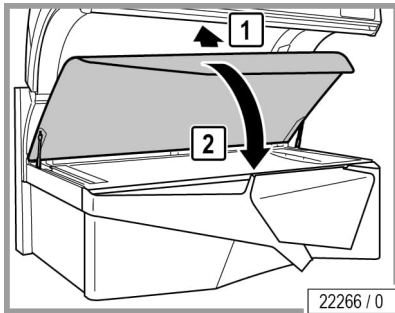

The assembly is the same process in reverse order.

When assembling the device please note:

- You must ensure that the recesses are at the foot end when you fit the partition.
- Lift the acrylic glass panel up slightly and then close it.

4.11 Cleaning or replacing the lamps in the side section

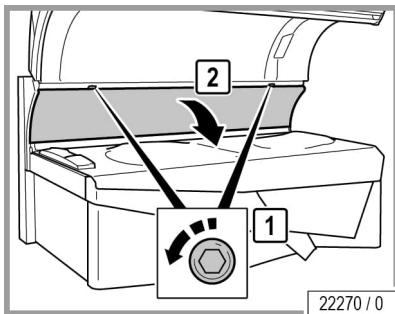

- Removing the side section panel: see page 65.

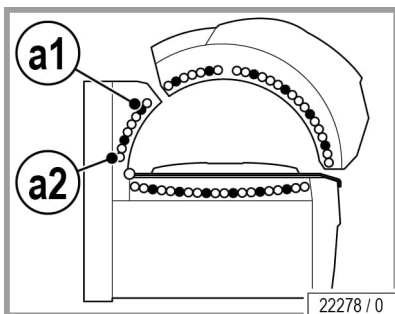

- Please maintain the correct order of the SMART SUN low pressure lamps and UV low-pressure lamps.
a1: SMART SUN low pressure lamps
a2: UV low pressure lamps

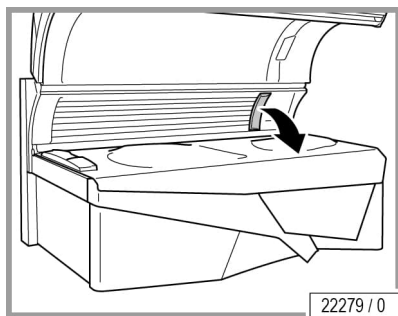

22279 / 0

- Remove the lamp cover.

Replacing the lamps:
Low-pressure lamps: see page 69.

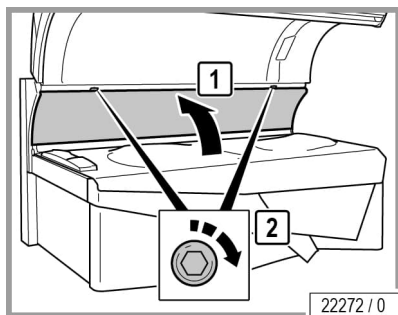

22272 / 0

When assembling the device please note:

- Re-lock the locks.

4.12 Cleaning or replacing lamps and filter panels in the canopy

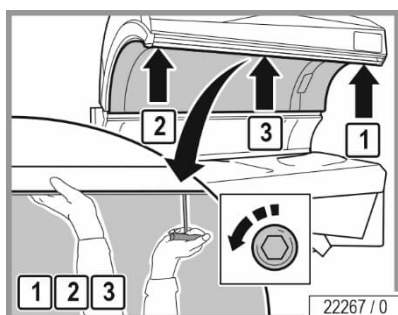

22267 / 0

The following components listed in the maintenance plan are fitted in the canopy:

- Low pressure lamps 1,80 m

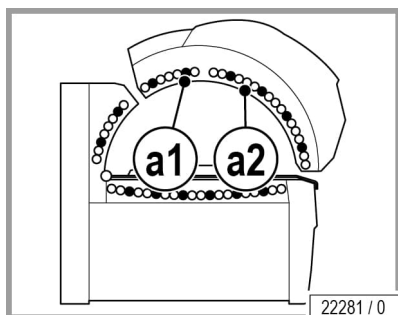

22281 / 0

- Please maintain the correct order of the SMART SUN low pressure lamps and UV low-pressure lamps.
a1: SMART SUN low pressure lamps
a2: UV low pressure lamps

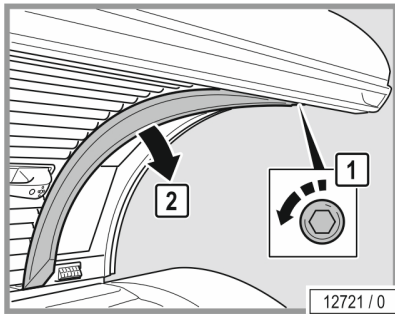

- Remove screw and place the lamp cover carefully on top of the canopy panel.

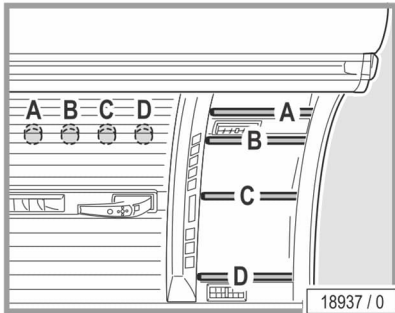

The facial tanner's low pressure lamps must be removed first so that the high pressure lamps can be changed.

- Remove the lamps.

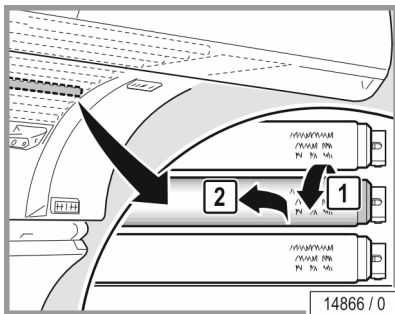

- Remove the ninth low-pressure lamp in the canopy so that you can access the facial tanner's low-pressure lamp starters.

Replacing lamps:

Low pressure lamps: see page 69.

High pressure lamps and filter panels: see page 71.

Replacing starters: see page 70.

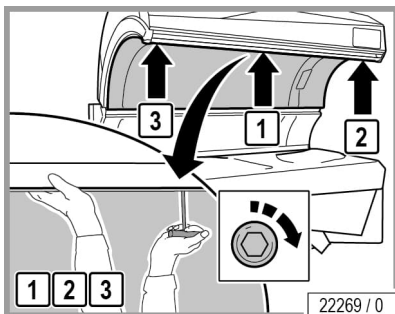

The assembly is the same process in reverse order.

When assembling the device please note:

- Support the canopy panel with one hand so that it does not fall down.
- Re-lock the locks: first the lock in the middle, then the outer locks.

4.13 Cleaning the filters in the base

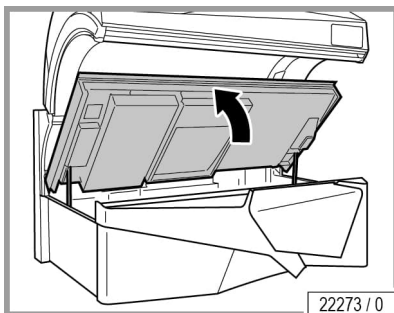

- Opening the bed base: see page 66.

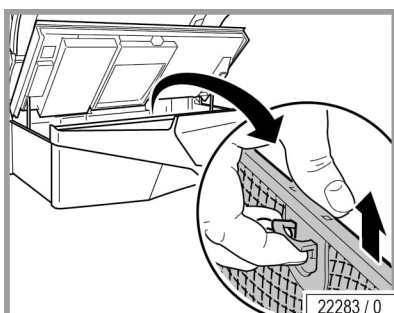

- Remove the filters.

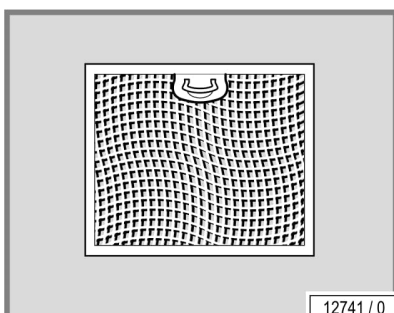

- Cleaning the filters when moist or dry.

Dry cleaning: Vacuum cleaner (depending on the degree of soiling)
 Moist cleaning: Use water and detergent or put in a dish-washer

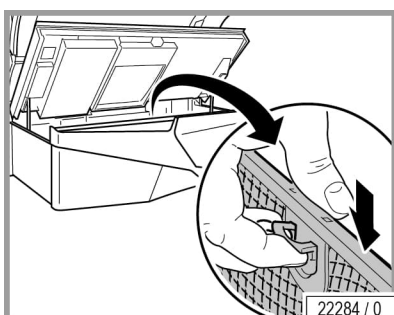

- Refit the cleaned and dried filters.
- Close the bed base. You should hear the bed base click into place.

! WARNING!



The device may be damaged by moisture!
 The cleaned filters must be dry before they are replaced.

4.14 Cleaning the canopy filter mats

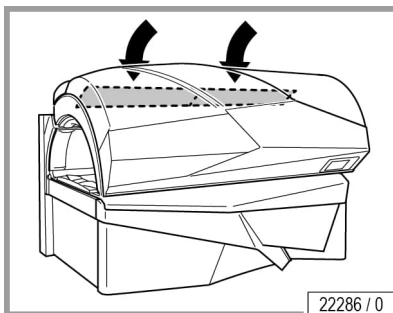
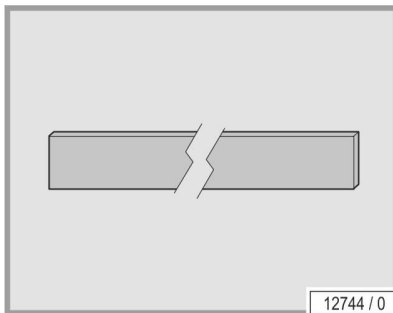
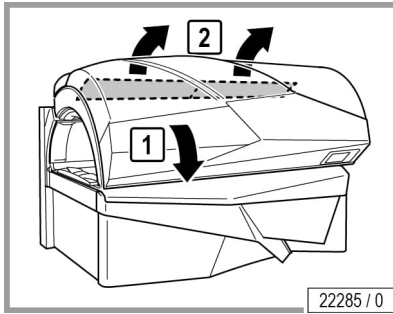

- If necessary, cover the canopy in order to prevent the paint from being scratched.
- Remove the filter mats fitted at the back of the canopy.

- Dry or moist clean the filter mats or replace with new ones.

Dry cleaning: Vacuum cleaner (depending on the degree of soiling)

Moist cleaning: water and detergent

- Do not clean in the dish-washer!

! WARNING!



The device may be damaged by moisture!

The cleaned filters must be dry before they are replaced.

- Refit the cleaned and dried filter mats.



4.15 Air conditioning: Empty the condensation tank and cleaning the filter

 CAUTION!



Inflammable refrigerant in the air conditioning system!

Leaking refrigerant can lead to fires or explosions.

- Avoid sources of ignition! Fire, naked flames and smoking are prohibited.
- No servicing work may be carried out on components in the cooling circuit, e.g. on the compressor, pressure switch or frequency inverter.
- Do not perform any soldering or welding work on the unit.



NOTE:

The filter surfaces must be free from contamination. The filters must be cleaned regularly in accordance with the specifications in the cleaning plan.



NOTE:

The air conditioner contains fluorinated greenhouse gases. Do not release gases into the atmosphere. Information regarding the refrigerant used::

Currently in use are refrigerant R32 (⁽¹⁾GWP: 675) used with a charge of 0.45 kg.



NOTE:

Details on the refrigerant used and the amount can be found on the type plate of the air conditioning system.

- Opening the bed base: see page 66.

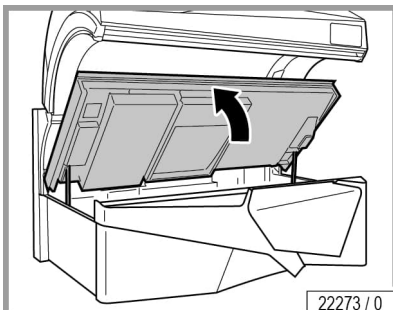

¹ GWP = global warming potential

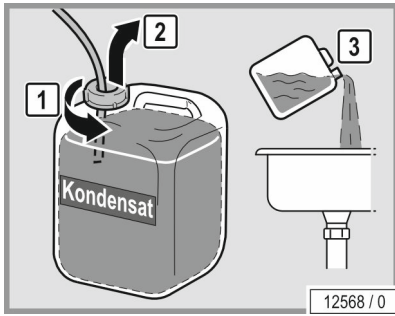

- Bring the condensation tank forwards.
- Disconnect the hose on the condensation tank.
- Empty the condensation tank.

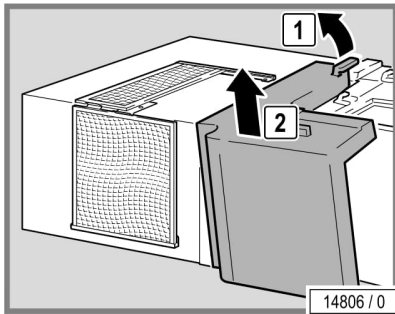

- Remove the cover.

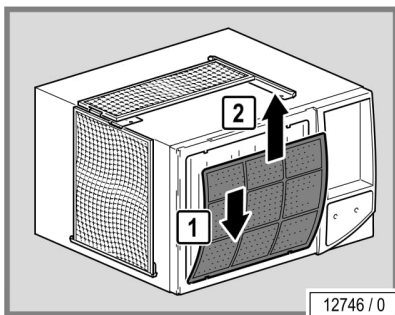

- Remove the filter from the holder.

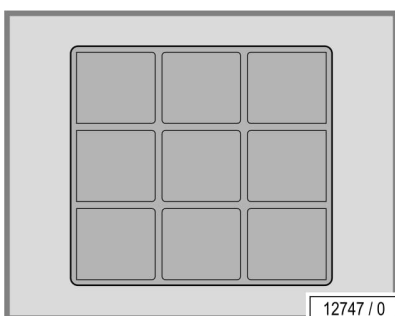

- Cleaning the filters when moist or dry.

Dry cleaning: Vacuum cleaner (depending on the degree of soiling)

Moist cleaning: Water and detergent

- Do not clean in the dish-washer!

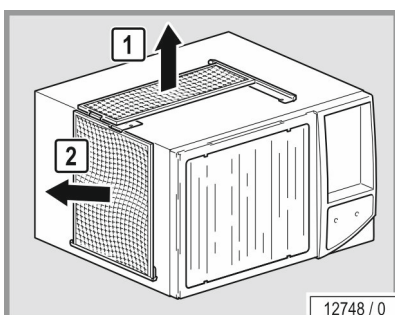

- Remove the filter from the holder.

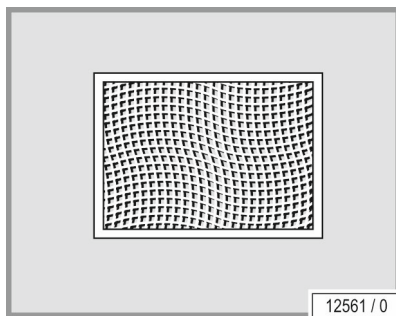

- Cleaning the filters when moist or dry.

Dry cleaning: Vacuum cleaner (depending on the degree of soiling)

Moist cleaning: Use water and detergent or put in a dish-washer

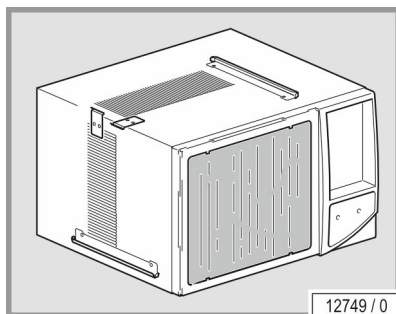

- Use a fin comb to clean the air conditioning's dirty cooling fins.

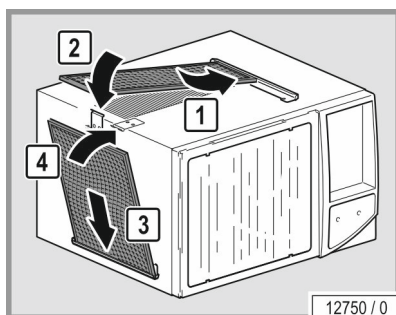

WARNING!



The device may be damaged by moisture!
The cleaned filters must be dry before they are replaced.

- Refit the cleaned and dried filters.
- Ensure that the filters are correctly positioned in the holder.

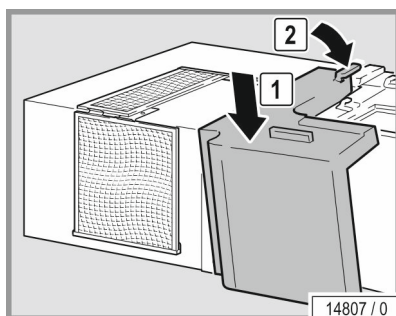
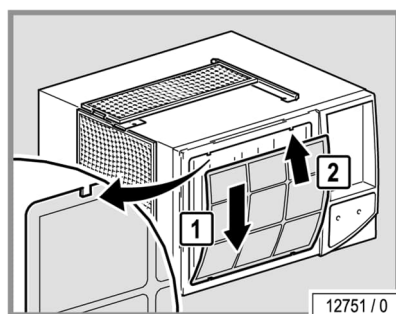

- Attach the cover.

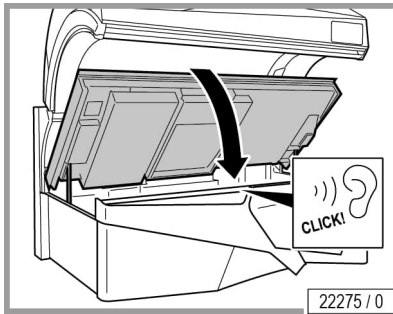

- Connect the condensation tank to the hose.
- Refit the condensation tank.
- Close the bed base. You should hear the bed base click into place.



4.16 AQUA / AROMA system maintenance

The AQUA SYSTEM function sprays a fine mist of AQUA SOLAR WITH SKIN+ ADDITIVE into the interior of the device for body cooling (see 'AQUA SYSTEM PRODUCT INFORMATION', order no. 1011201-..).

DANGER!



Customer health hazard!

Water that has been contaminated with bacteria can cause skin rashes and other allergic reactions in device users.

- Therefore you must never fill the AQUA SYSTEM canister with tap water or other liquids.
- Only replace the AQUA SYSTEM canister with a genuine canister.
- Do not add any liquid that remains in the old canister to the new canister!
- Ensure that the maximum temperature specified is not exceeded during transport and storage.
- Note the expiry date on the canister.



The AQUA / AROMA SYSTEM also includes the fragrance 'RELAX' which is distributed via the head nozzles as well as in the cabin.

Other fragrances are also available. Contact JK-International GmbH, Division JK-Licht for further details (see page 2).

4.16.1 Changing the AROMA canister

- Opening the bed base: see page 66.

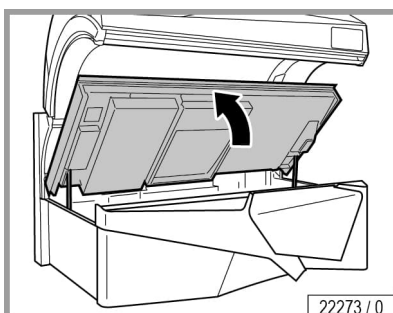

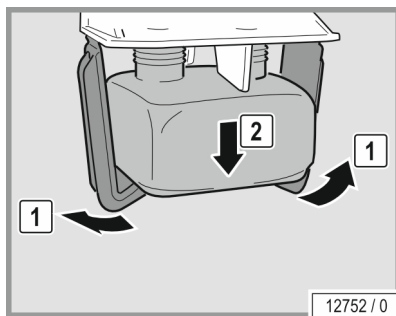

- Remove the AROMA canister.

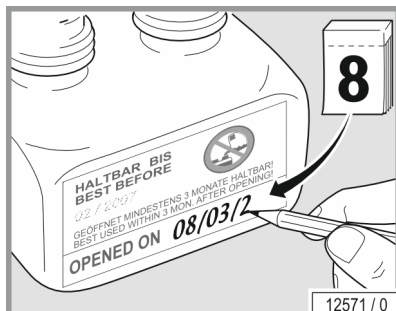

- Unscrew the lid on the new canister.
- Write the date on the canister.

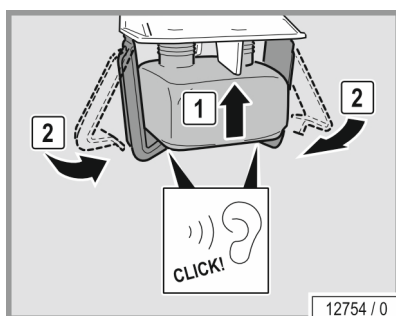

- Fit the canister in the holder.
- Close the bed base. You should hear the bed base click into place.

4.16.2 Replacing the AQUA SYSTEM canister

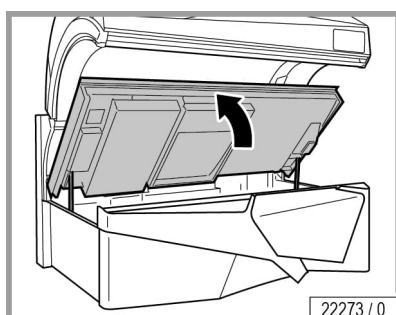

- Opening the bed base: see page 66.

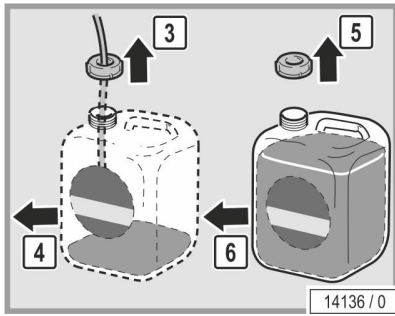

- Remove the canister.
- Unscrew the lid on the new canister.
- Remove the lid with the hose from the old canister.

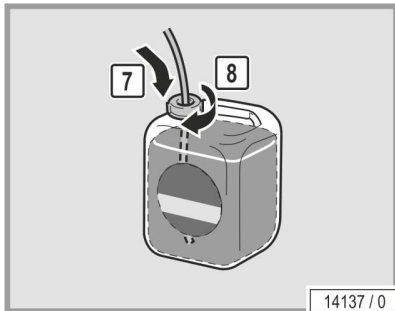

- Screw the lid with the hose onto the new canister.
- Push the hose well down so that it touches the bottom of the canister.
- Put the canister back in the device.
- Close the bed base. You should hear the bed base click into place.

Venting



NOTE:

To ventilate, access to PROFESSIONAL SETUP MANAGER PLUS is required.

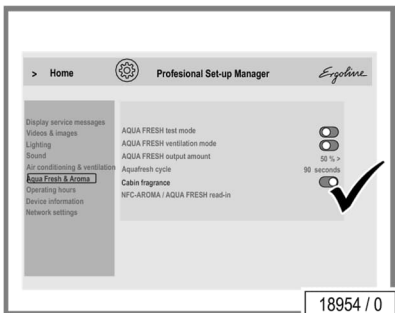

- Go to PROFESSIONAL SETUP MANAGER PLUS.
- Activate the fill mode in the AQUA FRESH & AROMA menu.

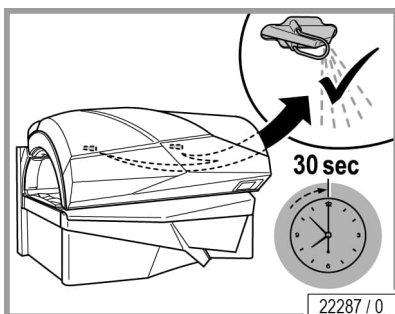

- Close the canopy.
- The system will now be ventilated for 30 seconds. The AQUA SYSTEM liquid will be released from the nozzles during this period.
- Then test the AQUA SYSTEM in test mode. In test mode, the nozzles spray for 3 seconds. Repeat the ventilation process if it does not work.

5 Technical data



5.1 Power, connection rating and noise level

Prestige Fusion Edge			
Power consumption rating with Climatronic:	15600 W		
Rated frequency:	50 Hz		
Rated voltage:	400-415 V 3N~		230-240 V ~3
Rated fuses:	3 x 35 A (inactive)	or	3 x 50 A (inactive)
Connecting line:	H05VV-F 5G 4 mm ² (scope of delivery)		H05VV-F 4G 10 mm ²
Noise level 1m away from device:	66,9 dB(A)		
Noise level inside the device:	<70 dB(A)		
Load on the acrylic glass panel:	max. 135 kg		
Weight:	615 kg		

5.2 Dimensions

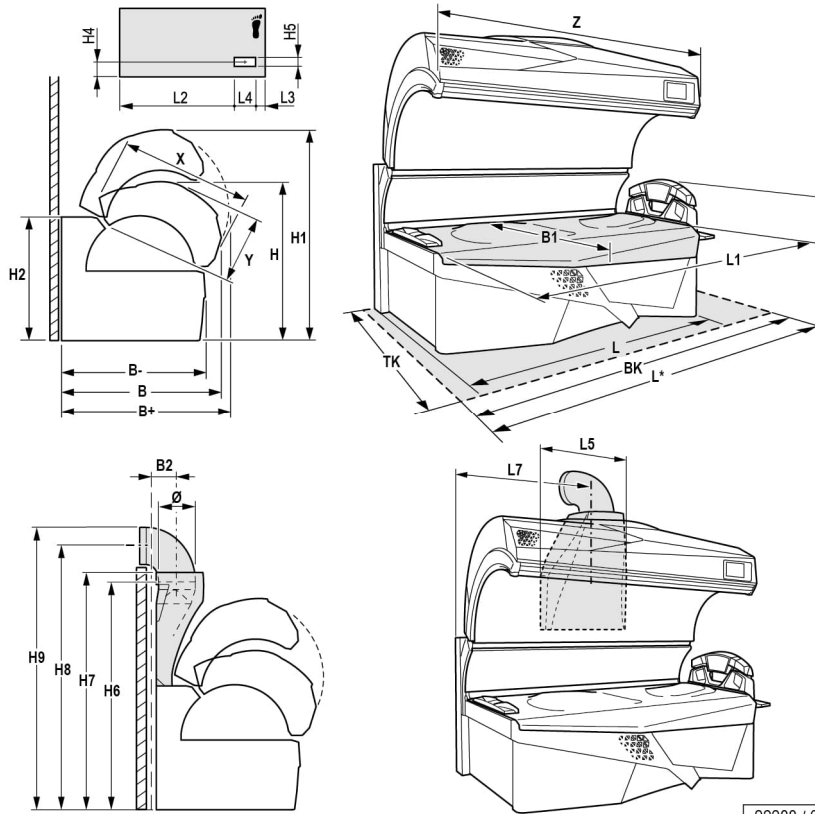

B + = 1555 mm	H5 = 100 mm
B = 1545 mm	H6 = 1873 mm
B - = 1495 mm	H7 = 2005 mm
B1 = 875 mm	H8 = 2219 mm
B2 = 225 mm	H9 = 2362 mm
L = 2247 mm	X = 1132 mm
L* = 2411 mm	Y = 785 mm
L1 = 2200 mm	Z = 2238 mm
L2 = 1767 mm	D = 300 mm
L3 = 235 mm	BK = 2500 mm
L4 = 245 mm	TK = 2300 mm
L5 = 645 mm	
L7 = 1120 mm	
H = 1540 mm	
H1 = 2055 mm	
H2 = 1108 mm	
H4 = 445 mm	

*(shoulder tan with sound system / audio system)



5.3 Lamp sets

 **WARNING!**



The conformity declaration applies for the specified lamps and filter panels. The use of other lamps and filter panels voids the operating licence.

Moreover, the lamps must be marked with a matching equivalence key, see attachment page 89.

The UV lamps used are broadband radiators that can be operated with different wattages (approx. 240-520 W).

5.3.1 Prestige Fusion Edge

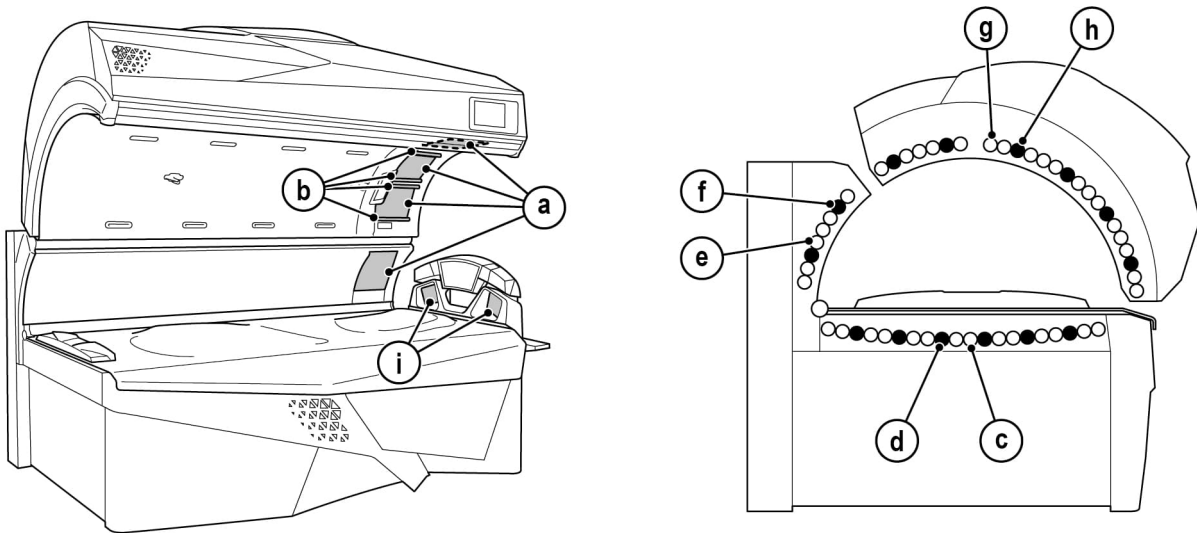

22289 / 0

Lamp set

	Number	Description	Length	Power	Control	Order-no.
a)	4	UV high pressure lamps Ergoline Ultra		520 W	420 W / 360 W / 260 W / 0 W	12645-..
	2	Filter panels ULTRA PERFORMANCE 862H				1511229-..
	2	Filter panels ULTRA PERFORMANCE 862				1004204-..
b)	4	SMART SUN 53 8 W				1512995-..
	4	Starter S10 (5-65 W)				10047-..
c)	14	UV low-pressure lamps ERGOLINE TREND ADVANCED 80-200 EP104 160W R	1,80 m	160 W	80-200 W	1511231-..
d)	6	Low-pressure lamps SMART SUN R 28 80-200 160 W	1,80 m	160 W	80-200 W	1518419-..
e)	6	UV low-pressure lamps ERGOLINE TREND ADVANCED 80-200 EP104 160W R	1,80 m	160 W	80-200 W	1511231-..

	Number	Description	Length	Power	Control	Order-no.
f)	2	Low-pressure lamps SMART SUN R 28 80-200 160 W	1,80 m	160 W	80-200 W	1518419-..
g)	18	UV low-pressure lamps ERGOLINE TREND ADVANCED 80-200 EP104 160W R	1,80 m	160 W	80-200 W	1511231-..
h)	6	Low-pressure lamps SMART SUN R 28 80-200 160 W	1,80 m	160 W	80-200 W	1518419-..
i)	2	Ergoline UV LED Board shoulder tan	Not a wear part			1513795-..



5.4 Spare parts and accessories

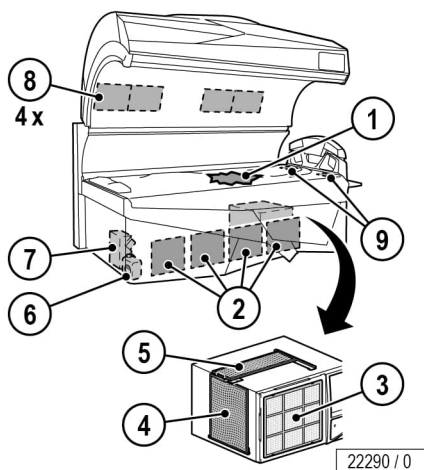

Number		Description	Order-no.
1	1	Partition	1518103-..
2	4	Filter	52104-..
3	1	Filter mat	—
4	1	Filter	51937-..
5	1	Filter	55567-..
6	1	AQUA SYSTEM, 6000 ml	800617-..
7	1	AROMA, 100 ml RELAX	701357-..
8	2	Filter mats	843150-..
	1	Protective goggles	1027211-..
	1	Tank hook	1517832-..
	1	NFC lamp card for the UV lamp set	1511265-..
	1	NFC lamp card for the SMARTSUN lamp set	1511266-..

6 Appendix



6.1 JK timer controls

The following time control system can be utilised with the PRESTIGE series units:

HK MICROTIMER 8250 order no.: 500001653

6.2 Equivalence key range

Example for calculating the equivalence key range (1), see the lamp configuration sticker:

If the equivalence key of the lamp with which the device has been equipped during the type approval is

100-R-47/2,7

the equivalence key range with which the device should be marked is calculated as follows:

Bottom value of the X section: $0,75 \times 47 = 35,25$

Bottom value of the Y section: $0,75 \times 2,7 = 2,03$

Top value of the Y section: $1,25 \times 2,7 = 3,38$

X is rounded up to the next whole value, Y will be rounded to the first decimal place after the point.

The equivalence key range for fluorescent lamps is then:

100-R-(35-47)/(2,0-3,4)

				Ergolite E8P8T 170-S DYNAMIC POWER			
	①	18x			Ergolite TREND 80-200 W E8	1604286- 100-R- (35-47)/(2,0-3,4)	
	②	8x			Ergolite TREND 80-200 W E8	1604286- 100-R- (35-47)/(2,0-3,4)	
	③	32x			Ergolite TREND 80-200 W E8	1604286- 100-R- (35-47)/(2,0-3,4)	
	④		4x	2x	Ergolite ULTRA 82W ULTRA PERFORMANCE 802	1604284- 1604284- 1604284- 1604284- 1604284-	
	⑤	-	-	-	Ergolite TREND 80-200 W E8	-	100-R- (35-47)/(2,0-3,4)
 Ergolite E8P8T 170-S max. 170 W		2x	2x	Ergolite ULTRA 100 W ULTRA PERFORMANCE 802 ULTRA PERFORMANCE...	1604284- 1604284- 1604284-		
JK-Products GmbH / GERMANY				1000000-01			

13192 / 1



6.2.1 Description of the equivalence keys for fluorescent lamps

The equivalence key for fluorescent lamps for tanning that is represented in detail in the IEC 61228 and that is marked on the lamp in a readable and permanent manner, is described in the following.

The equivalence key has the following structure:

Wattage – Reflector type key – UV key.

The following reflector type key should be used for the equivalence key:

O with lamps without reflector;

B with lamps that have a wide reflecting angle $\alpha > 230^\circ$;

N with lamps that have a narrow reflecting angle $\alpha < 200^\circ$;

R with lamps that have the usual reflecting angle $200^\circ \leq \alpha \leq 230^\circ$.

The following UV key should be used for the equivalence key:

UV key = X/Y;

X = the entire effective erythematic UV radiation strength across the range 250 nm to 400 nm;

Y = the relationship of the non-melanoma skin cancer effective UV radiation strength ≤ 320 nm and > 320 nm.

X is specified in mW/m^2 and rounded up to the next whole value, Y will be rounded to the first decimal place after the point. The effective values apply for a distance of 25 cm and under the conditions of an optimum UV radiation strength.

Note

One example for an equivalence key is specified below:

- 100 W reflector lamp with a reflector angle of 220°
- erythematic UV radiation strength (250 nm to 400 nm) = $47 \text{ mW}/\text{m}^2$
- short wave NMSC effective UV radiation strength (≤ 320 nm) = $61 \text{ mW}/\text{m}^2$
- long wave NMSC effective UV radiation strength (> 320 nm) = $19 \text{ mW}/\text{m}^2$
- lamp equivalence key: 100–R–47/2,7

7 Index



A

Accessories.....	32, 88
Acrylic glass (care)	55
Acrylic glass panel - sunbed	57
Acrylic glass panel, permitted load.....	84
Acrylic glass panels (product information).....	57
Adolescents	8, 33
Allergies.....	33
AQUA / AROMA system maintenance.....	81
Assembly.....	15
Audio files	20

B

Bluetooth®	49
------------------	----

C

Care	54
Changing the AROMA canister	81
Children	11
Cleaning.....	53, 54
Air conditioning	78
Air conditioning filter	78
Filter mats.....	77
Lamps, filter panels	55
Cleaning intervals	56
Cleaning or replacing	
Side section	73
Cleaning or replacing lamps	
Base.....	72
Cleaning or replacing the lamps	
Facial tanner	74
Cleaning overview.....	56
Cleaning the filter.....	76, 77
Cleaning, filter	76
Commissioning.....	17
Contact lenses	33
Cosmetics	11
Customer service.....	2



D

Damage	28
Decommissioning.....	18
Definitions	6
Description.....	30
Device operating time	17
Dimensions	85
Directives	20
Disposal	19

E

Electrical installation	15
Electrical specifications	84
Emptying the condensation tank.....	78
Equipment	29
Equivalence key range.....	89
Error codes.....	54
Exhaust air ventilation	15
Export	20
EXTERIOR DISPLAY	40
Eye damage	33

F

Facial tanner	
Cleaning or replacing	74
Faults.....	54
Filter	
Cleaning intervals.....	56
Filter panels	71
Cleaning or replacing	74
Foreseeable misuse	8
Functions	38

H

High pressure lamps, danger of fire!	71
--	----

I

Illnesses	33
Intended use	8
INTERIOR DISPLAY.....	43
Itching	33

L	
Lamp sets.....	86
Lamps.....	8
Control.....	86
Power levels.....	86
Rated power.....	86
Liability.....	28
Lift up the acrylic glass panel.....	63
Light sensitivity.....	33
M	
Maintenance.....	53, 57
Maintenance intervals.....	58
Maintenance overview.....	58
Make-up.....	33
Medicaments.....	33
Music.....	20, 52
N	
Network.....	58
NFC.....	68
NFC Connect.....	37
Noise level.....	84
O	
Opening the bed base.....	66
Operating altitude.....	16
Operating overview.....	35
Operator's obligations.....	14
Order numbers.....	86, 88
P	
Packaging.....	19
Performance rights.....	20
Personnel training.....	14
Plastic surfaces (care).....	55
Plug-in connector.....	15
Power.....	84
Preclusion of damage.....	28
PROFESSIONAL SETUP MANAGER PLUS.....	36
Prohibited usage.....	9
Protective glasses.....	11
Protective measures when performing maintenance work.....	53





R

Radiation area 52

Recycling 19

Remote SERVICE 58

Removing the canopy panel 64

Removing the side section panel 65

Replace the low-pressure lamps 69

Replacing the AQUA SYSTEM canister 82

Replacing the lamps 67

Restrictions 10

Risk of injury 33

S

Safety 15

Safety instructions

- Device-specific safety instructions 9
- General safety instructions 14

Scope of delivery 14, 29

Service kit 62

Setup 15

Setup location 16

Showering 33

Size 85

Skin sensitivity 12

Skin type 12

Spare parts 58

- Order numbers 88

Starter 86

Starter, replacing 70

Starting the tanning 48

Start-up adjustments 48

Storage 18

Sunburn 33

Symbols 7

T

Tanning times 13

Technical data 84

Time control 17

Transport 15

U

Unit description..... 30
UV exposure..... 11



V

Ventilation 15
Volume 52

