

CE

Operating instructions

Translation of the original operating instructions

Prestige FUSION SPECTRA Hybrid
Prestige FUSION SPECTRA UV Blue

1029170-00A / en / 02.2026

Ergoline

Legal notice



Manufacturer: JK-Products GmbH
Köhlersshohner Straße 60
53578 Windhagen
GERMANY
Tel: +49 (0) 22 24 / 818-0

Customer service / JK-International GmbH,
Technical service Division JK-Global Service
(Spare part orders Köhlersshohner Straße 60
for components): 53578 Windhagen
GERMANY
Tel: +49 (0) 22 24 / 818-861
E-mail: service@jk-globalservice.de

Spare part orders for JK-International GmbH,
consumables: Division JK-Licht
Köhlersshohner Straße 60
53578 Windhagen
GERMANY
Tel: +49 (0) 22 24 / 818-600
E-mail: info@jk-licht.de

DANGER!



Failure to observe these operating instructions:

- may result in serious injury and death,
- can result in damage to the unit and to the environment.
- Read these instructions carefully before putting this unit into operation.
- Please observe the instructions and the code of conduct required to operate the unit safely.
- Please make the operating instructions and additional information from the manufacturer available to the personnel at their workplace.
- Should you sell this unit or give it to another party, please make sure that you provide them with these operating instructions.

Copyright

The copyright remains with JK-Holding GmbH.

The contents may not be partially or completely duplicated, distributed or utilized for competitive purposes without authorization or disclosed to other parties.

The right to make technical changes in regard to the figures and information contained in these operating instructions is reserved!

Table of contents



1	Safety instructions and warnings	6
1.1	General	6
1.1.1	Definitions	6
1.1.2	Symbol explanation	7
1.2	Intended use	8
1.3	Foreseeable misuse	8
1.4	Tanning safety information	9
1.4.1	Prohibited usage	9
1.4.2	Important notes	10
1.4.3	Skin type descriptions	12
1.4.4	Tanning times EN	13
1.5	Safety instructions and warnings	14
1.5.1	Operator's obligations	14
1.5.2	Personnel training	14
1.5.3	Scope of delivery	14
1.5.4	Transport, assembly and setup	15
1.5.5	Commissioning	17
1.5.6	Operation and maintenance	17
1.5.7	Decommissioning	18
1.5.8	Storage	18
1.5.9	Disposal	19
1.5.10	Directives	20
1.5.11	Export	20
1.5.12	Own music	20
1.5.13	Technical modifications	21
1.6	Signs and stickers on the unit	22
1.7	Preclusion of damage	28
1.8	Exclusion of liability	28
2	Description	29
2.1	Scope of delivery	29
2.1.1	Options	29
2.2	Equipment	29
2.3	Unit description	30
2.4	Accessories (optional)	31
2.5	Functional description	31



3	Operation.....	32
3.1	User safety information	32
3.2	Tanning - but correctly!	32
3.3	Operating overview.....	34
3.3.1	PROFESSIONAL SETUP MANAGER PLUS	35
3.3.2	Navigation.....	35
3.4	Functions	36
3.4.1	Navigation.....	38
3.5	Selection of the application type (SELECTABLE TANNING PROGRAMS)	40
3.6	Start.....	41
3.7	Coupling with Bluetooth® devices	42
3.8	Listening to music	44
3.9	Smartphone Wireless Charging (optional).....	44
3.10	Voice control ELECTRONIC VOICE ASSISTANT(E.V.A.) (optional).....	45
4	Cleaning and maintenance.....	47
4.1	Safety instructions when undertaking cleaning or maintenance work.....	47
4.2	Faults.....	48
4.3	Cleaning	48
4.3.1	Cleaning the surfaces	49
4.3.2	Lamps	50
4.3.3	SPECTRA LED boards	50
4.4	Cleaning plan	51
4.5	Maintenance	52
4.5.1	Acrylic glass.....	53
4.5.2	REMOTE SERVICE (optional)	53
4.6	Maintenance plan.....	53
4.7	Cleaning and maintenance work preparation.....	56
4.7.1	Service kit.....	56
4.7.2	Lift up the acrylic glass panel and remove the partition	57
4.7.3	Removing the canopy panel.....	58
4.7.4	Removing the side section panel	59
4.7.5	Opening the bed base	60
4.8	Instructions for replacing the lamps	61
4.8.1	NFC: Lamp replacement	62
4.8.2	Low-pressure lamps.....	63
4.8.3	Starter.....	64
4.9	Cleaning or replacing lamps in the base.....	65
4.10	Cleaning or replacing the lamps in the side section	66
4.11	Cleaning or replacing lamps in the canopy.....	67
4.12	Cleaning or replacing the low-pressure lamps in the shoulder tanner	68
4.13	Cleaning the filters in the base.....	68
4.14	Cleaning the canopy filter mats.....	69
4.15	Cleaning filter mats in the shoulder tanner.....	69

4.16	Air conditioning: Empty the condensation tank and cleaning the filter	70
4.17	AQUA / AROMA system maintenance	73
4.17.1	Changing the AROMA canister	74
4.17.2	Replacing the AQUA SYSTEM canister	75
5	Technical data	76
5.1	Power, connection rating and noise level	76
5.2	Dimensions	77
5.3	Lamp sets.....	78
5.3.1	Prestige FUSION SPECTRA HYBRID.....	78
5.3.2	Prestige FUSION SPECTRA UV BLUE	79
5.4	Spare parts and accessories	80
6	Appendix	81
6.1	JK timer controls	81
6.2	Equivalence key range.....	81
6.2.1	Description of the equivalence keys for fluorescent lamps	82
7	Index.....	83



1 Safety instructions and warnings



To ensure safe operation of the device, it is necessary to read the following safety instructions and warnings carefully and comply with them.

These instructions should be retained for future use.

The safety instructions summarized here are repeated in the corresponding chapters, where necessary.

1.1 General

1.1.1 Definitions

Operator

Person who provides the devices described here to users on a commercial basis. The operator is responsible for the correct operation of the device as well as compliance with the maintenance intervals.

User

A person who uses the device at a commercial location.

Personnel

People who are responsible for the operation, cleaning and general maintenance work and who instruct the users in the operation of the devices.

Electrician

A person with suitable professional training, knowledge, experience and knowledge of the applicable regulations which enable them to identify and avoid the dangers which can arise from working with electricity.

Authorized, trained and qualified personnel

Qualified staff from an external company who have been trained and authorized by the manufacturer to undertake assembly and maintenance work on specific equipment.

1.1.2 Symbol explanation

The following types of safety notices are employed in these operating instructions:



 DANGER!



Type and source of hazard

This safety notice indicates the existence of a direct danger to body and life.

 DANGER!



Type and source of hazard

This safety notice warns of dangers to body and life which are caused by electricity.

 WARNING!



Type and source of hazard

This safety notice warns of flammable substances.

 WARNING!



Type and source of hazard

This safety notice warns of machine, material or environmental damage.



NOTE:

This symbol does not identify any safety notices, but provides additional information to better understand the processes.



1.2 Intended use

This unit serves the purpose of cosmetic tanning for one adult person with skin suitable for tanning. More detailed information can also be found on pages 12 and 32.

This device is intended only for commercial use and not for private use.

Some people are not permitted to use the device, see page 9.

The device may not be used by people with reduced physical, sensory or mental capabilities or who have insufficient experience and/or knowledge without supervision. A person responsible for their safety must ensure, either by supervision or instruction, that the device is used correctly and safely. If there is any doubt, use of the device by such categories of persons is to be forbidden!

The device may only be operated with the specified or equivalent lamps. The tanning times given in this instruction manual are valid only for the specified lamp set.

Any other use shall be considered improper. The manufacturer cannot be held liable for damage or injuries resulting from this. The operator bears the sole risk for this.

Proper use also includes compliance with the manufacturer's instructions and its operating and maintenance conditions. The unit may only be operated, maintained and repaired by trained professionals familiar with this unit and who have been informed of the dangers involved.

1.3 Foreseeable misuse

The following uses of the device are explicitly prohibited:

- The device may not be used by several people at the same time. The acrylic glass panel may otherwise break and cause injuries.
- People with a body weight of more than 135 kg may not use the device. The acrylic glass panel may otherwise break and cause injuries.
- Exceeding the specified tanning times may result in burns and long-term skin damage.
- When the device is in use no other people may remain in the cabin, in particular no children.
- While using the device no pets may be present in the cabin.
- People under 18 years of age may not use the device.

1.4 Tanning safety information

1.4.1 Prohibited usage



 DANGER!



UV radiation
 Danger of skin and eye injuries or skin diseases!
 - Please observe the following instructions.

The following people may not use the device:

- People under 18 years of age
- People who cannot tan
- People who cannot tan in the sun without risking a sunburn
- People who easily sunburn when in the sun
- People with acute sunburn
- People who repeatedly suffered from serious sunburn during childhood
- People with naturally red hair
- People with atypically discoloured areas of skin
- People who have or have had skin cancer
- People who suffer from an increased risk of skin cancer (e.g. cases of skin cancer in the family)
- People among whose closest relatives a melanoma has occurred
- People who are being medically treated for photosensitivity
- People taking photosensitivity causing medicine
- People with freckles and people who tend to develop freckles
- People with more than 16 moles on their body (2 mm diameter or larger)
- People with atypical moles (atypical moles are, for example, asymmetrical moles with a diameter greater than 5 mm, with varying pigmentation and irregular edges)
- Seek medical advice without fail if in doubt!

The following people may only use the device after consultation with their doctor:

- People with chronic illnesses, in particular those related to the skin
- People with illnesses of the immune system / auto-immune diseases
- People with collagenosis (e. g. lupus erythematoses, scleroderma)
- People suffering from rosacea (copper rose)
- People with spider veins (e. g. couperose, Osler's disease, spider nevi)
- People with low blood pressure, cardiovascular diseases
- People suffering from venous diseases
- People suffering from cancer
- People with fresh wounds following an operation or surgery



- People with tattoos or piercings which have not fully healed
- Pregnant women

Should there be any doubt with regard to compatibility, despite no known medical side effects, a test application of a maximum of 5 minutes should be initially carried out and the reactions observed. If no adverse reactions are found after 48 hours, normal application may be begun.

1.4.2 Important notes

All other people must observe the following instructions:

Danger of skin and eye injuries or skin diseases!

- The skin can become sunburnt when exposed to excessive radiation. Excessive, frequently repeated UV radiation exposure from natural sunlight or UV devices can result in premature ageing of the skin and an increased risk of skin tumours.
- Particular caution is advisable for individuals who are especially sensitive to UV radiation, and when certain medicaments or cosmetics are used. Seek medical advice without fail if in doubt!
- Seek medical advice if any unexpected consequences, such as itching, occur within 48 hours of the first tanning session.
- Increasing tanning requires increased exposure time (= radiation time) or after a certain degree of tanning has been achieved, increased tanning is not possible. However, the radiation time may not be extended as desired within the scope of the permissible radiation doses! Therefore, only a certain level of final tanning, which depends on the skin type, can be achieved without endangering your health.
- The tanning unit must never be used when the housing is broken or damaged, or the timer is defective!

Behaviour before, during and after a sunbath:

- During the tanning session no other people may remain in the cabin, in particular no children.
- Remove all jewellery (including piercings) before the tanning session.
- Remove cosmetics before tanning and do not use sun screen products.
- Do not use any products intended to accelerate tanning.
- UV light can cause irreversible skin or eye damage. The unprotected eye can become inflamed on the surface, and in certain cases the retina can be damaged by excessive radiation. Cataracts can form after numerous repeated tanning sessions. Use the UV-impermeable protective goggles provided (order no. 1027211-..). Contact lenses and sun glasses are no substitutes for protective glasses.
- Protect sensitive skin areas such as scars, tattoos and genitals before tanning.
- Observe the recommended tanning times.

- During a tanning session the quantity of radiation which results in the skin reddening (MED, minimum erythema dose) may not be exceeded. If reddened skin occurs around 16-24 hours after the tanning session you may not use the tanning device again for one week. After one week you can start again from the beginning with the first tanning session in accordance with the tanning table.
- The time between the first two sessions on the sunbed must be at least 48 hours! Do not take an additional sunbath on the same day.
- See a doctor if stubborn swelling, sores or pigmented moles form on the skin.





1.4.3 Skin type descriptions

 **DANGER!**







Burns and long-term damage!
 People with skin type I may not use the tanning device.
 The following applies to people with skin types II, III and IV:

- Observe the tanning times.
- Observe the safety instructions.



NOTE:
 The tanning times are only valid for the lamp set specified on the lamp set sticker.
 The tanning sessions should be at least 48 hours apart.
 The maximum dosage of 25 kJ/m² per year should not be exceeded.
 The maximum dosage is weighted according to NMSC.¹

Skin type I	Skin type II	Skin type III	Skin type IV
			
Sensitive skin	Light skin	Normal skin	Dark skin
Always/frequently burns	Usually burns	Sometimes burns	Rarely burns
Tolerates only a small amount of natural sun.	Tolerates approx. 10-20 min. of natural sun.	Tolerates approx. 20-30 min. of natural sun.	Tolerates approx. 40 min. of natural sun.

¹ NMSC: Non Melanoma Skin Cancer

1.4.4 Tanning times EN



NOTICE:

People with skin type I should not use the device.

- Observe the tanning times



Observe the national requirements!

The tanning dosage of 3 kJ/m² per programme of tanning sessions should not be exceeded.

The maximum tanning time must not exceed 33.

The tanning sessions must be at least 48 hours apart.

The maximum tanning minutes per year should not exceed 833 minutes.

Prestige FUSION SPECTRA HYBRID:

- UV low-pressure lamps
ERGOLINE TREND ADVANCED 80-200 EP104 160W R 1511231-..
- Low-pressure lamps SMARTSUN+ R 27 160W 1511232-..
- Low-pressure lamps SMARTSUN 35 8W 1512461-..

Prestige FUSION SPECTRA UV BLUE:

- UV low-pressure lamps
ERGOLINE TREND ADVANCED 80-200 160W EP104 R 1511231-..
- Low-pressure lamps
ERGOLINE BLUE 80-200 160W EP201 R 1512082-..
- Low-pressure lamps
ERGOLINE TREND E12 8W 1512462-..

Number of tanning sessions	Skin type I [min]	Skin type II [min]	Skin type III [min]	Skin type IV [min]
1	–	5	5	5
2	–	11	11	11
3	–	13	13	13
4	–	13	13	13
5	–	16	16	16
6	–	16	16	16
7	–	20	20	20
8	–	22	22	22
9	–	25	25	25
10	–	25	25	25



NOTICE:

According to standard EN 60335-2-27:2013 the tanning table is not depending on skin types.

Identical tanning times are valid for all skin types, with the exception of skin type I.



1.5 Safety instructions and warnings

1.5.1 Operator's obligations

As the operator you are responsible for providing clear operating, cleaning and maintenance instructions and ensuring the intended use and the proper operation of the unit by means of training and instruction for the personnel.

Your operating instructions must enable the safe use and safe operation of the unit and take into account the characteristics and expertise of your company and also the national work safety and environmental protection regulations (within the European Union, the EU directive 89/391/EEC).

1.5.2 Personnel training

As the operator you are obliged to train your personnel and instruct them in the established legal and accident prevention regulations. Ensure that your personnel have understood and observe these operating instructions. This applies in particular to the

- information in 'Intended use' and 'Foreseeable misuse'
 - safety instructions in the 'Operation' chapter
 - operating instructions
 - cleaning and maintenance instructions
- Please make the instructions and additional information from the manufacturer available to the personnel at their workplace.
 - Regularly check your personnel's safety consciousness and awareness of the risks, taking into account your operating instructions.
 - Please ensure that the cleaning intervals are complied with, in particular cleaning after every tanning session.
 - Please ensure that your personnel provide your customers with appropriate advice, in particular regarding tanning times, possible risks and the operation of the device.
 - People under 18 may not use the device. Please instruct your personnel to check the customer's identification in the event of doubt.

1.5.3 Scope of delivery

Information regarding the scope of delivery is contained in the 'Description' chapter on page 29.

1.5.4 Transport, assembly and setup

The device is delivered by a specialist company and assembled and set up by the manufacturer's own service personnel or by an authorized service company.



As an operator you are responsible for complying with the on-site ventilation and electrical requirements at the setup location, see page 15.

Assembly

DANGER!



Personal danger due to electric shock or burns!

- The assembly and electrical connection must comply with the national regulations.
- The on-site electrical installation must be fitted with an easily accessible all-pole isolating device (master switch), complying with overvoltage category III. This means that each pole must have a contact opening width complying with the conditions of overvoltage category III for full isolation.
- If the connection is established via a plug-in connection then the connection system according to EN 60309 must be utilized.
- Assembly, installation, upgrading or repair of the device may only be carried out by specially trained and authorized personnel.

Information regarding the disassembly and assembly of the device is available in the separate assembly instructions. These assembly instructions are intended solely for use by the manufacturer's service personnel or by qualified specialists authorized by the manufacturer.

Ventilation

WARNING!



Risk of overheating due to air flow problems!

Operating faults possible.

- Do not change, obstruct or block the air inflow and outflow area to the unit or make any unauthorized changes to the unit. The manufacturer shall bear no liability for damage or injuries resulting from such actions.
- Observe the ventilation system data.
- Do not set up and operate the device on the transport pallet!

You can obtain data regarding the air supply and ventilation from the customer service department (see page 2).



Setup location

 **WARNING!**



Salty air! Contaminated air!

Device damage due to corrosion of the housing and electrical components.

- Do not set up the unit at a swimming pool.
- Do not operate the device in locations with aggressive environmental conditions (e.g. air containing chlorine).

Damage to unit possible!

Where there are great differences in temperature between the transport route and the installation site the unit may not be put into operation immediately after being set up.

- Wait at least 2 hours before connecting the unit to the power supply.

Risk of overheating due to air flow problems!

Operating faults possible.

- Do not change, obstruct or block the air inflow and outflow area to the unit or make any unauthorized changes to the unit. The manufacturer shall bear no liability for damage or injuries resulting from such actions.
- Observe the ventilation system data.
- Do not set up and operate the device on the transport pallet!

Environmental conditions

Possible damage to the unit!

The unit is not to be used outdoors.

Keep the unit away from open flames or sources of ignition.

- Optimum ambient temperature: Between +15°C and +32°C
- Storage temperature: Between -15 °C and +60 °C

Adaptation of the unit is required for operating altitudes greater than 2000 m above sea level in order to guarantee trouble-free operation.

The device is not suitable for operation in mobile facilities (ships, buses, trains). Adaptation of the unit is required in order to guarantee trouble-free operation when used in mobile facilities.

Please contact the Customer service department without fail before putting the unit into operation - see page 2.

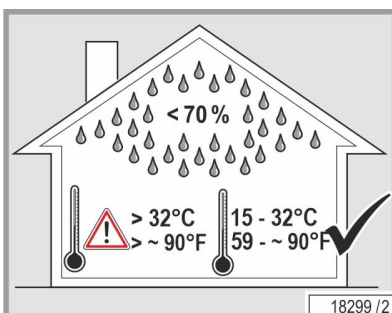
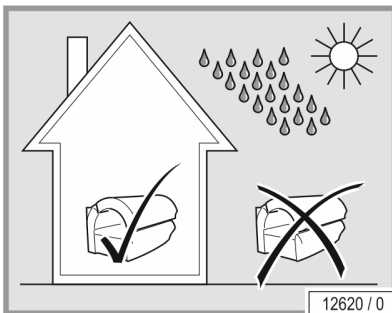

1.5.5 Commissioning

 DANGER!



Damaged mains power cable!

Danger to persons through electric shock or burns.

- Only the manufacturer or specialist companies are permitted to replace the mains power cable.



Initial commissioning will be undertaken by the manufacturer's own service personnel or by an authorized service company. The device will be handed over ready for use.

If the device has not been used for a longer period of time, then it must first be inspected by our customer service department or by another authorized company before being put back into operation again.

The device is operated with an external time-control unit.

A time control unit must be attached so that the device automatically switches off at the latest after <110 % of the selected running time even if the controller fails. The device running time must be secured with a timer control that complies with the standard EN 60335-2-27).

Dependent on the local power supply company, the devices can transmit interference to the power system of the building that impair the audio-frequency remote control system used by the power supply company. This can, for example, interfere with the function of night-storage heaters.

If faults occur due to the operation of the devices, then the operator is responsible for the installation of an audio frequency blocking device in the building electrical installation. Please contact your electrician. The electrician is familiar with the technical connection conditions of your local utility company so that the audio-frequency blocking device can be matched to the power system of your power supply company.

The unit can be operated temporarily or continuously with a stand-alone or non-mains-synchronous power supply (e.g. microgrid or back-up system). However, you must contact the customer service department before putting the unit into operation in this way – see page 2.

1.5.6 Operation and maintenance

Error-free operation, maintenance and service are required in order to ensure that the health and safety of the users is not endangered during operation and to ensure that the device is in a fault-free operating condition.

Please observe the information and recommendations provided in these operating instructions. Please ensure that the intervals for the inspection, maintenance and service are complied with. Please ensure that the lamps are replaced after the specified usage time.

Unauthorized modifications and changes to the device and its control unit are prohibited. Failure to comply with this invalidates the operating licence!

To avoid hazards, the device must not be used if the mains power cable is damaged. A damaged mains power cable must be replaced by



the manufacturer or their customer services, or by trained and qualified specialist personnel.



NOTE:

If a fire is suspected, immediately disconnect the power supply as long as this is safely possible. Continue to observe all regulations required by law, public authorities and employer's liability insurance associations, which remain unaffected by the aforementioned instructions.

1.5.7 Decommissioning

The device must be disconnected from the power supply in order to temporarily or permanently decommission it.

You must abide by the legal disposal requirements when permanently decommissioning the device.

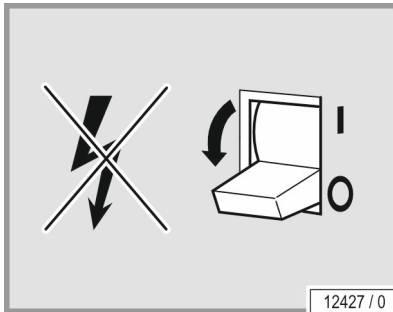

1.5.8 Storage

Store the devices in a dry location with a stable temperature. Once the device has cooled off, pack it in plastic wrapping to protect it against scratches.

- Storage temperature: Between -15 °C and +60 °C

CAUTION!



Inflammable refrigerant in the air conditioning system!

Leaking refrigerant can lead to fires or explosions.

- Avoid sources of ignition! Fire, naked flames and smoking are prohibited.
 - Only ever store in rooms without permanent sources of ignition, e.g. naked flames, functioning gas appliances or electric heaters.
-

1.5.9 Disposal

Environmental regulations – disposal of lamps and batteries

Lamps contain fluorescent materials and other waste containing mercury. Batteries contain heavy metal compounds.

Within the European Union the national implementation of the Waste Framework Directive 2018/851/EG applies. According to the national waste disposal laws and in accordance with the municipal waste regulations, proof must be provided of the proper disposal of lamps and batteries.

Your local sales agency will be happy to assist you with the disposal of lamps and batteries:

- Inform your local agency of the number of lamps and batteries by telephone or in writing.

The agency will then provide you with the name of a free delivery point for your lamps or will take care, in conjunction with a disposal company, of the collection and proper disposal of the lamps. This service is available for a fee. Outside Germany, the respective national legislation applies. Please contact your local sales agency.

Packaging

All packaging consists of 100 % recyclable materials. Packaging brought into circulation by the JK Corporate Group that is no longer required can be returned to the JK Corporate Group. Your partner agency or dealer will be happy to advise.

Disposal of old units

The unit has been manufactured using recyclable materials. The JK Corporate Group will provide you with information on the content or potential hazards of the materials used.

The manufacturer is obliged to take back and dispose of certain electrical and electronic components in accordance with the 2012/19/EC Directive.

The components and units are labelled with the following symbol:

The unit will, if requested, be properly disposed of by the JK Corporate Group. This service is available free of charge. Your partner agency or dealer will be happy to advise.

Registration numbers

Companies within the JK Corporate Group are registered as manufacturers in Germany and accept all obligations in respect of the German Electrical and Electronic Equipment Act.

Registry number JK-International GmbH, Division JK-Licht GmbH (lamps):

WEEE-DE 61515020

Registry number JK-Products GmbH (Devices):

WEEE-DE 62655951

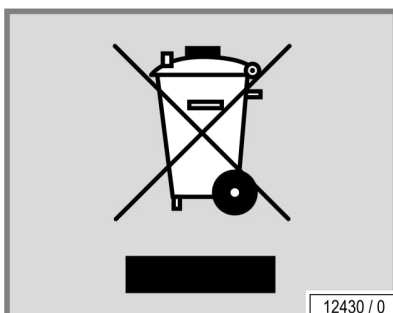
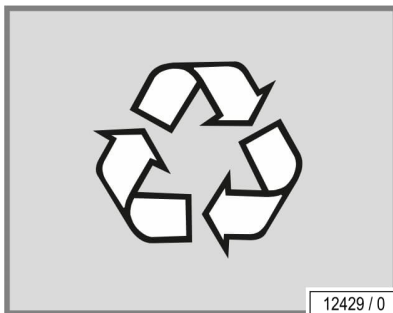



1.5.10 Directives

See the included EC Declaration of Conformity.

1.5.11 Export

We emphasize that these units are only intended for the European market and must not be exported to or operated in other countries e.g. the USA or Canada! The manufacturer does not accept any liability in the event of non-observance! We explicitly emphasize that non-compliance may result in high liability risks for the exporter and/or the operator.

1.5.12 Own music

If a smartphone is used privately during the application, this does not constitute a public performance within the meaning of the Copyright Act, so that the studio operator is not obliged to report or pay fees to the awarding body for commercial performance rights.

For the public use of music files, the same regulations apply as for other sources of music: As the owner/operator of the studio, you are only permitted to play original audio files on your premises and/or in the "MP3 music module" included in JK International GmbH units if you have acquired the performance rights required for this purpose. You can obtain these rights from the organisation responsible for granting commercial performance rights in your country (in Germany: GEMA/GVL).

Copyright-protected audio files and the tracks included on these sound storage media may not be converted into MP3 format and/or stored on HDDs, audio CDs, MCs, audio DVDs, etc., if the conversion/storage process uses software that invalidates or bypasses the copyright protection included on the sound or data storage media.

You must be ready at any time to prove your granting of stage rights by presentation of the appropriate stage rights certificate when requested by a representative or another controlling body of the responsible organisation.

Provided that you have complied with all the information above and acquired the rights required for using the "MP3 music module", you can also convert your original audio files into the MP3 format required for the playback device. However, only one copy (duplicate or copy converted into MP3 format) may be produced of each legally acquired audio file. The source media (original sound storage media) must be kept and may not be used simultaneously.



NOTE:

Recorded SD cards that are supplied with a JK audio system as accessories are also subject to payment for commercial use if they contain PRS for Music-liable content.

1.5.13 Technical modifications

The device has been constructed in accordance with the current state of the art and the applicable safety regulations. The illustrations and specifications in these operation instructions are subject to technical modifications which are required in order to improve the device.

Unauthorized modifications and changes to the device and its control unit are prohibited. Failure to comply with this invalidates the EC conformity!

Please use only original spare parts. Failure to comply with this invalidates the EC conformity!



1.6 Signs and stickers on the unit

Danger area warning signs and important information about components are attached to the unit. The signs shown below are examples. Ensure that the warning signs are always clearly recognisable and legible. Any missing warning signs or stickers must be replaced.

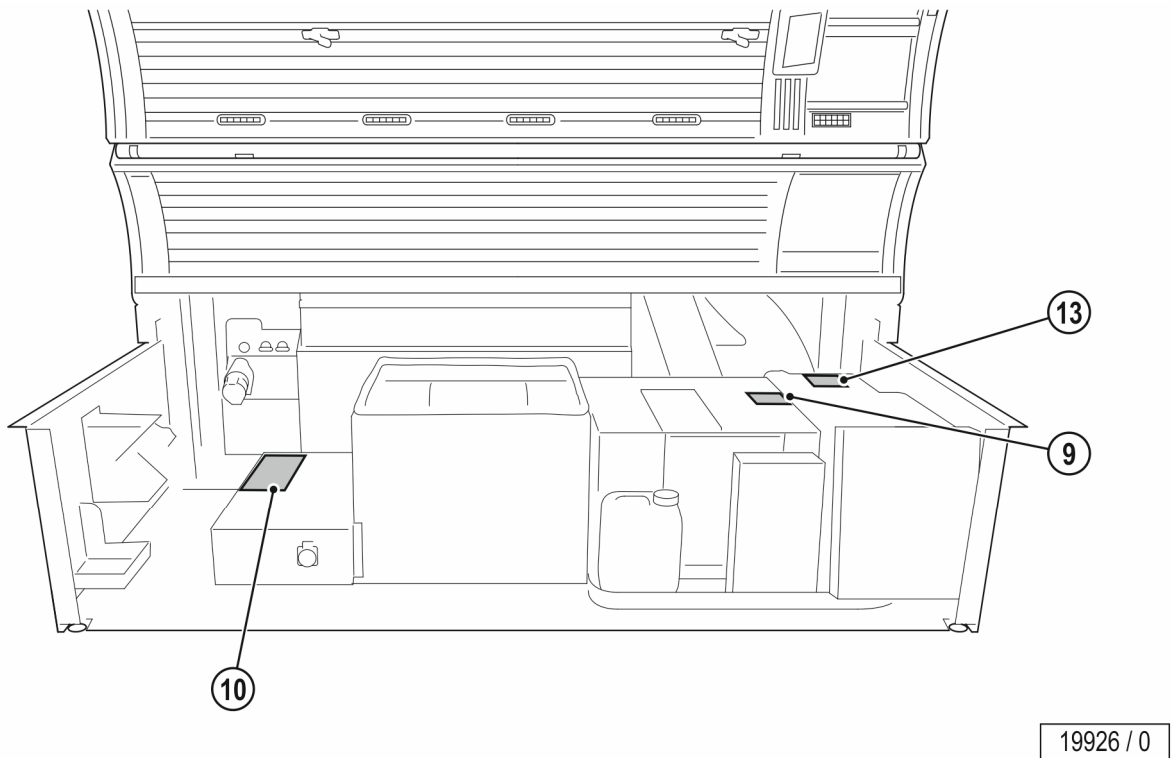
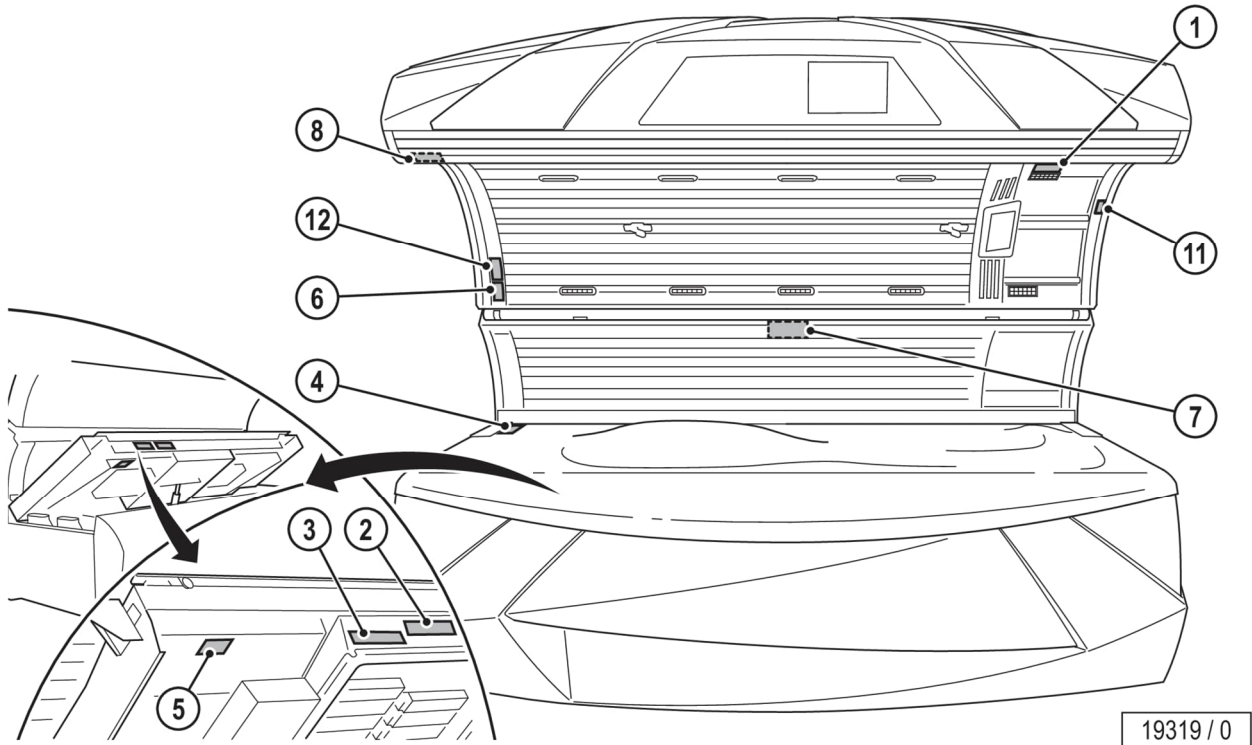



1: EU warning sticker (1012638-..)



This sticker also includes the language form 1504231-.. (see accessories Technical Documentation).

2: 'No export USA/Canada' sticker (84829-..)

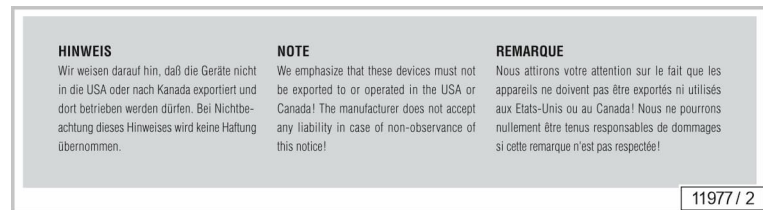

The sticker is mounted on the bottom edge at the front of the bed base.

3: 'Only use original spare parts' sticker (801026-..)

The sticker is mounted on the bottom edge at the front of the bed base.



4: Lamp set sticker

				Ergoline ESPERT 770-S DYNAMIC POWER	
①	19x			Ergoline TREND 80-200 W ES	1504250-
②	8x			Ergoline TREND 80-200 W ES	1504250-
③	22x			Ergoline TREND 80-200 W ES	1504250-
④	3x	4x	2x	Ergoline ULTRA 320W	150445
		2x	2x	ULTRA PERFORMANCE 800	15007043-
⑤	-	-	-	ULTRA PERFORMANCE 800	1504264-
				Ergoline TREND 8 W ES	1503060-
⑥		2x		Ergoline ULTRA 180 W	1500384-
			2x	ULTRA PERFORMANCE 800	15007043-
			2x	ULTRA PERFORMANCE	15007160-
JK-Products GmbH / GERMANY				1003066-01	

12846 / 0

The precise details of the required lamps are available in the separate appendix.

5: AQUA FRESH sticker (800839-...)

The sticker is mounted on the bottom of the bed base.

6: Maintenance instruction sticker (800701-...)

ACHTUNG!
 Dieses Gerät muß regelmäßig nach Hersteller-
 vorschrift technisch gewartet bzw. über-
 prüft werden, um jegliche Gefahr körperlicher
 Schäden vollständig auszuschließen.
 Plakettenbeschriftung = "Geräteproduktion ...
 Quartal/Jahr"

ATTENTION!
 This sunbed must be checked and serviced
 at regular intervals in accordance with the
 manufacturer's specifications in order to
 rule out entirely any risk of physical injury.
 Label wording = "Date of manufacture ...
 quarter/year"

12225 / 1

The sticker is mounted at the foot end on the inside of the canopy.

7: Sticker

8: Type plate

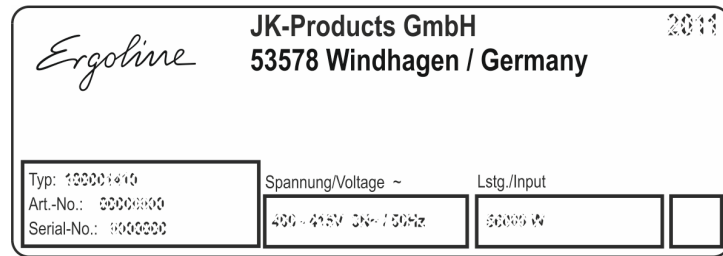

11991 / 2

The name plate is attached to the interior side of the canopy. It contains important information for identifying the device (e. g. the serial number = Serial-No.).

Stickers 9,10 and 13 are mounted beneath the bed base.

9: Air conditioning sticker (1002243-..)

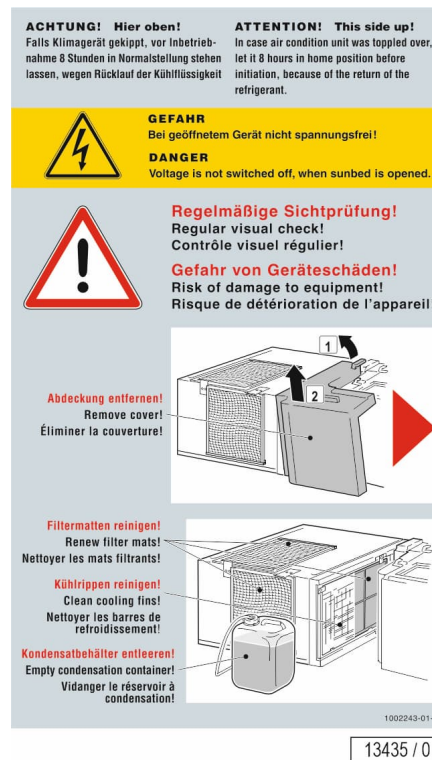

The sticker is mounted on the air conditioning.

10: Controller connections sticker (1511737-..)

The sticker is mounted on the controller support.



11: Emergency off sticker (1512131-..)



The sticker is mounted at the head end on the inside of the canopy.

This sticker also includes the language form 1018688-.. (see Technical Documentation folder).

12: Sticker Blue LED risk group 2 (1020652- ..)



The sticker is mounted at the foot end on the inside of the canopy.

13: UVC sticker

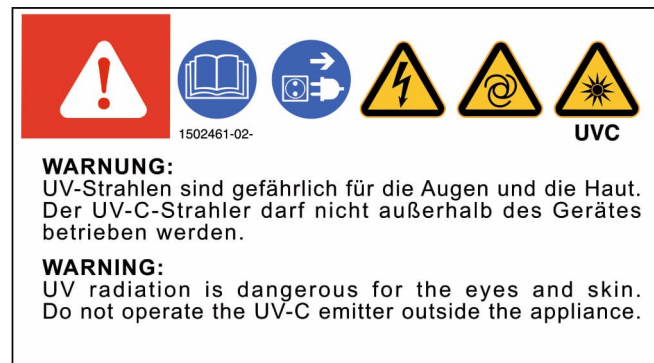

19920 / 0

ESD (Electrostatic discharge) - sensitive components sticker
(85662-...)

This sticker is mounted in several places in the device.



1.7 Preclusion of damage

Insofar as the customer asserts any rights related to a defect in the unit based on the legal warranty and/or guarantee, the following shall apply:

The warranty and guarantee do not cover wear parts such as low-pressure lamps (tubes) or consumables (aroma) or acrylic glass panels.

Should the product contain faults, JK-International is entitled and obligated to repair or replace the product at its own discretion. Where it is not possible to repair or replace the product, the customer may withdraw from the purchase agreement or reduce the purchase price by a suitable amount.

The warranty period is two years from delivery or from acceptance, if an acceptance process is required. This does not affect the rights of the customer under the existing warranty with regard to any claims that the customer might have in accordance with the contract of purchase.

1.8 Exclusion of liability

Regardless of the legal grounds, liability of the JK Group shall be excluded if damage can be attributed to one or more of the following causes:

- improper use of the unit;
- improper assembly, commissioning, operation and maintenance of the unit;
- operating the unit with faulty safety equipment or improperly attached or non-functional safety and protective equipment including warning signs;
- not complying with the information in the operating instructions regarding transport, storage, setup, commissioning, operation and maintenance;
- the use of untrained personnel;
- unauthorized changes to the unit or the control unit;
- inadequate monitoring of parts subject to wear;
- repairs carried out improperly;
- the use of non-original spare parts;
- emergencies and disasters resulting from the influence of foreign materials or force majeure.

2 Description



2.1 Scope of delivery

- Tanning device
- LED SHOULDER TAN with sound system
- Service kit: contains Allen key and suction cup
- Air conditioning system
- Connecting lead
- Protective goggles
- Mastercard NFC (studio operator)
- Low-pressure lamps
- Technical documentation (operating instructions, error code brochures and PROFESSIONAL SETUP MANAGER PLUS and other documents)

2.1.1 Options

- REMOTE SERVICE
- pure air
- Central exhaust air socket

2.2 Equipment

Device equipment varies depending on the model.

In this description, all standard and optional components/functions are taken into account which must be observed during operation and/or when performing maintenance.

The control panel also differs according to the varying equipment: Only those buttons are illuminated from behind that can be operated, i.e. the corresponding function must be included in the device's equipment.

2.3 Unit description

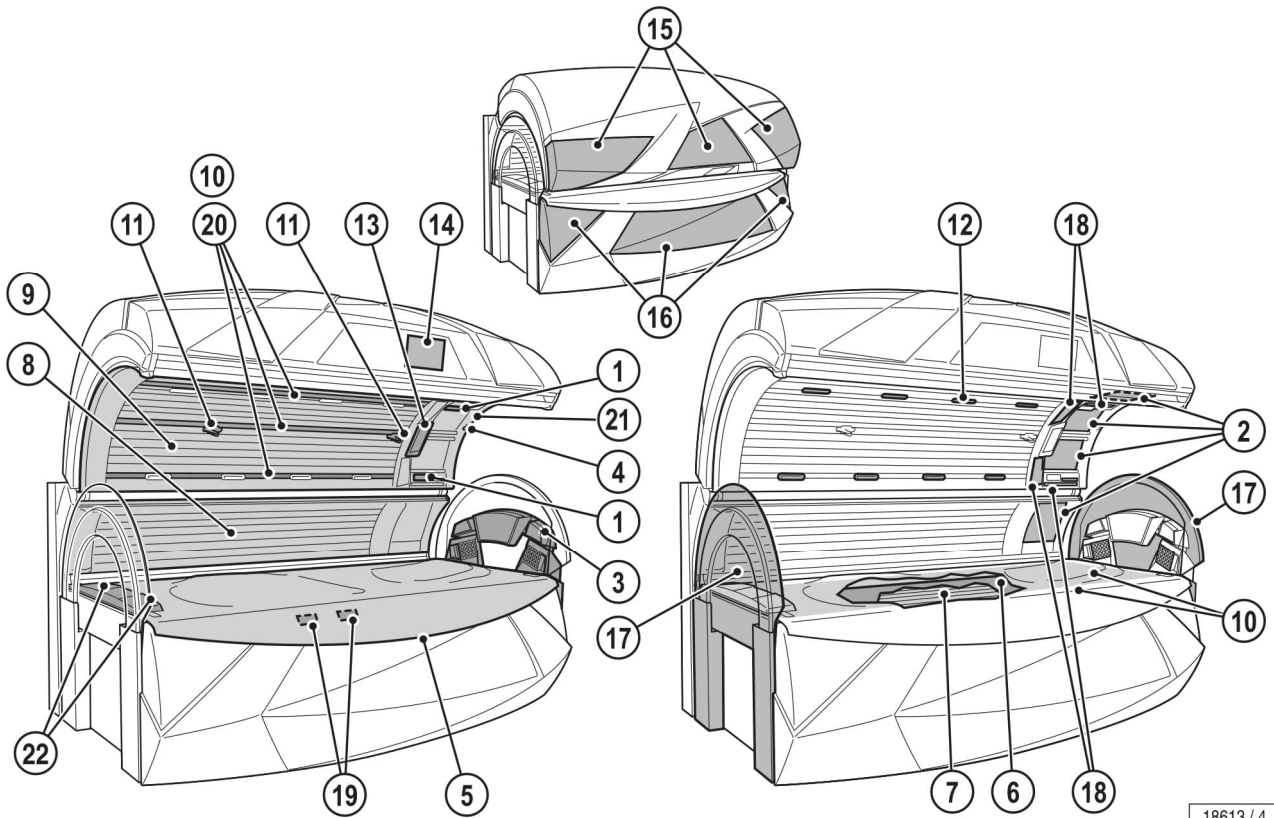

18613 / 4

1. Adjustable air nozzles – Facial cooling/AROMA SYSTEM
2. Facial tanner (UV LED board SPECTRA + low-pressure lamps)
3. LED SHOULDER TAN with sound system, including Bluetooth® and wireless charging station for smartphones
4. EMERGENCY OFF button
5. Acrylic glass panel base
6. Partition
7. Low-pressure lamps, base
8. Low-pressure lamps, side section
9. Low-pressure lamps, canopy
10. Interior lighting (LEDs)
11. Nozzles AQUA / AROMA SYSTEM
12. Body cooling air nozzles
13. INTERIOR DISPLAY
14. PROFESSIONAL SETUP MANAGER PLUS with SELECTABLE TANNING PROGRAMS
15. Decorative lighting, canopy (LEDs)
16. Decorative lighting, front panel (LEDs)
17. Enclosed tanning tunnel
18. FUSION LIGHT (red & blue) face + neckline
19. Service Light (only with opened bed base)
20. FUSION LIGHT (red & blue) body
21. Microphone ELECTRONIC VOICE ASSISTANT (E.V.A.)
22. Body cooling air nozzles at feet end (optional)

2.4 Accessories (optional)

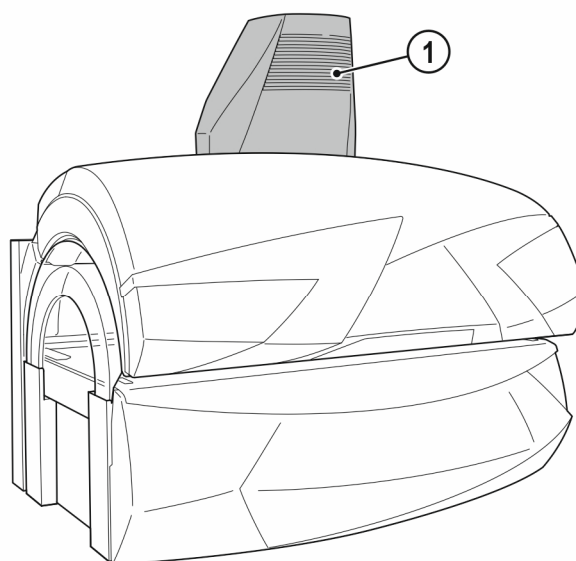

18859 / 1

1. Central exhaust air socket (optional)

2.5 Functional description

The primary technical components of a solarium are an artificial source of UV radiation and a mechanical structure with a defined active surface.

In the Prestige Fusion SPECTRA, the UV spectrum is generated by low-pressure lamps and UV LEDs and complemented by special red light (Beauty Light) and blue light (Activating Light).

There is choice of two lamp configurations:

Hybrid: The combination of UV tubes and smartsun tubes provides a particularly gentle tanning experience.

UV Blue: Through the special UV tubes an especially intense body tanning experience is generated.

Dynamic, electronic ballasts permanently guarantee 100% performance on the body.

pure air

Ergoline's top-of-the-range models can optionally be fitted with pure air for especially clean air. Based on UVC technology used in the medical field, pure air directly neutralises viruses and micro-organisms within the air current of the 3-zone ventilation system. Instead of simply catching micro-organisms such as bacteria or fungi in a filter, where they would be able to multiply, UVC completely deactivates them. For pure, clean air and laid-back tanning experience.

3 Operation



3.1 User safety information

 DANGER!



UV radiation

Danger of skin and eye injuries or skin diseases!

- Please observe the safety instructions and warnings in chapter 1.

Danger of hearing damage!

Using earphones or headphones at high volume can result in permanent hearing damage.

- Do not set the volume too high.

3.2 Tanning - but correctly!

A few things need to be noted in order to obtain maximum enjoyment from a tanning unit. Here are some answers to frequently asked questions.

Make-up on the sunbed?

A wide variety of materials is found in cosmetics. Whether these are emulsifiers, greases, or fragrances – in conjunction with UV radiation, these can cause skin allergy reactions.

For this reason, always use cosmetics that have been specially developed for use in tanning booths.

So, this to-do list is a must before using a tanning unit: Remove all make-up. This is essential. Make-up clogs the pores in the face. The UV light from a tanning unit re-opens these clogged pores so that not only does the light penetrate the skin, but also the allergenic components of the make-up.

A further negative consequence of make-up is that the appearance of the skin deteriorates irreversibly over a period of time. However good decent make-up looks - in conjunction with UV light, it causes more harm than good. Therefore: Remove all make-up before a session on your sunbed - it will be much better applied afterwards.

Showering after leaving the sunbed?

The browning is in the skin, not on it. Therefore you cannot wash it off. Treat your skin to a moisturizing cream after showering.

Are medications and the sunbed compatible?

It is known that some medicaments increase the skin's sensitivity to UV light. This probability is particularly high with antibiotics, sulphamides, psychiatric drugs, tranquillizers, anti-diabetes treatments and diuretics. Sun creams which contain psorale or kumarin also increase skin sensitivity. If you are in any doubt, first ask your doctor - then you can enjoy the sun at no risk.

Contact lenses on the sunbed?

The answer is: Yes! Like any other tanning unit user, contact lens wearers should also wear special protective goggles which protect the eyes against UV radiation. To guarantee better protection, wearers of spectacles and contact lenses can ask their optician for exchange contact lenses with UV protection. The UV-A and UV-B filters built into exchange contact lenses will protect the cornea and the internal parts of the eye against almost 100 % of the energy in UV radiation.

This will benefit tanning unit users not only in the open air, but on the tanning unit itself. You can wear these contact lenses on the tanning unit without any restrictions. For more information, ask your optician or optometrist.



3.3 Operating overview

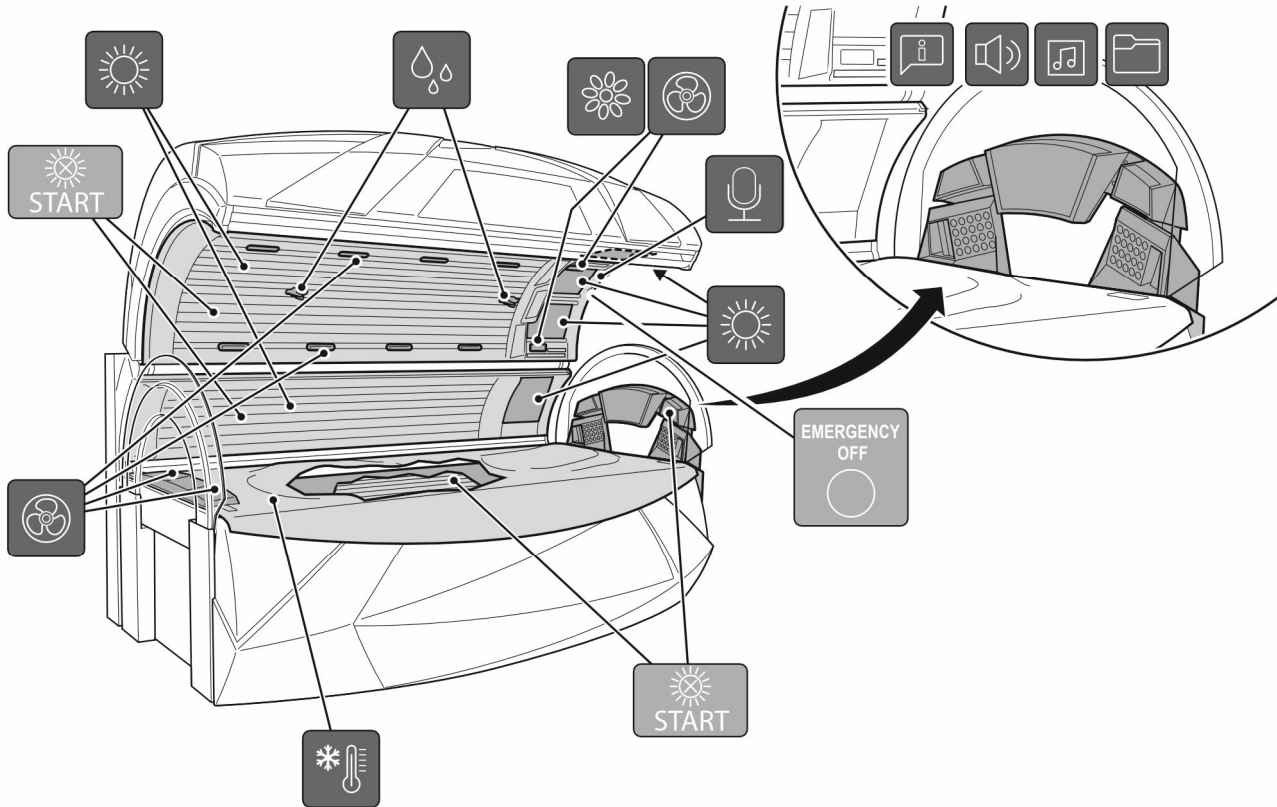

18614 / 3

3.3.1 PROFESSIONAL SETUP MANAGER PLUS

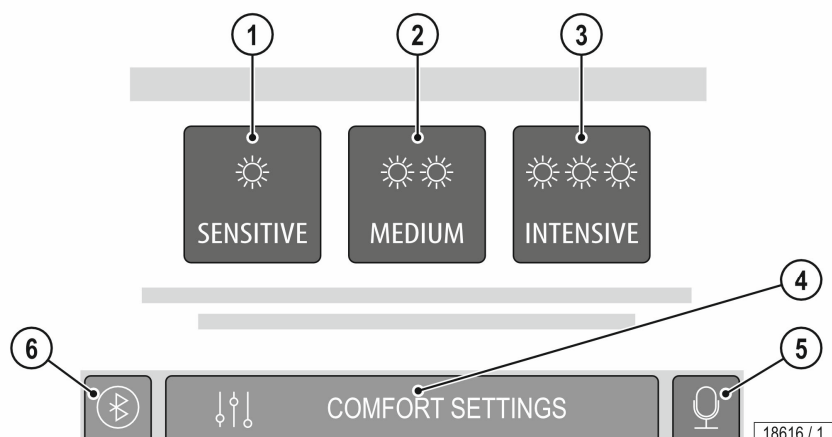

1. Application type: SENSITIVE
2. Application type: MEDIUM
3. Application type: INTENSIVE
4. Setup (comfort settings)
5. Voice control E.V.A. (optional)
6. Bluetooth® Connect (Audio System coupling)



NOTE:

If video option is activated:

In order to interrupt or end the video, briefly touch the PROFESSIONAL SETUP MANAGER PLUS.

More information on the Video Option can be found in the PROFESSIONAL SETUP MANAGER PLUS (order no. 1020179-..).

3.3.2 Navigation

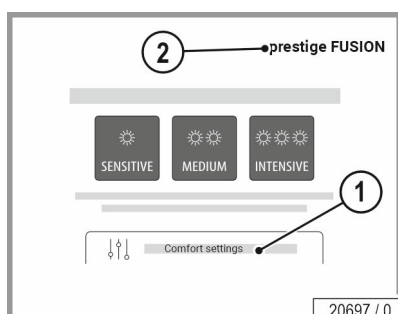

Before starting the device, the most important settings can be selected in advance in PROFESSIONAL SETUP MANAGER PLUS (order no. 1020179-..).

The user can select the application type before tanning starts. Further information on the application types: see chapter 3.5 on page 40.

The user profile can be used to select and save a number of other individual functions before the device is started.

All functions can be reached via the comfort settings (Item 1).



NOTE:

Press the Prestige SPECTRA logo (Item 2) to open 'PROFESSIONAL SETUP MANAGER PLUS'.







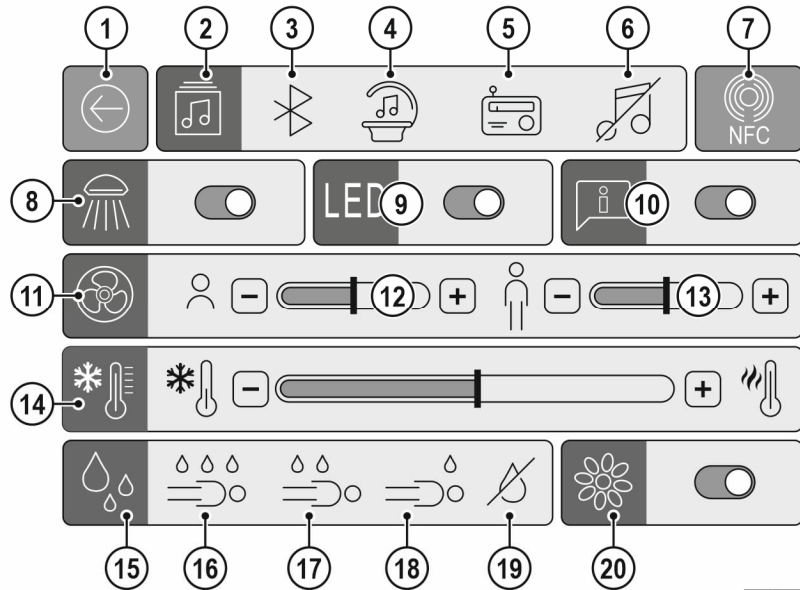



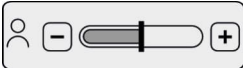
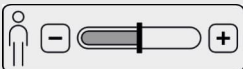

3.4 Functions

PROFESSIONAL SETUP MANAGER PLUS – User profile

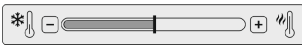

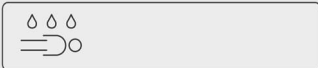
18901 / 1

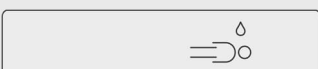
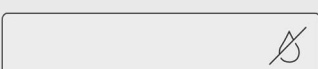
Icon selection / Key sequence	Description / Display	Information
1	Back arrow: touching the arrow takes you back to the previous interface from any function; touching the arrow several times takes you to the standard display	Back to the standard display
2	Selection of the audio sources	
3	Bluetooth® Connect	Activate by touching.
4	Internal music selection Music folder	Activate by touching.
5	Studio music channel	Activate by touching.
6	Audio sources OFF	Activate by touching.
7	NFC	Activate by touching. Saves the settings on the NFC medium.
8	Facial tanner SPECTRA (ON / OFF)	Moving the slider switches the function on or off.
9	LED (ON / OFF), FUSION LIGHT LED	Moving the slider switches the function on or off.

Icon selection / Key sequence	Description / Display	Information
10 	VOICE GUIDE (ON / OFF)	Moving the slider switches the function on or off.
11 	Fan (face/body fan)	The fans for the face and body can be adjusted separately. If the user does not change anything, the fan is automatically adjusted to the temperature.
12 	Face fan	
13 	Body fan	
14 	Climatronic	The Climatronic function can be used to increase or decrease the fan temperatures separately.
	Climatronic	Moving the slider enables the Climatronic to be regulated in three levels.
15 	AQUA FRESH selection	Can be adjusted separately for the head and body area.
16 	AQUA FRESH head and body nozzles	Activate by touching.
17 	AQUA FRESH body nozzles	Activate by touching.
18 	AQUA FRESH head nozzles	Activate by touching.
19 	AQUA FRESH: OFF	Activate by touching.
20 	AROMA	Moving the slider switches the function on or off.



NOTE:
All active functions are indicated in blue.

INTERIOR DISPLAY in standby



NOTICE:
If no application type is selected before the session, the user may select the desired tanning program in the INTERIOR DISPLAY.

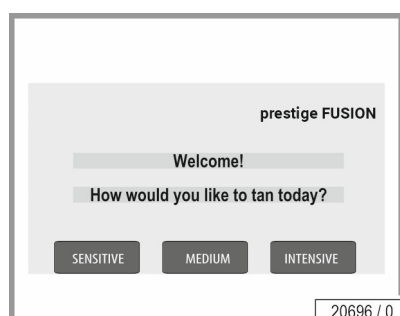

Further information on the application types:
see chapter 3.5 on page 40.







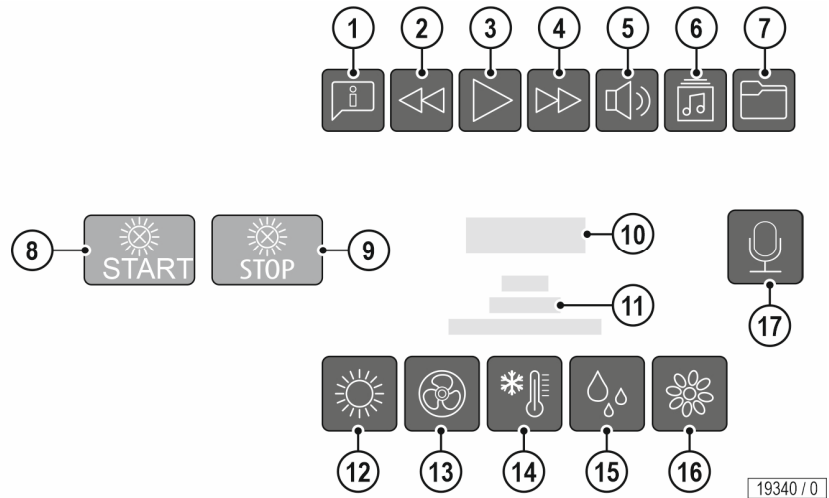





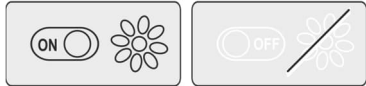

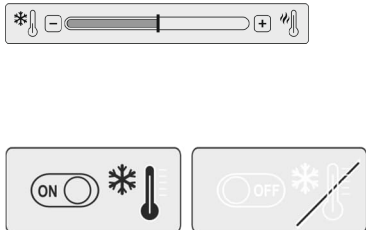

3.4.1 Navigation

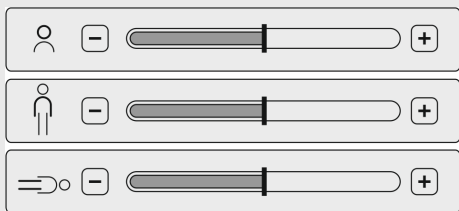
INTERIOR DISPLAY



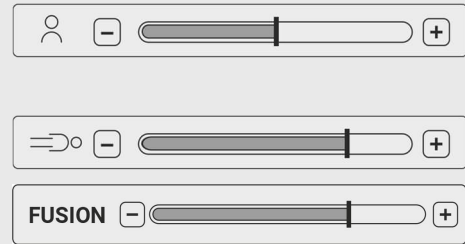



1. VOICE GUIDE pictogram
2. Audio back pictogram
3. Audio pause/play pictogram
4. Audio next pictogram
5. Volume pictogram
6. Audio source pictogram
7. Music folder pictogram
8. START pictogram
9. STOP pictogram
10. Display - Tanning time
11. Display - Track title
12. Application type selection pictogram
13. Face/body fan pictogram
14. Climatronic pictogram
15. AQUA FRESH pictogram
16. AROMA SYSTEM pictogram
17. Pictogram ELECTRONIC VOICE ASSISTANT (E.V.A.) (optional)

Icon selection / Description/display Key sequence	Information
 <p>AQUA FRESH</p> 	<p>AQUA FRESH for head and body AQUA FRESH for body AQUA FRESH for head AQUA FRESH OFF</p>
 <p>AROMA</p> 	<p>AROMA ON / OFF</p>
 <p>Audio sources selection</p> 	<p>Bluetooth® Internal music selection Studio channel selection Audio sources OFF</p>
 <p>Climatronic</p> 	<p>The Climatronic function can be used to increase or decrease the fan temperatures separately. Moving the slider enables the Climatronic to be regulated in three levels. Aircondition: Aircondition starts in the event of a Climatronic malfunction.</p>
 <p>Fan (face, body and foot fan)</p>  <p>Levels 0–9</p>	<p>The fans for the face, body and feet can be adjusted separately. If the user does not change anything, the fan is automatically adjusted to the temperature.</p>
 <p>VOICE GUIDE</p> 	<p>The VOICE GUIDE takes the user through the operation process. This function can be switched on and off at any time.</p>
 <p>Low-pressure lamps, FUSION LIGHT LED and facial tanner SPECTRA</p> 	<p>Switch off the facial tanner, press the minus button for 3 seconds adjust the facial tanner, levels 0–4 Adjust the low-pressure lamps, levels 1–3 Adjust FUSION LIGHT LED, levels 0–3</p>
 <p>Volume</p> 	<p>Levels 0 - 14</p>





Icon selection / Description/display Key sequence	Information
 <p>Music folder</p> 	<p>A maximum of 9 folders can be created. Folder names are limited to a maximum of 12 characters.</p>
 <p>EMERGENCY OFF</p> 	<p>When the EMERGENCY OFF button is pressed, the entire unit apart from the INTERIOR DISPLAY switches off. In this status, the display shows that the EMERGENCY OFF button has been operated.</p> <p>The edges of the EMERGENCY OFF button also flash red at the same time.</p> <p>The displays alternate with one another.</p> <p>The tanning time will keep running.</p> <p>The VOICE GUIDE indicates voice guidance.</p> <p>After being blocked for 2 seconds, the EMERGENCY OFF can be reversed again. The unit restarts in tanning mode.</p>

3.5 Selection of the application type (SELECTABLE TANNING PROGRAMS)

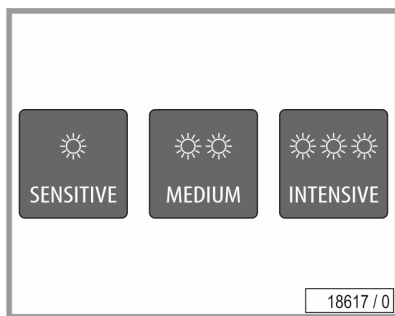

Before the session begins, the desired application type must be selected. There are 3 possible selections:

- **INTENSIVE:**
100% performance of the low-pressure lamps and the facial tanners, facial tanner level 3
- **MEDIUM:**
85% performance of the low-pressure lamps, facial tanner level 2
- **SENSITIVE:**
70% performance of the low-pressure lamps, facial tanner level 1

- Press the button for the desired type of application.



NOTE:

In each program, the FUSION LIGHT LED start with 100% performance. During the tanning session, the intensity of the facial tanner and the FUSION LIGHT LED can be changed at any time, or switched off completely. If no selection of the application type is carried out, the device starts up with the application type "INTENSIVE"

3.6 Start

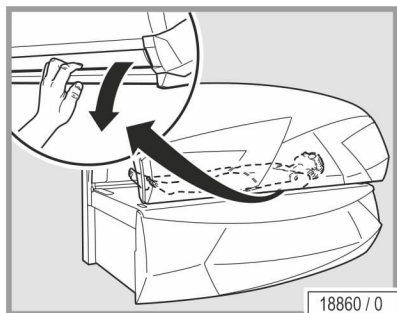

- Closing the canopy.
- Press the START/STOP button.

Upon starting the following functions are switched on:

- Lamps and LEDs
- Air conditioning system
- Body cooling
- Facial cooling
- Audio system
- VOICE GUIDE
- pure air (optional)





3.7 Coupling with Bluetooth® devices

 **DANGER!**



Danger of hearing damage!
 Listening to music at a high volume can result in permanent hearing damage.
 - Do not set the volume too high.

Users can pair their personal smartphone with the audio system. The devices must be paired before the tanning session starts.

The solarium and the user's personal smartphone can only be paired via Bluetooth®¹Connect. When using Bluetooth® Connect, the user can transfer their favourite music into the solarium wirelessly from their smartphone. Operation can be performed conveniently via the INTERIOR DISPLAY during the tanning session.



NOTE:

- Ergoline cannot guarantee full compatibility with all Bluetooth® devices.
- Before coupling a device with this system, read the user manual to find out more about the Bluetooth® compatibility.
- Make sure that the Bluetooth® function is activated on your device and that the device is visible for all other Bluetooth® devices.

Pairing with a Bluetooth® player

Activate the Bluetooth® function and search for Bluetooth® devices.

Activate the Bluetooth® function on the iPhone®:

iPhone®:

Settings → General → Bluetooth® → ON (search for units is started.)

Activate the Bluetooth® function on the Android® smartphone:

Android® smartphone:

Press the Bluetooth® symbol → SCAN (search for units is started.)



NOTE:

The tanning device can store a maximum of ten coupled Bluetooth® devices. In the event of recoupling the tanning device must first be deleted from the Bluetooth® device. The activation process must then be repeated.

¹ Communication system: Bluetooth® standard version 3.0, Version 2.1 and EDR; max. operating range: approx. 10 m; frequency range: 2.4 GHz range (2.4000 GHz - 2.4835 GHz); compatible Bluetooth profiles: A2DP, AVRCP; simultaneously supported devices (pairing): one device

Activate Bluetooth® Connect in PROFESSIONAL SETUP MANAGER

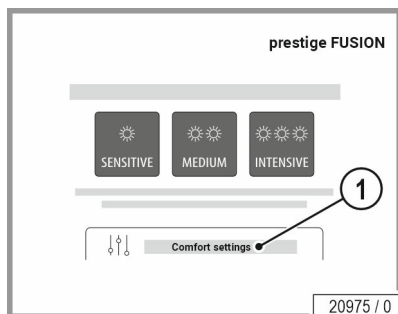

- Press comfort settings (1) in PROFESSIONAL SETUP MANAGER PLUS.

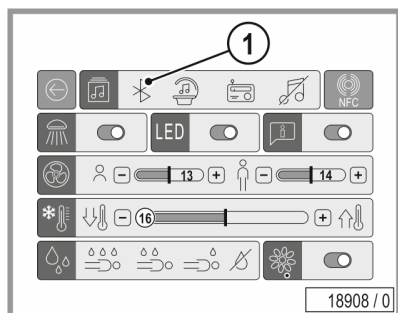

- Press the Bluetooth® icon (1) in the user profile.
- While the units are pairing, the Bluetooth® icon (1) lights up continuously in blue.



- Display in the smartphone.
- Select the Bluetooth® Connect name of the tanning device, e.g. ERGOLINE 01.

Successful Bluetooth® connection in the INTERIOR DISPLAY

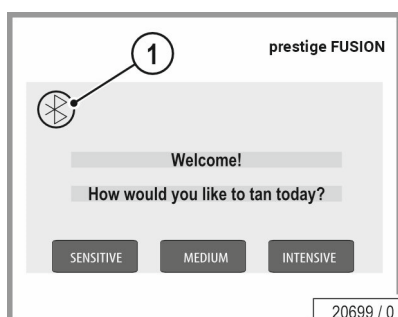

- Status display (1) when the units have been successfully paired.



NOTE:

When successfully paired, the Bluetooth® symbol (1) in the INTERIOR DISPLAY lights up blue continuously.

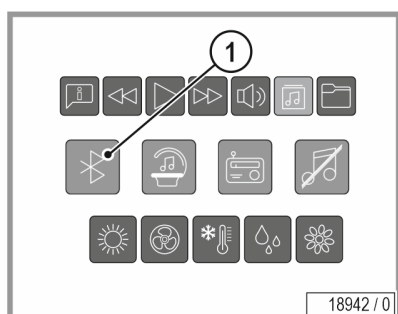

- Audio sources: Bluetooth® (1) selection in the INTERIOR DISPLAY.



NOTE:

Only audio sources that are activated in the PROFESSIONAL SETUP MANAGER PLUS can be selected.



3.8 Listening to music

 **DANGER!**



Danger of hearing damage!
Listening to music at a high volume can result in permanent hearing damage.

- Do not set the volume too high.

 **CAUTION!**



Possible heat damage to the smartphone.

- Do not place the smartphone directly in the area of radiation.

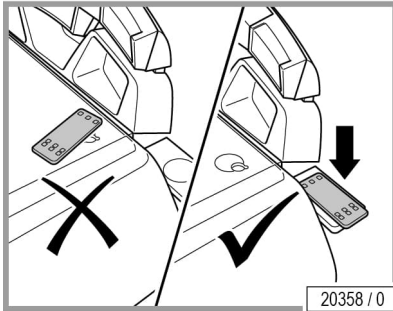

3.9 Smartphone Wireless Charging (optional)

Use this technology to charge your smartphone wirelessly. Simply place your Qi-compatible smartphone in the centre of the wireless charging station with the display facing upwards; it will start charging automatically. Straighten up the smartphone slightly if necessary until the charging function is activated.



NOTE:
Do not place any magnetic strips, chip cards (in passports, on credit cards, etc.) or metal objects onto the charging station. Some smartphone cases can impair the charging process.

3.10 Voice control ELECTRONIC VOICE ASSISTANT(E.V.A.) (optional)



The ELECTRONIC VOICE ASSISTANT (E.V.A.) allows the solarium to be operated using voice commands. The ELECTRONIC VOICE ASSISTANT can be activated with a click on the outer display. A video tutorial explains the operation. To start the voice control during the tanning session, speak: "EVA" or touch the touch display. The music volume and ventilation are then reduced for a few seconds. In this time, you can give the voice commands.



NOTE:

More information and updates are available on the global service homepage:
www.jk-globalservice.de.

Voice commands that are currently available:

Body, face and foot ventilation	Ventilation maximum Fan maximum	Ventilation minimum Fan minimum	Ventilation plus Fan plus	Ventilation minus Fan minus		
Body ventilation	Body ventilation maximum Body fan maximum	Body ventilation minimum Body fan minimum	Body ventilation plus Body fan plus	Body ventilation minus Body fan minus		
Face ventilation	Face ventilation maximum Face fan maximum	Face ventilation minimum Face fan minimum	Face ventilation plus Face fan plus	Face ventilation minus Face fan minus		
Foot ventilation	Foot ventilation maximum Foot fan maximum	Foot ventilation minimum Foot fan minimum	Foot ventilation plus Foot fan plus	Foot ventilation minus Foot fan minus		
Body lamps	Body lamps maximum Body tanner maximum	Body lamps minimum Body tanner minimum	Body lamps plus Body tanner plus	Body lamps minus Body tanner minus		
Face lamps	Face lamps maximum Facial tanner maximum	Face lamps minimum Facial tanner minimum	Face lamps plus Facial tanner plus	Face lamps minus Facial tanner minus	Face lamps plus Face lamps plus	Face lamps minus Face lamps minus
LED	LED on	LED off	LED maximum	LED minimum	LED plus	LED minus
Air conditioning	Air conditioning on	Air conditioning off				
Temperature	Temperature maximum	Temperature minimum	Temperature plus	Temperature minus		
AROMA	Aroma on	Aroma off				

Voice commands that are currently available:



AQUA FRESH	Aqua Fresh off	Aqua Fresh face on	Aqua Fresh body on	Aqua Fresh on completely
------------	-------------------	-----------------------	-----------------------	-----------------------------

VOICE GUIDE	Voice Guide on	Voice Guide off
-------------	----------------	-----------------

Volume	Volume plus	Volume minus
--------	-------------	--------------

Song	Song plus	Song minus
------	-----------	------------

Music source	Internal music on Music on	Own music on	Studio music on
--------------	----------------------------------	-----------------	--------------------

4 Cleaning and maintenance



4.1 Safety instructions when undertaking cleaning or maintenance work

 **DANGER!**



Electricity throughout entire device!
Personnel danger due to electric shock or electric burns.

- Before beginning work, disconnect all of the power connections from mains voltage.
- Secure all of the disconnected connections against accidental reactivation.
- Check that the device is disconnected from mains voltage.
- All of the work and electrical connections must comply with the national regulations of the country in which the device is being operated (e.g. the VDE regulations in Germany) and must be undertaken by appropriately trained specialists.

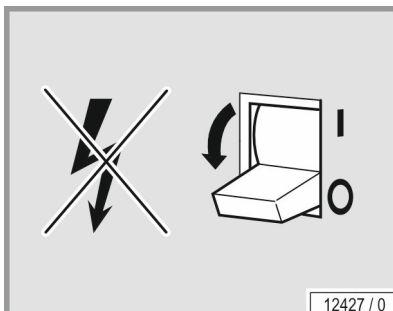

If work is to be performed on the devices, they must be deenergized. That means that all live cables must be switched off.

Switching off the unit alone is insufficient, as certain points may remain energized. Therefore, switch off fuses before performing any work and – if possible – remove them.

Accidental reactivation can result in serious accidents. Immediately after deenergizing, secure all switches or fuses used for deenergizing against being switched on again.

- Lock the fuse box with a padlock.

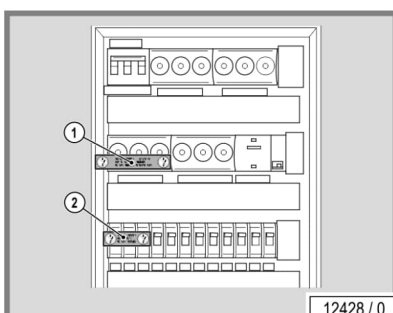

In case of circuit breakers which cannot be unscrewed, a strip of adhesive tape may be applied over the actuation lever with the wording 'Do not switch, danger!' (1 + 2).

A prohibition sign with the text:

'Work in progress!'

'Place:

'Sign may only be removed by:

must always be securely mounted immediately.



 CAUTION!



Risk of injury or eye disease!

Blue LEDs (FUSION LIGHT LEDs) of risk group 2 (classification according to standard DIN EN 62471, Photobiological safety of lamps and lamp systems) emit potentially dangerous optical radiation and may cause damage to eyes.

- Do not look into the lamp for prolonged periods when the blue LEDs are in operation.
- During cleaning or maintenance, deactivate the LEDs or wear protective goggles.

4.2 Faults

Error codes are output to the display to simplify troubleshooting:

- If a fault occurs, the error code appears in the display.
- If several faults occur, the fault messages are displayed alternately.
- The error is acknowledged by pressing the START/STOP-button.
- If the error cannot be cleared, inform Customer Service - see page 2.

More detailed information regarding the error description and solutions can be found in 'Error Codes', (Order No. 1019969-..).

4.3 Cleaning

 DANGER!



Infections can be spread by skin contact!

All objects/device parts that could come into contact with the user during tanning must be disinfected after every tanning session:

- Acrylic glass panel
- Handles and control panel
- Protective goggles
- Adjustable air nozzles

We recommend a suitable rapid surface disinfectant as a cleaning agent for rapid and thorough disinfection.



NOTE:

- To ensure thorough disinfection, always adhere to the contact time specified for the disinfectant. Follow the manufacturer's instructions for use.
- After the prescribed contact time, remove any remaining residues of the cleaning/disinfecting agents.
- Use a soft, clean single-use paper towel for this purpose.
- Carry out a visual inspection. Repeat the cleaning procedure if you find dirty areas or residues of the cleaning/disinfecting agent.
- Carry out a further visual inspection.



4.3.1 Cleaning the surfaces

Acrylic glass surfaces

CAUTION!

Do not rub dry – danger of scratching!

Failure to observe this will invalidate all guarantee claims.

- Only use a rapid surface disinfectant for acrylic glass panels for fast, hygienic proper cleaning of acrylic glass surfaces.
- Do not use disinfectants or solvents (e.g. Lysoform, ethyl alcohol, or other fluids containing alcohol).

Acrylic glass panels unusable due to soiling!

Soiling on the panels is burned in by the hot lamps and results in the long term in unserviceable panels.

- Remove fingerprints, cleaning residues and other soiling carefully.

Plastic surfaces

To clean the painted and unpainted plastic surfaces, it is best to simply use warm water and a leather cloth. Never use alcohol-based aggressive cleaning agents or essential oils. These cause damage that is not covered by warranty claims.

During cleaning a slight discolouration of the leather cloth by the rubber seals must be expected for production-related reasons.

Prevent damage to the acrylic glass and plastic surfaces.

- Remove rings, watches, bracelets etc. before starting cleaning work.

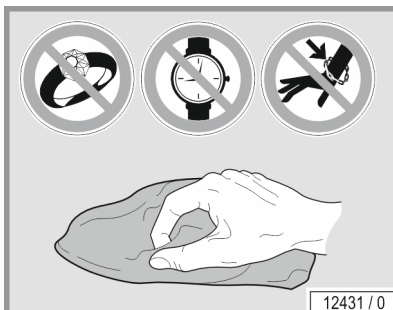



4.3.2 Lamps

The lamps can be cleaned with a damp cloth and without additional cleaning agents where necessary.

4.3.3 SPECTRA LED boards

 CAUTION!



SPECTRA LED boards are very sensitive optical components.

Risk of scratches!

Failure to observe this information will invalidate any warranty claims.



- Do not clean using mechanical equipment and do not clean with moisture!
 - Do not spray the components!
 - Do not buff or rub the components!
 - Do not vacuum the components!
 - If the components are dusty, use a clean, dry microfiber cloth.
 - Only use the microfiber cloth for SPECTRA LED boards!
 - Once used, clean the microfiber cloth according to the washing instructions for the cloth.
 - Do not insert the microfiber cloth directly into the reflector clusters. Risk of scratches!
 - Wipe the surface of the reflectors gently without applying any pressure!
 - If the SPECTRA LED boards need to be cleaned mechanically (buffed), always contact Customer Service before cleaning – see page 2.
-

4.4 Cleaning plan

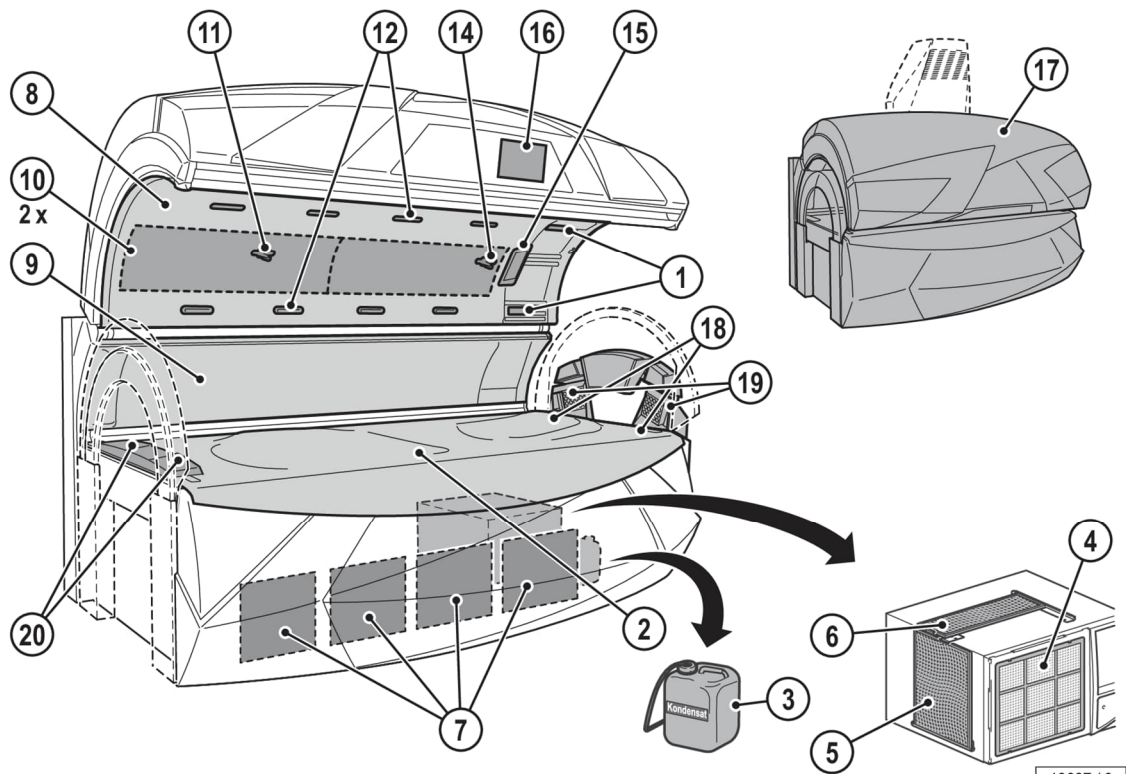

18837 / 3

Component	Interval	Activity	See page
	After each tanning session		
	When necessary		
		50 h	
1 Adjustable air nozzles/ AROMA	X	Clean and disinfect	48
2 Acrylic glass panel	X	Clean and disinfect	49
3 Condensation tank		X Empty	70
15 INTERIOR DISPLAY	X	Clean and disinfect	48
16 PROFESSIONAL SETUP MANAGER PLUS	X	Clean and disinfect	48
8, 9, 17 Surfaces		X Clean	49
Protective goggles	X	Clean and disinfect	48
11, 14 nozzles AQUA / AROMA SYSTEM		X Clean	48
12 Body cooling air nozzles		X Clean	48
5, 6 Filter		X Remove and clean filter	70
4 Filter mat		X Clean	70
7 Filter		X Remove and clean filter	68
10 Filter mats		X X Clean	69
18 Not available on this model.			



Component	Interval	Activity	See page	
19	After each tanning session	When necessary	50 h	
20	Body cooling air nozzles, feet end	X	Clean	48



NOTE:

When the cleaning mode is activated in PROFESSIONAL SETUP MANAGER PLUS and the run-on time of the device fan has finished, cleaning must be confirmed after every tanning session by pressing the START/STOP button.

4.5 Maintenance

Maintenance and care play a major role in deciding whether the device meets the requirements placed on it in a satisfactory manner. Compliance with the specified maintenance intervals and the careful conducting of the maintenance and care work are therefore absolutely necessary.

The current operating hours of maintenance parts can be called up in service mode (see 'PROFESSIONAL SETUP MANAGER PLUS'), order no. 1020179-..

We point out that the device must be subjected to regular inspections by our customer service or an approved specialized company every 12 months (from commissioning) to maintain its proper condition!

Inspections and maintenance work that has been carried out must be entered in the equipment, operating and maintenance booklet (order no. 1019967-..).

4.5.1 Acrylic glass

WARNING!



Cosmetics may cause cracks to form on the surface! Over the long-term cosmetics or sunscreens cause damage (e.g. crack formation on the surface).

- Ensure that cosmetics and sunscreens are removed before tanning.



The acrylic panels are made of acrylic glass that is specially developed for this field of application. The acrylics used are characterised by a particularly high UV permeability and resistance, as well as an easy-care, hygienic surface that is agreeable to the skin.

The acrylic glass panels are formed to device-specific shapes in a technically complex production process. Despite state-of-the-art production know-how, the presence of minor spots, air bubbles or streaks in the acrylic panels is unavoidable. In addition, hairline cracks can occur on the acrylic glass panel during operation.

These occurrences are material-related and are unavoidable in processing. However, they have no significant effect on use and are therefore not accepted as defects.

Over the course of time the acrylic glass panels becomes more translucent as a result of usage and must be replaced by customer-service personnel on a regular basis.

4.5.2 REMOTE SERVICE (optional)

Being the studio operator, you have the possibility to service your Prestige FUSION SPECTRA HYBRID via REMOTE SERVICE. You can call up device information, e.g. operating hours and conduct a device configuration via REMOTE SERVICE. In case of service, the technical services can carry out a remote diagnosis online via REMOTE SERVICE.



NOTE:

More information on registration and use as well as a REMOTE SERVICE user manual (order no. 1019772-..) can be found on the homepage of Globalservice: www.jk-globalservice.de.

4.6 Maintenance plan

WARNING!



Only use genuine spare parts of the same type! If other parts are used then the device no longer complies with the conformity declaration and may not be operated any longer!

Any liability for damage or injury proven to be the result of the use of non-genuine spare parts is excluded.

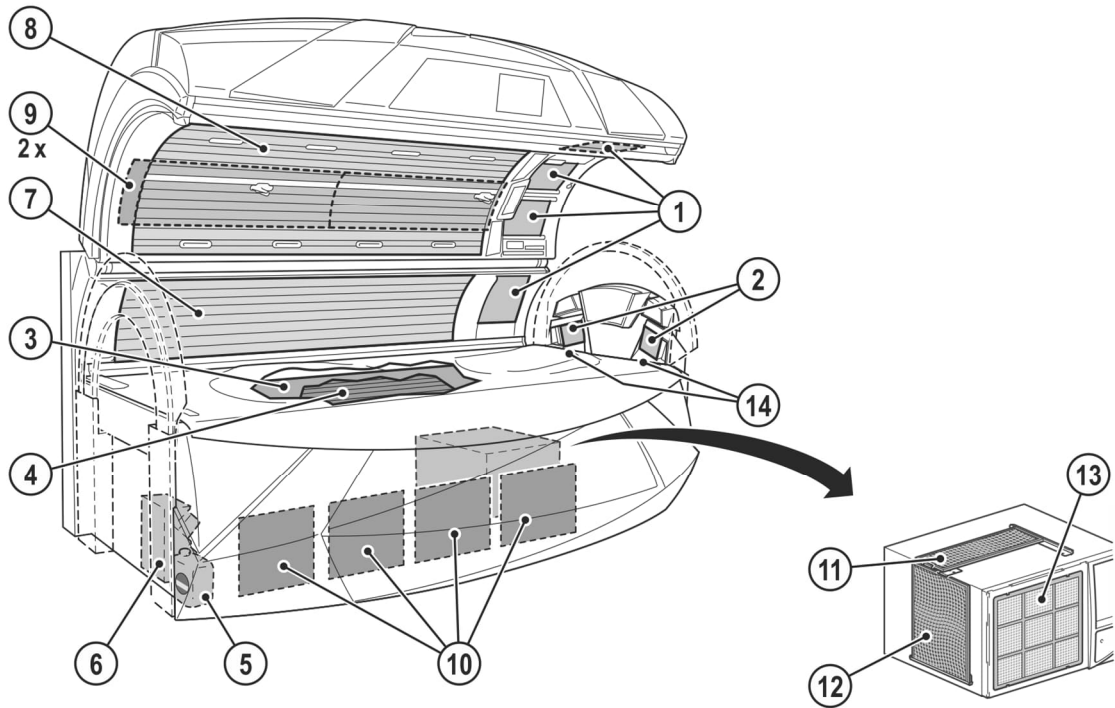

18834 / 1

Component	Interval				Activity	See page
	When necessary	300 Operating hours	500 Operating hours	1000 Operating hours / 3000 Operating hours / 2 years		
6 AQUA SYSTEM	X				Replace	73
5 AROMA tank		X			Replace	73
2	Not available on this model.					
1 Low-pressure lamp, facial tanner SPECTRA			X		Replace	67
4 Low-pressure lamps, base				X	Replace	65
7 Low-pressure lamps, side section				X	Replace	66
8 Low-pressure lamps, canopy				X	Replace	67
3 Partition				X	Replace	53
9 Filter mat				X	Replace	69
10 Filter				X	Replace	68
11 Filter				X	Replace	70
12 Filter				X	Replace	70
13 Filter mat				X	Replace	70
14	Not available on this model.					

Maintenance performed by authorized, trained and qualified staff

 **WARNING!**



Danger to people from maintenance work that has not been carried out!

If maintenance work is not carried out, it can lead to material damage or personal injuries!

- Maintenance work may only be carried out by trained and skilled personnel who have been authorised, instructed and qualified by JK-International GmbH, JK-Global Service department!
- The operator is responsible for compliance with the maintenance intervals!



The maintenance work must be carried out in accordance with checklist 1019858-.. by a JK Factory Certified Technician at the manufacturer or by personnel who have been authorized, trained and qualified by the manufacturer.

The correctly carried out maintenance work must be entered and confirmed in checklist 1019858-..

The maintenance work must be carried out at the following intervals:

- Every 1500 hours
- Annually or every 2000 hours, whichever is sooner.
- Every 3000 hours
- Every 5000 hours
- Every 100,00 hours
- After 10 years or 20,000 hours, whichever is sooner.

Once the age of the unit reaches ten (10) years from the date of manufacture, its condition must be assessed by a JK-International GmbH, Division JK-Global Service Certified Technician before use of the unit can be continued.

Failure to have this unit assessment performed may result in personal injury or property damage.

Any liability is excluded if use of the unit continues ten (10) years after the date of manufacture, without the "condition assessment" having been performed.



4.7 Cleaning and maintenance work preparation

4.7.1 Service kit

1. Allen key
2. Suction cup for acrylic glass panel and canopy panel
3. Scratch prevention for the entry area (support cushion for the canopy)

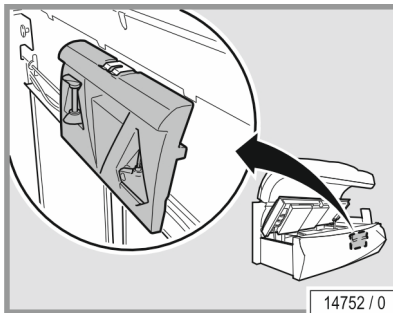
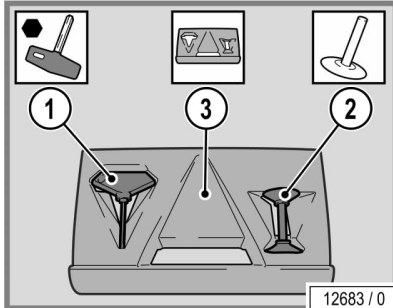

The service kit is fitted on the inside of the front panel.

- Opening the bed base: see page 60.

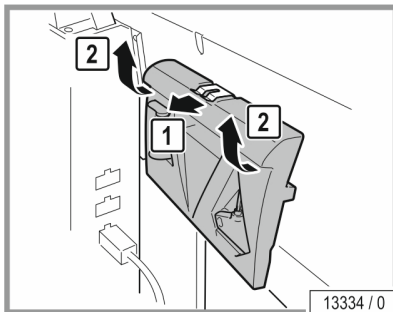

- Remove service kit from holder.

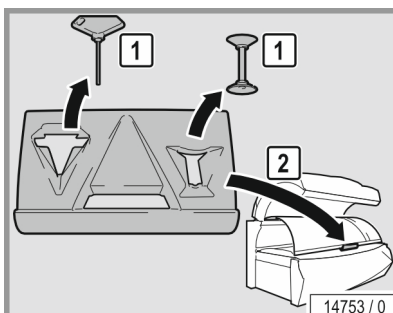

- Remove the Allen-key and suction cup.

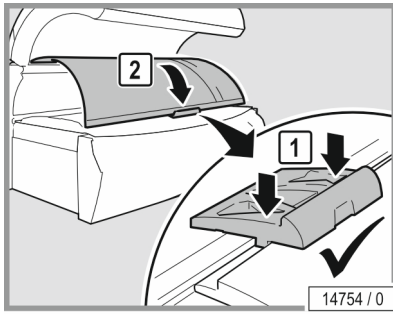

- Use the cushion as scratch prevention when opening the canopy panel.



4.7.2 Lift up the acrylic glass panel and remove the partition

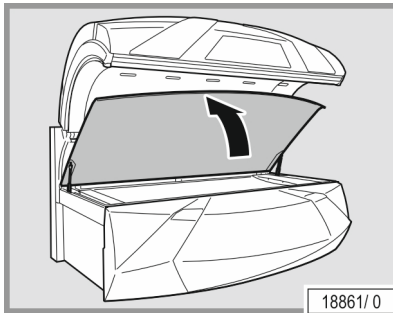

- Lift the acrylic glass panel up to the stop. The acrylic glass panel will automatically be held in place.

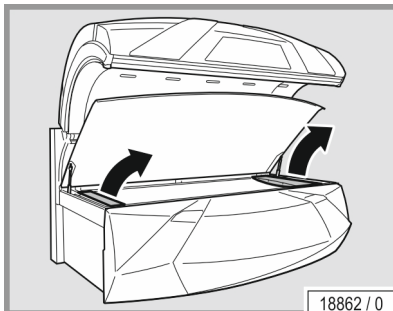

- Remove the lamp covers at the head and foot ends.

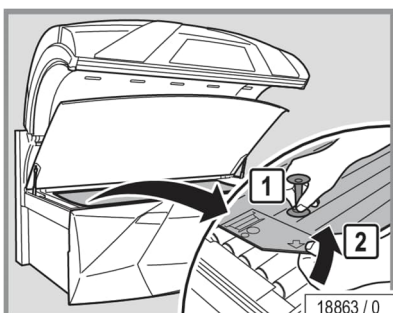

- Raise the partition with the suction cup.
- Remove the partition.

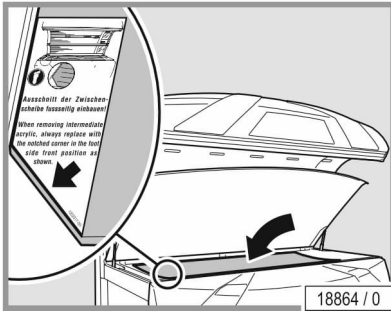

The assembly is the same process in reverse order.

When assembling the device please note:

- You must ensure that the recesses are at the foot end when you fit the partition.

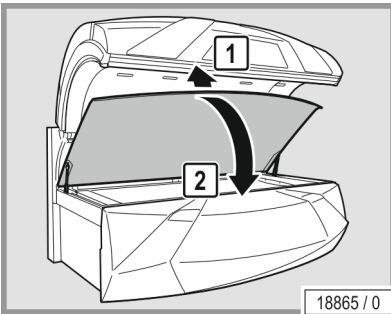

- Lift the acrylic glass panel up slightly and then close it.

4.7.3 Removing the canopy panel

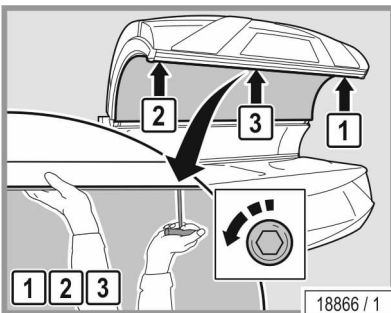

- Turn the locks through 90°: first the outer locks, then the lock in the middle.
- Support the canopy panel with one hand so that it does not fall down.

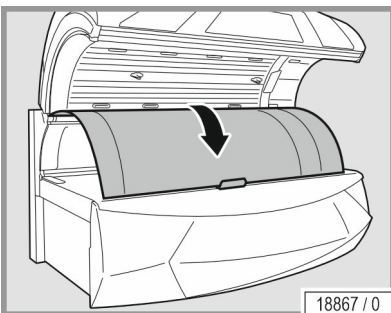

- Carefully lay the panel aside on the scratch protection (service kit).

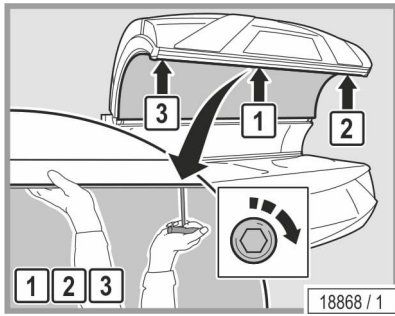

The assembly is the same process in reverse order.

When assembling the device please note:

- Support the canopy panel with one hand so that it does not fall down.
- Re-lock the locks: first the lock in the middle, then the outer locks.



4.7.4 Removing the side section panel

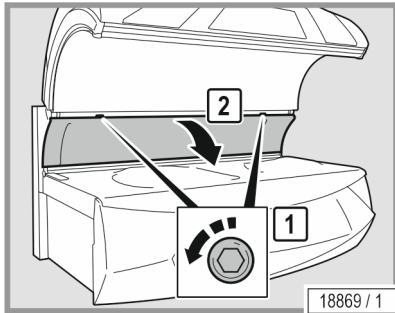

- Turn the locks through 90°.

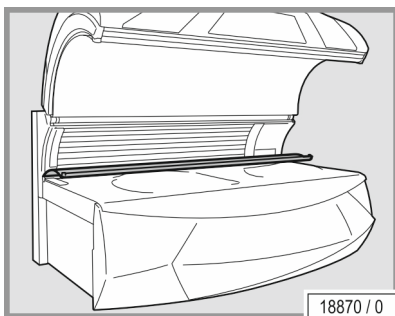

- Open the panel and lay it down carefully.

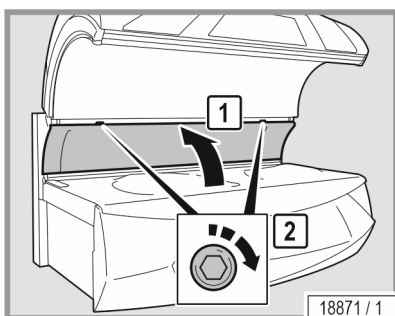

When assembling the device please note:

- Re-lock the locks.

4.7.5 Opening the bed base

- Press the bed base gently downwards.
- Release the lock at the head end.

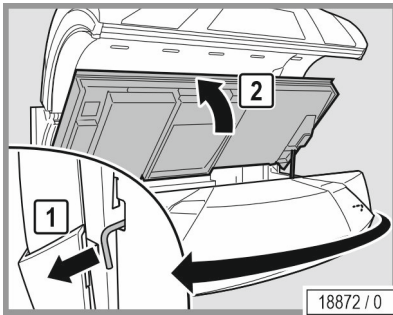

- Lift up the bed base.

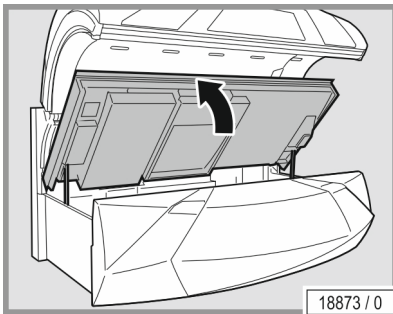

- Close the bed base. You should hear the bed base click into place.

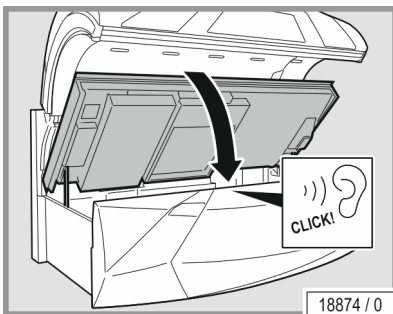

4.8 Instructions for replacing the lamps



DANGER!



Danger of burns from hot lamps and surfaces!
Finger and hands may get burned when replacing lamps.

- Before carrying out maintenance work, wait until the device has cooled down sufficiently.



NOTICE:

Small quantities of mercury can escape if the lamp glass breaks! Please comply with the following instructions:

- Immediately disconnect the device from the mains power.
- Children must leave the room immediately.
- Ventilate the room for at least 15 minutes.
- Put on disposable gloves.
- With the window open: Collect the glass shards and escaped mercury in a sealable container.
- Bring the container to a collection site for waste lamps.



4.8.1 NFC: Lamp replacement

 **DANGER!**



Sunburn due to excessive lamp output!

If a new lamp set is installed without resetting the lamp operating hours, the new lamps may be operated with an excessive output. This can lead to sunburn.

- When replacing the UV low-pressure lamps, always use the enclosed NLC lamp card.

Each new lamp set must be activated with the accompanying NFC lamp card. Each NFC lamp card can only be used one time, then it is invalid.

The lamp set must be installed first, then the lamps have to be activated with the NFC lamp card. For this purpose, the operating hours must be reset.

Resetting the operating hours



NOTE:

To reset the operating hours of the lamps, you need access to the PROFESSIONAL SETUP MANAGER PLUS.

- Go to PROFESSIONAL SETUP MANAGER PLUS.
- Activation in the menu OPERATING HOURS.

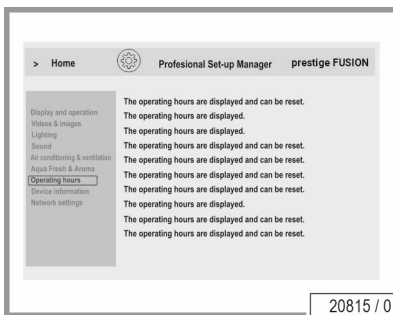
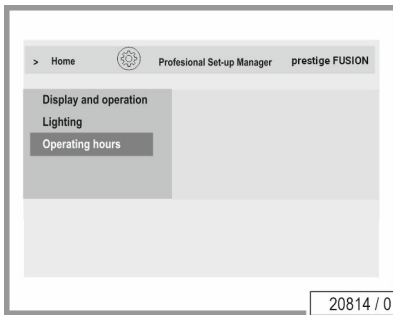

- Hold the NFC lamp card against the NFC point.



The middle point of the NFC point is green:
The operating hours of the lamps are reset to 0.



NOTE:

Both NFC lamp cards must be activated. Hold the NFC lamp card of lamp set type A and the NFC lamp card of lamp set type B against the NFC point one after another.

4.8.2 Low-pressure lamps

 **DANGER!**



Danger of burns from hot lamps and surfaces!
Finger and hands may get burned when replacing lamps.

- Before carrying out maintenance work, wait until the device has cooled down sufficiently.

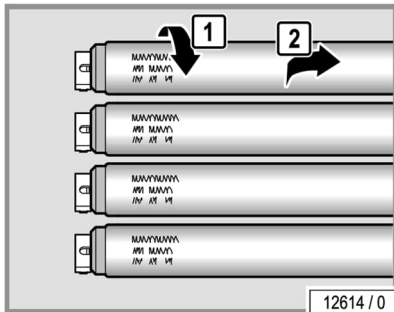

- Replace faulty low-pressure lamps immediately.
- Always replace the entire set of lamps after the specified operating time.
- Turn 90° and carefully remove from the socket.

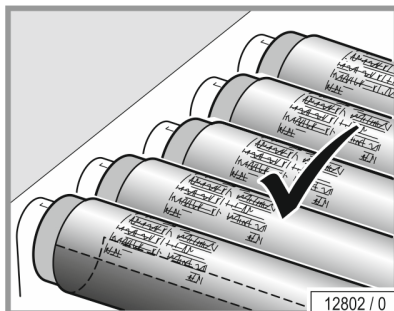

- Low-pressure lamps possess a reflector which directs the light outwards.
- The lamps must be mounted so that the rear side of the reflector faces the interior of the unit.

 **WARNING!**



Risk of fire due to incorrect alignment of the lamps!
Incorrect alignment of the lamps leads to loose connections. This can cause overheating and sparking.

- Check that the socket is correctly aligned!

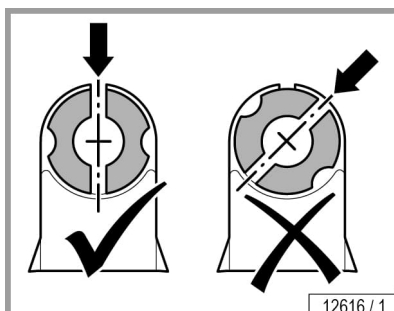

- Before inserting the new lamp, the alignment of the inner part of the socket must be checked.

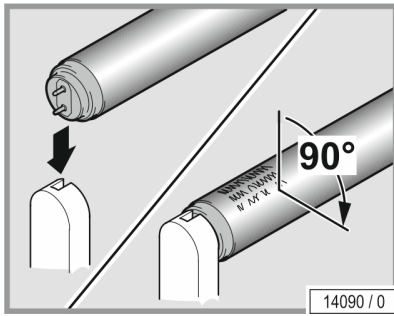

- Insert the contact pins of the lamps vertically into the socket from above.
- For correct contacting, the lamp must be rotated 90° around its own axis.
- The lettering must be oriented towards the outside (i.e. towards the tanning room or towards the user).

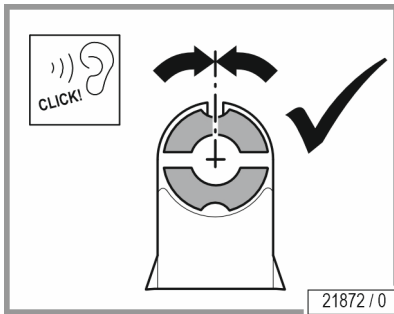

4.8.3 Starter

Not available on this model.

4.9 Cleaning or replacing lamps in the base

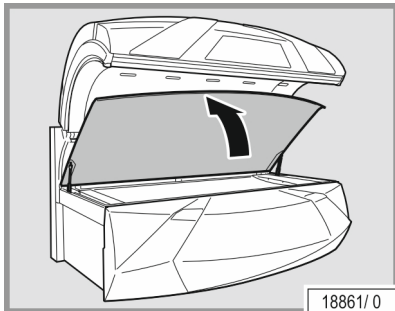

18861 / 0

- Lift up the acrylic glass panel and then remove the lamp covers and the partition: see page 57.

Replacing lamps: see page 63.

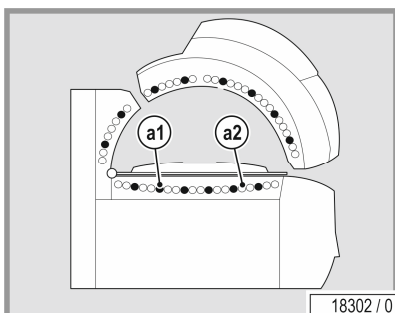

18302 / 0

- Pay attention to the order of the low-pressure lamps and ERGOLINE HYBRID / BLUE low-pressure lamps.
a1: ERGOLINE HYBRID / BLUE low-pressure lamps
a2: Low-pressure lamps

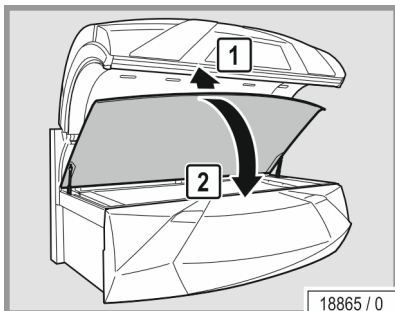

18865 / 0

The assembly is the same process in reverse order.

When assembling the device please note:

- You must ensure that the recesses are at the foot end when you fit the partition.
- Lift the acrylic glass panel up slightly and then close it.



4.10 Cleaning or replacing the lamps in the side section

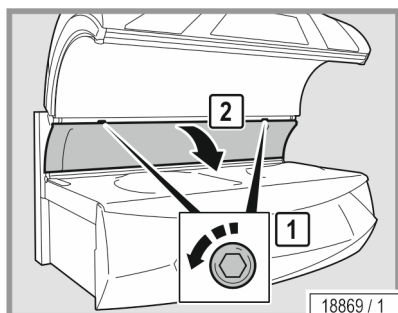

- Removing the side section panel: see page 59.

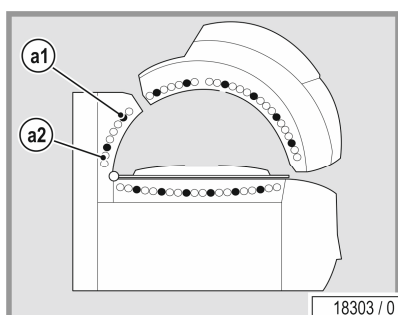

- Pay attention to the order of the low-pressure lamps and ERGOLINE HYBRID / BLUE low-pressure lamps.
a1: ERGOLINE HYBRID / BLUE low-pressure lamps
a2: Low-pressure lamps

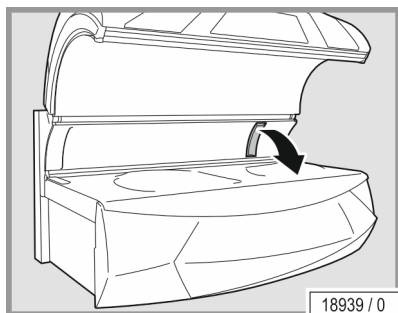

- Remove the lamp cover.
Replacing lamps: see page 63.

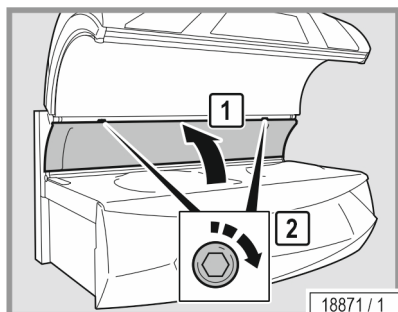

- When assembling the device please note:
- Re-lock the locks.

4.11 Cleaning or replacing lamps in the canopy

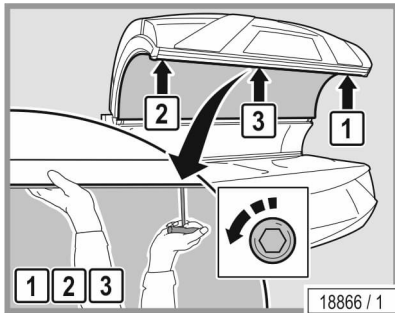

The following components listed in the maintenance plan are fitted in the canopy:

- Low-pressure lamps 1.80 m

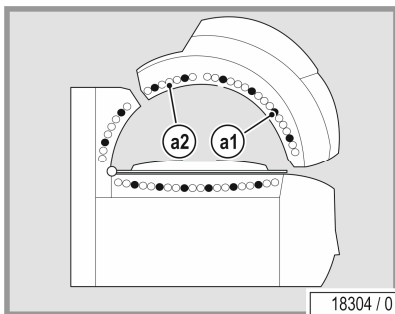

- Pay attention to the order of the low-pressure lamps and ERGOLINE HYBRID / BLUE low-pressure lamps.
a1: ERGOLINE HYBRID / BLUE low-pressure lamps
a2: Low-pressure lamps

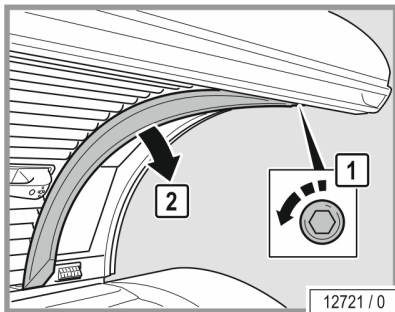

- Remove screw and place the lamp cover carefully on top of the canopy panel.

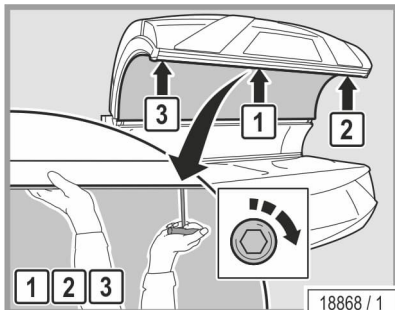

The assembly is the same process in reverse order.

When assembling the device please note:

- Support the canopy panel with one hand so that it does not fall down.
- Re-lock the locks: first the lock in the middle, then the outer locks.



4.12 Cleaning or replacing the low-pressure lamps in the shoulder tanner

Not available on this model.

4.13 Cleaning the filters in the base

- Opening the bed base: see page 60.

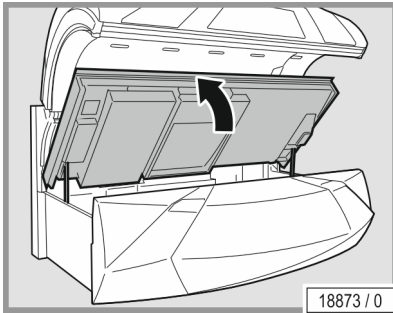

- Remove the filters.

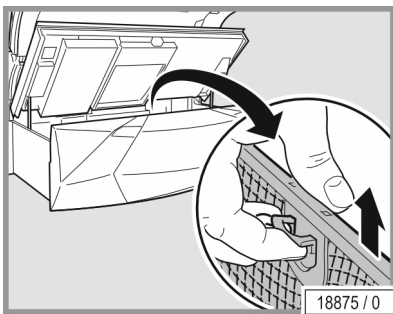

- Cleaning the filters when moist or dry.

Dry cleaning: Vacuum cleaner (depending on the degree of soiling)

Moist cleaning: Use water and detergent or put in a dish-washer

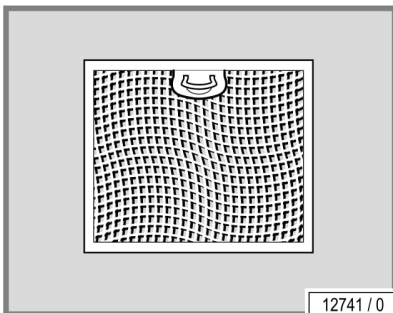

 **WARNING!**



The device may be damaged by moisture!
The cleaned filters must be dry before they are replaced.

- Refit the cleaned and dried filters.
- Close the bed base. You should hear the bed base click into place.

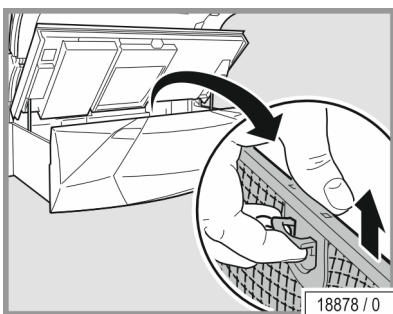

4.14 Cleaning the canopy filter mats

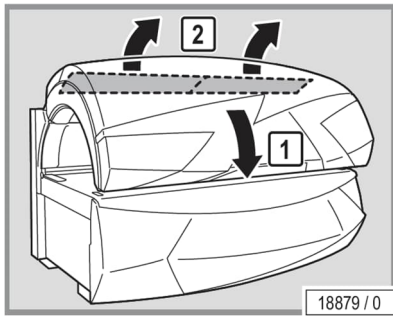

18879 / 0

- If necessary, cover the canopy in order to prevent the paint from being scratched.
- Remove the filter mats fitted at the back of the canopy.

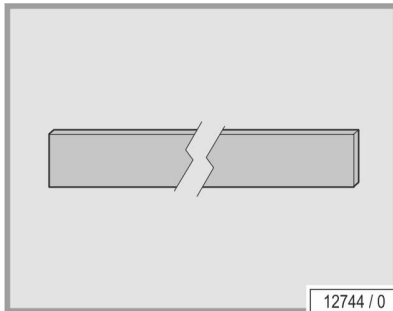

12744 / 0

- Dry or moist clean the filter mats or replace with new ones.
 Dry cleaning: Vacuum cleaner (depending on the degree of soiling)
 Moist cleaning: water and detergent
- Do not clean in the dish-washer!

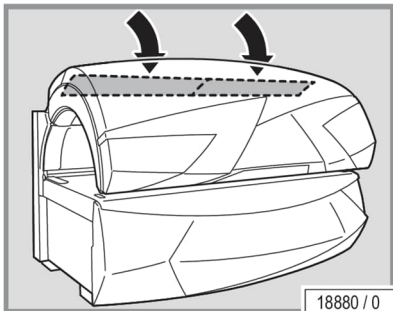

18880 / 0

WARNING!



The device may be damaged by moisture!
 The cleaned filters must be dry before they are replaced.

- Refit the cleaned and dried filter mats.

4.15 Cleaning filter mats in the shoulder tanner

Not available on this model.



4.16 Air conditioning: Empty the condensation tank and cleaning the filter

WARNING!



Damage to the device through soiled filters and cooling fins!

Regularly check the filter grill and cooling fins on the air conditioning system and clean if necessary.

We recommend using the specially manufactured fin comb, art-no. 15720470, to clean the cooling fins.

CAUTION!



Inflammable refrigerant in the air conditioning system!

Leaking refrigerant can lead to fires or explosions.

- Avoid sources of ignition! Fire, naked flames and smoking are prohibited.
- No servicing work may be carried out on components in the cooling circuit, e.g. on the compressor, pressure switch or frequency inverter.
- Do not perform any soldering or welding work on the unit.



NOTE:

The air conditioner contains fluorinated greenhouse gases. Do not release gases into the atmosphere. Information regarding the refrigerant used:

Currently in use are refrigerant R410A ⁽¹⁾GWP: 2088¹⁾ or R134A ⁽¹⁾GWP: 1430) or R32 ⁽¹⁾GWP: 675).



NOTE:

Details on the refrigerant used and the amount can be found on the type plate of the air conditioning system.

- Opening the bed base: see page 60.

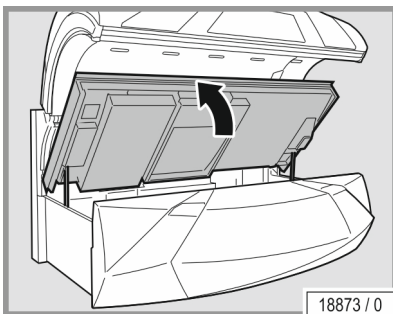

¹ GWP = global warming potential

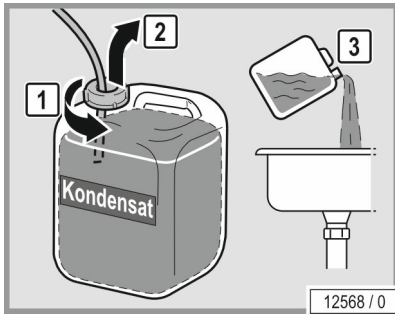

- Bring the condensation tank forwards.
- Disconnect the hose on the condensation tank.
- Empty the condensation tank.

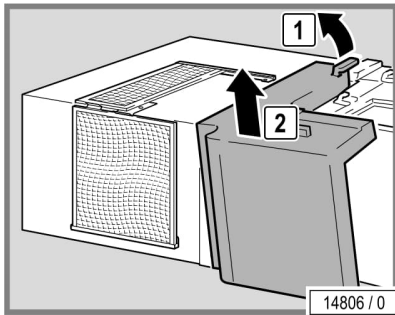

- Remove the cover.

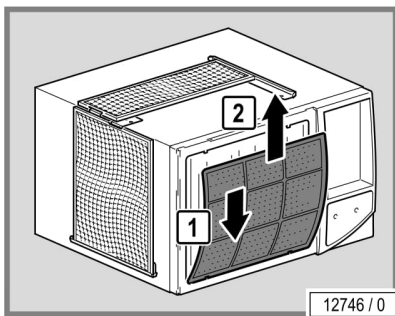

- Remove the filter from the holder.

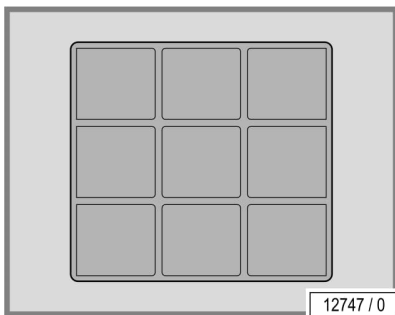

- Cleaning the filters when moist or dry.
- Dry cleaning: Vacuum cleaner (depending on the degree of soiling)
 Moist cleaning: Water and detergent
- Do not clean in the dish-washer!

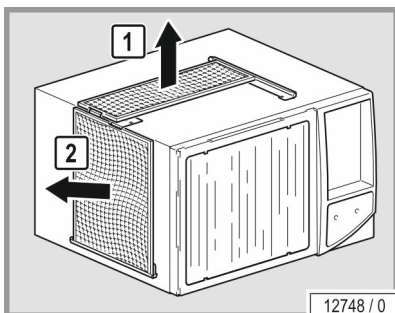

- Remove the filter from the holder.

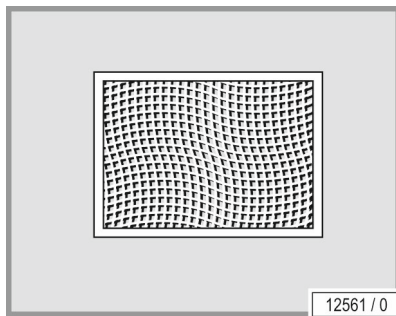

- Cleaning the filters when moist or dry.

Dry cleaning: Vacuum cleaner (depending on the degree of soiling)

Moist cleaning: Use water and detergent or put in a dish-washer

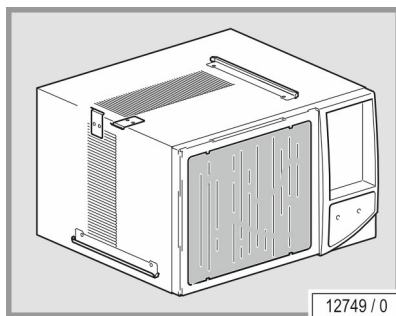

- Use a fin comb to clean the air conditioning's dirty cooling fins.

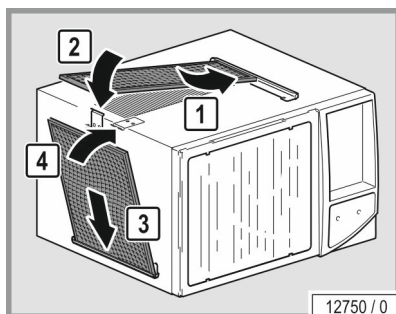

! WARNING!



The device may be damaged by moisture!
The cleaned filters must be dry before they are replaced.

- Refit the cleaned and dried filters.
- Ensure that the filters are correctly positioned in the holder.

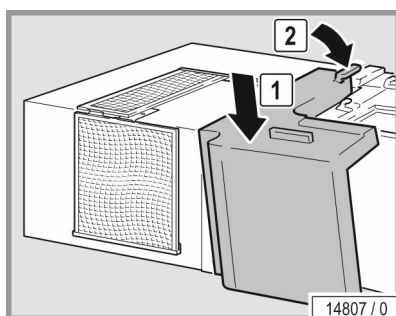
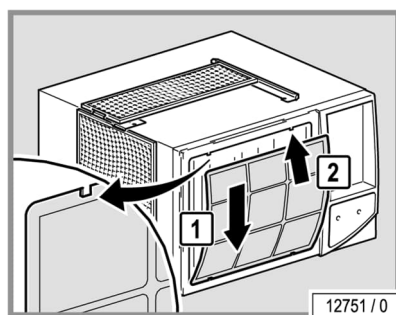

- Attach the cover.

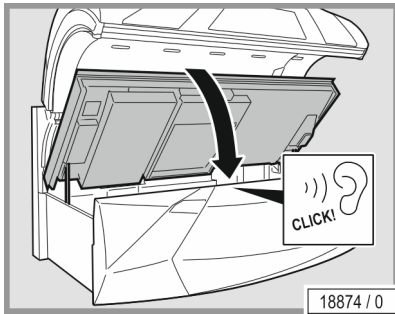

- Connect the condensation tank to the hose.
- Refit the condensation tank.
- Close the bed base. You should hear the bed base click into place.



4.17 AQUA / AROMA system maintenance

The AQUA SYSTEM function sprays a fine mist of AQUA SOLAR WITH SKIN+ ADDITIVE into the interior of the device for body cooling (see 'AQUA SYSTEM PRODUCT INFORMATION', order no. 1011201-..).

DANGER!



Customer health hazard!

Water that has been contaminated with bacteria can cause skin rashes and other allergic reactions in device users.

- Therefore you must never fill the AQUA SYSTEM canister with tap water or other liquids.
- Only replace the AQUA SYSTEM canister with a genuine canister.
- Do not add any liquid that remains in the old canister to the new canister!
- Ensure that the maximum temperature specified is not exceeded during transport and storage.
- Note the expiry date on the canister.

The AQUA / AROMA SYSTEM also includes the fragrance 'RELAX' which is distributed via the head nozzles as well as in the cabin.

Other fragrances are also available. Contact JK-International GmbH, Division JK-Licht for further details (see page 2).

4.17.1 Changing the AROMA canister

- Opening the bed base: see page 60.

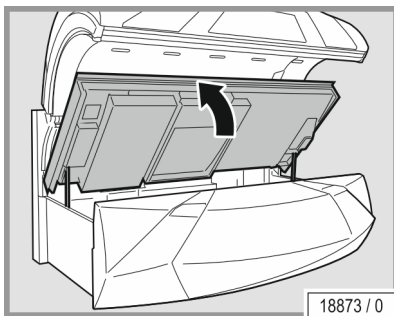

- Remove the AROMA canister.

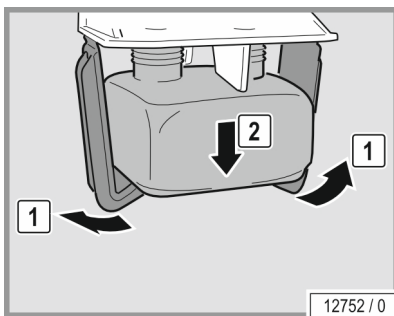

- Unscrew the lid on the new canister.
- Write the date on the canister.

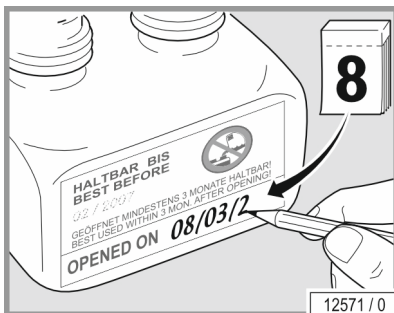

- Fit the canister in the holder.
- Close the bed base. You should hear the bed base click into place.

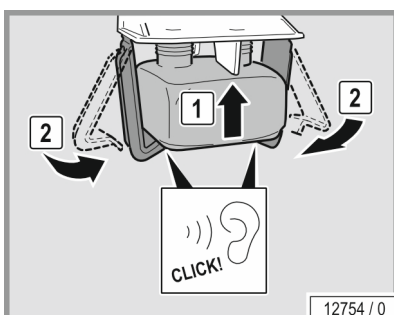

4.17.2 Replacing the AQUA SYSTEM canister

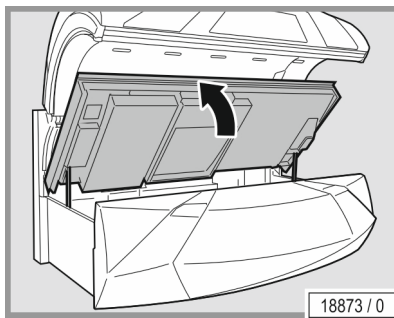

- Opening the bed base: see page 60.

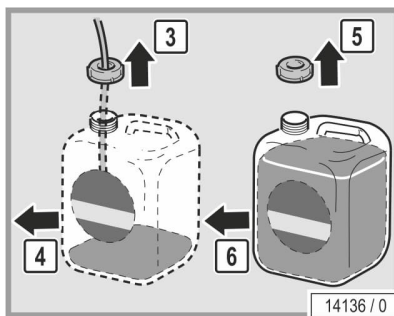

- Remove the canister.
- Unscrew the lid on the new canister.
- Remove the lid with the hose from the old canister.

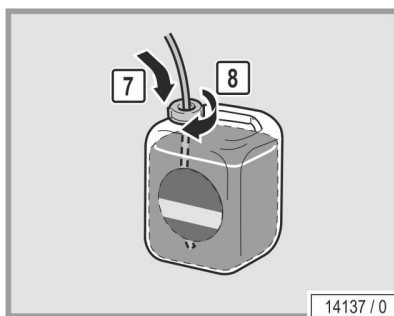

- Screw the lid with the hose onto the new canister.
- Push the hose well down so that it touches the bottom of the canister.
- Put the canister back in the device.
- Close the bed base. You should hear the bed base click into place.

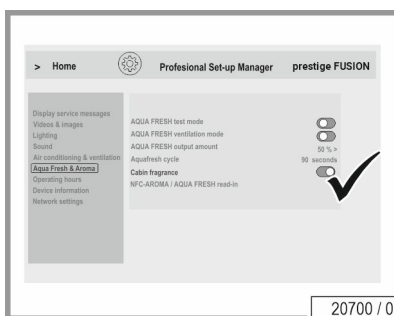

Venting



NOTE:

To ventilate, access to PROFESSIONAL SETUP MANAGER PLUS is required.

- Go to PROFESSIONAL SETUP MANAGER PLUS.
- Activate the fill mode in the AQUA FRESH & AROMA menu.

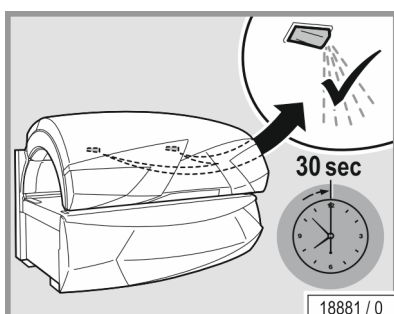

- Close the canopy.

The system will now be ventilated for 30 seconds. The AQUA SYSTEM liquid will be released from the nozzles during this period.

- Then test the AQUA SYSTEM in test mode. In test mode, the nozzles spray for 3 seconds. Repeat the ventilation process if it does not work.

5 Technical data



5.1 Power, connection rating and noise level

Prestige FUSION SPECTRA HYBRID / Prestige FUSION SPECTRA UV BLUE

Power consumption rating with Climatronic:	14400 W		
Rated frequency:	50 Hz		
Rated voltage:	400-415 V 3N~		230-240 V ~3
Rated fuses:	3 x 35 A (inactive)	or	3 x 50 A (inactive)
Connecting line:	H05VV-F 5G 4 mm ² (scope of delivery)		H05VV-F 4G 10 mm ²
Noise level 1m away from device:	62,9 dB(A)		
Noise level inside the device:	<70 dB(A)		
Load on the acrylic glass panel:	max. 135 kg		
Weight:	600 kg		

5.2 Dimensions

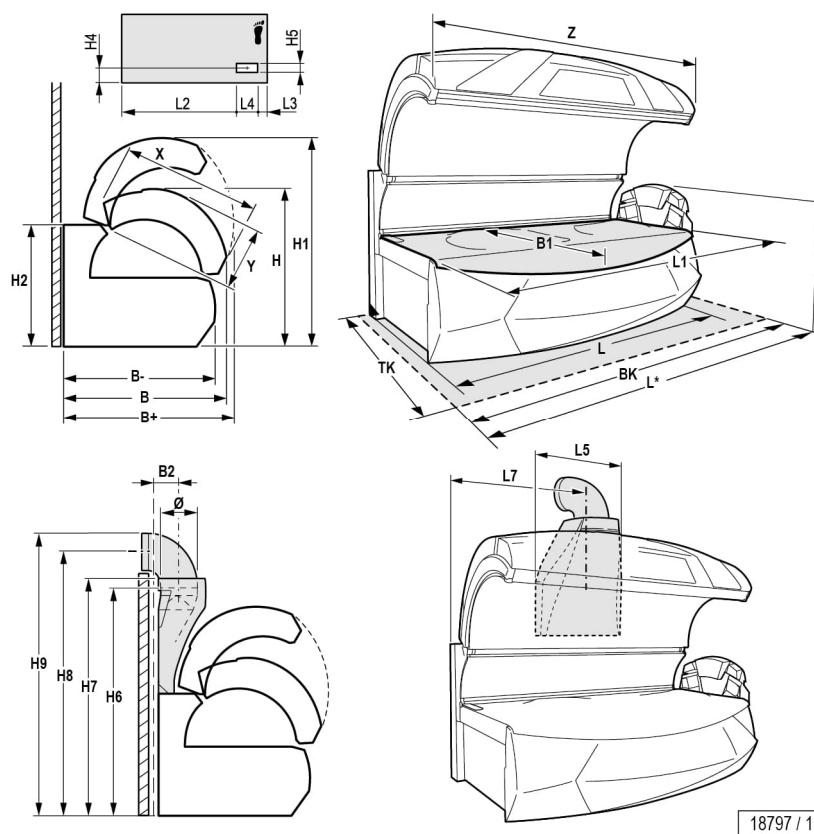

18797 / 1

Prestige FUSION SPECTRA HYBRID /
Prestige FUSION SPECTRA UV BLUE:

B+ = 1555 mm	H = 1510 mm
B = 1550 mm	H1 = 1980 mm
B- = 1500 mm	H2 = 1106 mm
B1 = 1220 mm	H4 = 450 mm
B2 = 205 mm	H5 = 56 mm
L = 2415 mm	H6 = 1879 mm
L1 = 2200 mm	H7 = 2002 mm
L2 = 1756 mm	H8 = 2215 mm
L3 = 235 mm	H9 = 2360 mm
L4 = 243 mm	Ø = 300 mm
L5 = 867 mm	BK = 2500 mm
L7 = 1120 mm	TK = 2300 mm
X = 1290 mm	
Y = 670 mm	
Z = 2240 mm	



5.3 Lamp sets

! WARNING!



The conformity declaration applies for the specified lamps. The use of other lamps voids the operating licence.

Moreover, the lamps must be marked with a matching equivalence key, see attachment page 81.

5.3.1 Prestige FUSION SPECTRA HYBRID

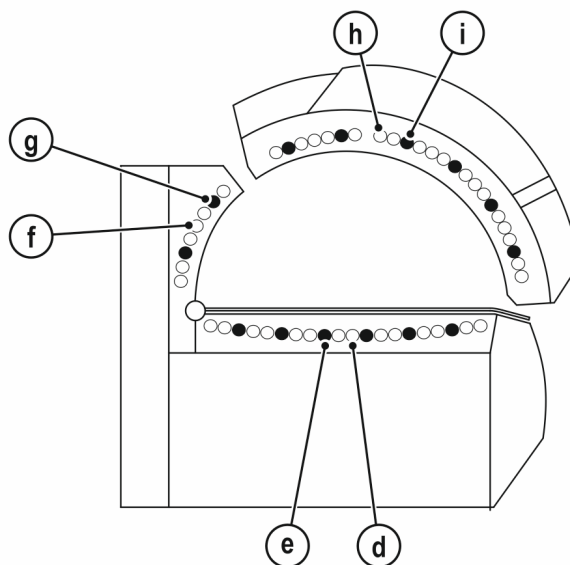
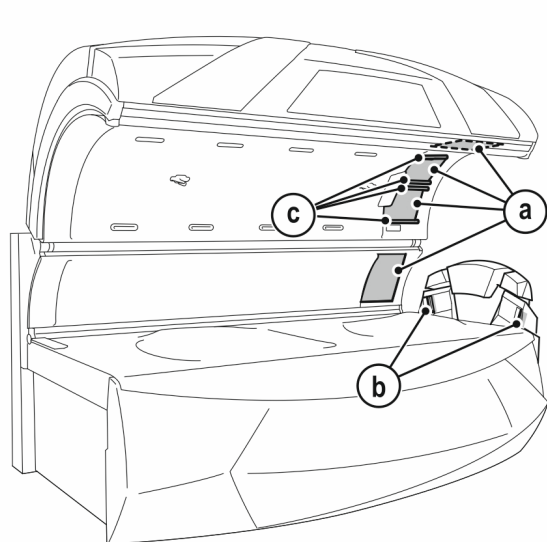

18945 / 1

Lamp sets

Number	Description	Length	Power	Control	Order-no.
a)	4 ERGOLINE UV-LED Board SPECTRA			dimnable	1512186-..
b)	2 ERGOLINE UV-LED Board SB				1513795-..
c)	4 Low-pressure lamps ERGOLINE SMARTSUN 35 8W	0,31 m	8 W	8 W / 0 W	1512461-..
d)	14 UV low-pressure lamps ERGOLINE TREND ADVANCED 80-200 EP 104 160W R	1,80 m	160 W	80-200 W	1511231-..
e)	6 Low-pressure lamps SMART SUN+ R 27 160W	1,80 m	160 W	80-200 W	1511232-..
f)	6 UV low-pressure lamps ERGOLINE TREND ADVANCED 80-200 EP104 160W R	1,80 m	160 W	80-200 W	1511231-..
g)	2 Low-pressure lamps SMART SUN+ R 27 160W	1,80 m	160 W	80-200 W	1511232-..
h)	18 UV low-pressure lamps ERGOLINE TREND ADVANCED 80-200 EP104 160W R	1,80 m	160 W	80-200 W	1511231-..
i)	6 Low-pressure lamps SMART SUN+ R 27 160W	1,80 m	160 W	80-200 W	1511232-..

5.3.2

Prestige FUSION SPECTRA UV BLUE

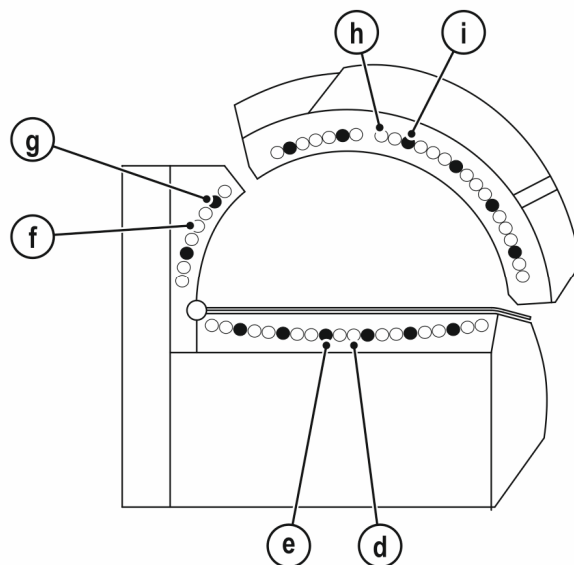
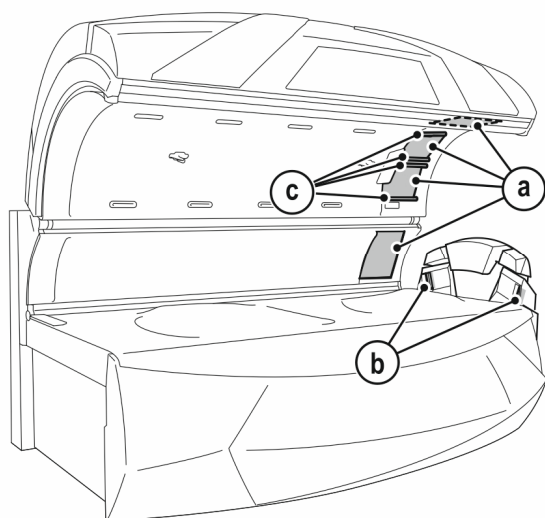

18945 / 1

Lamp sets

Number	Description	Length	Power	Control	Order-no.
a)	4 ERGOLINE UV-LED Board SPECTRA			dimmable	1512186-..
b)	2 Ergoline UV-LED Board SB				1513795-..
c)	4 Low-pressure lamps ERGOLINE TREND E12 8W	0,31 m	8 W	8 W / 0 W	1512462-..
d)	14 UV low-pressure lamps ERGOLINE TREND ADVANCED 80-200 EP 104 160W R	1,80 m	160 W	80-200 W	1511231-..
e)	6 Low-pressure lamps ERGOLINE BLUE 80-200 160W EP201 R	1,80 m	160 W	80-200 W	1512082-..
f)	6 UV low-pressure lamps ERGOLINE TREND ADVANCED 80-200 EP 104 160W R	1,80 m	160 W	80-200 W	1511231-..
g)	2 Low-pressure lamps ERGOLINE BLUE 80-200 160W EP201 R	1,80 m	160 W	80-200 W	1512082-..
h)	18 UV low-pressure lamps ERGOLINE TREND ADVANCED 80-200 EP104 160W R	1,80 m	160 W	80-200 W	1511231-..
i)	6 Low-pressure lamps ERGOLINE BLUE 80-200 160W EP201 R	1,80 m	160 W	80-200 W	1512082-..



5.4 Spare parts and accessories

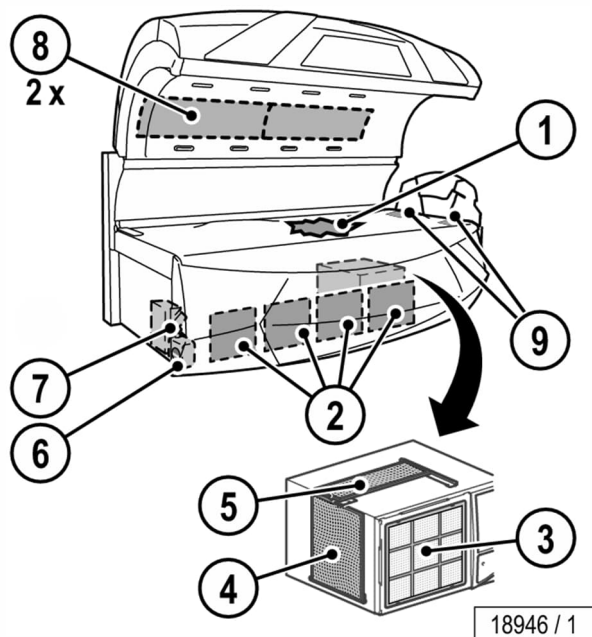

18946 / 1

Number	Description	Order-no.
1	1 Partition	1500339-..
2	4 Filter	52104-..
3	1 Filter mat	—
4	1 Filter	51937-..
5	1 Filter	55567-..
6	1 AQUA SYSTEM, 6000 ml	800617-..
7	1 AROMA, 100 ml RELAX	701357-..
8	2 Filter mats	843150-..
9	Not available on this model.	
	1 Protective goggles	1027211-..
	1 NFC lamp card for the UV lamp set TREND ADVANCED EP104 (UV BLUE and Hybrid)	1511265-..
	1 NFC lamp card for the lamp set ERGOLINE BLUE EP201 (UV BLUE)	1512107-..
	1 NFC lamp card for the lamp set SMARTSUN (Hybrid)	1511266-..

6 Appendix



6.1 JK timer controls

The following time control system can be utilised with the PRESTIGE series units:

HK MICROTIMER 8250 order no.: 500001653

6.2 Equivalence key range

Example for calculating the equivalence key range (1), see the lamp configuration sticker:

If the equivalence key of the lamp with which the device has been equipped during the type approval is

100-R-47/2,7

the equivalence key range with which the device should be marked is calculated as follows:

Bottom value of the X section: $0,75 \times 47 = 35,25$

Bottom value of the Y section: $0,75 \times 2,7 = 2,03$

Top value of the Y section: $1,25 \times 2,7 = 3,38$

X is rounded up to the next whole value, Y will be rounded to the first decimal place after the point.

The equivalence key range for fluorescent lamps is then:

100-R-(35-47)/(2,0-3,4)

				Ergolite E8P8T 170-S DYNAMIC POWER			
	①	18x		Ergolite TREND 89-200 W E8	1694288-	100-R- (35-47)/(2,0-3,4)	
	②	8x		Ergolite TREND 89-200 W E8	1694288-	100-R- (35-47)/(2,0-3,4)	
	③	32x		Ergolite TREND 89-200 W E8	1694288-	100-R- (35-47)/(2,0-3,4)	
	④		4x	2x	Ergolite ULTRA 82W ULTRA PERFORMANCE 82	1694284- 1694284-	
		3x		2x	Ergolite ULTRA 82W ULTRA PERFORMANCE 82	1694284- 1694284-	
⑤	-	-	-	Ergolite TREND 89-200 W E8	-	100-R- (35-47)/(2,0-3,4)	
⑥		2x	2x	Ergolite ULTRA 100 W ULTRA PERFORMANCE 82	1694284- 1694284-		
			2x	ULTRA PERFORMANCE 82	1694284- 1694284-		
JK-Products GmbH / GERMANY				1000000-01			

13192 / 1



6.2.1 Description of the equivalence keys for fluorescent lamps

The equivalence key for fluorescent lamps for tanning that is represented in detail in the IEC 61228 and that is marked on the lamp in a readable and permanent manner, is described in the following.

The equivalence key has the following structure:

Wattage – Reflector type key – UV key.

The following reflector type key should be used for the equivalence key:

O with lamps without reflector;

B with lamps that have a wide reflecting angle $\alpha > 230^\circ$;

N with lamps that have a narrow reflecting angle $\alpha < 200^\circ$;

R with lamps that have the usual reflecting angle $200^\circ \leq \alpha \leq 230^\circ$.

The following UV key should be used for the equivalence key:

UV key = X/Y;

X = the entire effective erythemal UV radiation strength across the range 250 nm to 400 nm;

Y = the relationship of the non-melanoma skin cancer effective UV radiation strength ≤ 320 nm and > 320 nm.

X is specified in mW/m^2 and rounded up to the next whole value, Y will be rounded to the first decimal place after the point. The effective values apply for a distance of 25 cm and under the conditions of an optimum UV radiation strength.

Note

One example for an equivalence key is specified below:

- 100 W reflector lamp with a reflector angle of 220°
- erythemal UV radiation strength (250 nm to 400 nm) = $47 \text{ mW}/\text{m}^2$
- short wave NMSC effective UV radiation strength (≤ 320 nm) = $61 \text{ mW}/\text{m}^2$
- long wave NMSC effective UV radiation strength (> 320 nm) = $19 \text{ mW}/\text{m}^2$
- lamp equivalence key: 100–R–47/2,7

7 Index



A

Accessories.....	31, 80
Acrylic glass (care)	49
Acrylic glass panel - sunbed	53
Acrylic glass panel, permitted load.....	76
Acrylic glass panels (product information).....	53
Adolescents	8, 32
Allergies.....	32
AQUA / AROMA system maintenance.....	73
Assembly.....	15
Audio files	20

B

Bluetooth®	42
------------------	----

C

Care	48
Changing the AROMA canister	74
Children	10
Cleaning.....	47, 48
Air conditioning	70
Air conditioning filter	70
Filter mats.....	69
Lamps	50
Cleaning intervals	51
Cleaning or replacing	
Side section	66
Cleaning or replacing lamps	
Canopy	67
Cleaning or replacing the lamps	
Base.....	65
Cleaning overview.....	51
Cleaning the filter.....	68, 69
Cleaning, filter	68
Commissioning.....	17
Contact lenses	32
Cosmetics	10
Customer service.....	2



D

Damage28
 Decommissioning..... 18
 Definitions6
 Description.....30
 Device operating time17
 Dimensions77
 Directives20
 Disposal19

E

E.V.A.45
 Electrical installation15
 Electrical specifications76
 ELECTRONIC VOICE ASSISTANT45
 Emptying the condensation tank70
 Equipment29
 Equivalence key range81
 Error codes48
 Exhaust air ventilation15
 Export20
 Eye damage32

F

Faults48
 Filter
 Cleaning intervals51
 Foreseeable misuse8
 Functions36

I

Illnesses32
 Intended use8
 Itching32

L

Lamp sets78
 Lamps8
 Control78
 Power levels78
 Rated power78
 Liability28
 Lift up the acrylic glass panel57
 Light sensitivity32

M

Maintenance	47, 52
Maintenance intervals	53
Maintenance overview.....	53
Make-up.....	32
Medicaments	32
Music	20, 44



N

Network	53
NFC	62
Noise level.....	76

O

Opening the bed base.....	60
Operating altitude	16
Operating overview	34
Operator's obligations	14
Optical components (care)	50
Order numbers	78, 80

P

Packaging.....	19
Performance rights.....	20
Personnel training.....	14
Plastic surfaces (care)	49
Plug-in connector	15
Power.....	76
Preclusion of damage	28
PROFESSIONAL SETUP MANAGER PLUS.....	35
Prohibited usage.....	9
Protective glasses	10
Protective measures when performing maintenance work	47

R

Radiation area	44
Recycling	19
Remote SERVICE	53
Removing the canopy panel.....	58
Removing the side section panel.....	59
Replace the low-pressure lamps.....	63
Replacing the AQUA SYSTEM canister.....	75
Replacing the lamps	61
Restrictions	10
Risk of injury.....	32



S

Safety	15
Safety instructions	
Device-specific safety instructions	9
General safety instructions	14
Scope of delivery	14, 29
Service kit.....	56
Setup	15
Setup location.....	16
Showering	32
Size	77
Skin sensitivity	12
Skin type.....	12
Spare parts.....	53
Order numbers	80
SPECTRA LED boards (care)	50
Starting the tanning	41
Start-up adjustments.....	41
Storage.....	18
Sunburn	32
Symbols	7

T

Tanning times	13
Technical data	76
Time control.....	17
Transport.....	15

U

Unit description.....	30
UV exposure.....	10

V

Ventilation.....	15
Voice control.....	45
Volume	44