

Operating instructions

Translation of the original operating instructions

Spirit Pure Light

1032675-00B / en / 10.2024

Ergoline

Legal notice



Manufacturer: JK-Products GmbH
Köhlershohner Straße 60
53578 Windhagen
GERMANY
Tel: +49 (0) 22 24 / 818-0

Customer service / JK-International GmbH,
Technical service Division JK-Global Service
(Spare part orders Köhlershohner Straße 60
for components): 53578 Windhagen
GERMANY
Tel: +49 (0) 22 24 / 818-861

E-mail: service@jk-globalservice.de

Spare part orders for JK-International GmbH,
consumables: Division JK-Licht
Köhlershohner Straße 60
53578 Windhagen
GERMANY
Tel: +49 (0) 22 24 / 818-600

E-mail: info@jk-licht.de

DANGER!



Failure to observe these operating instructions:

- may result in serious injury and death,
- can result in damage to the unit and to the environment.
- Read these instructions carefully before putting this unit into operation.
- Please observe the instructions and the code of conduct required to operate the unit safely.
- Please make the operating instructions and additional information from the manufacturer available to the personnel at their workplace.
- Should you sell this unit or give it to another party, please make sure that you provide them with these operating instructions.

Copyright

The copyright remains with JK-Holding GmbH.

The contents may not be partially or completely duplicated, distributed or utilized for competitive purposes without authorization or disclosed to other parties.

The right to make technical changes in regard to the figures and information contained in these operating instructions is reserved!

Table of contents



| | | |
|--------|---------------------------------------|----|
| 1 | Safety instructions and warnings..... | 5 |
| 1.1 | General..... | 5 |
| 1.1.1 | Definitions..... | 5 |
| 1.1.2 | Symbol explanation..... | 6 |
| 1.2 | Intended use..... | 7 |
| 1.3 | Foreseeable misuse..... | 7 |
| 1.4 | Tanning safety information..... | 8 |
| 1.4.1 | Prohibited usage..... | 8 |
| 1.4.2 | Important notes..... | 9 |
| 1.4.3 | Skin type descriptions..... | 11 |
| 1.4.4 | Tanning times EN (UV type 2)..... | 12 |
| 1.5 | Safety instructions and warnings..... | 13 |
| 1.5.1 | Operator's obligations..... | 13 |
| 1.5.2 | Personnel training..... | 13 |
| 1.5.3 | Scope of delivery..... | 13 |
| 1.5.4 | Transport, assembly and setup..... | 13 |
| 1.5.5 | Commissioning..... | 16 |
| 1.5.6 | Operation and maintenance..... | 16 |
| 1.5.7 | Decommissioning..... | 17 |
| 1.5.8 | Storage..... | 17 |
| 1.5.9 | Disposal..... | 17 |
| 1.5.10 | Directives..... | 18 |
| 1.5.11 | Export..... | 18 |
| 1.5.12 | Own music..... | 19 |
| 1.5.13 | Technical modifications..... | 19 |
| 1.6 | Signs and stickers on the unit..... | 20 |
| 1.7 | Preclusion of damage..... | 25 |
| 1.8 | Exclusion of liability..... | 25 |
| 2 | Description..... | 26 |
| 2.1 | Scope of delivery..... | 26 |
| 2.1.1 | Options..... | 26 |
| 2.2 | Equipment..... | 26 |
| 2.3 | Unit description..... | 27 |
| 2.4 | Accessories (optional)..... | 28 |
| 2.5 | Functional description..... | 28 |



| | | |
|-------|---|----|
| 3 | Operation..... | 29 |
| 3.1 | User safety information | 29 |
| 3.2 | Tanning - but correctly! | 29 |
| 3.3 | Operating overview..... | 31 |
| 3.3.1 | SETUP MANAGER | 32 |
| 3.4 | Functions | 33 |
| 3.4.1 | Navigation..... | 33 |
| 3.5 | Start..... | 37 |
| 3.6 | Coupling with Bluetooth® devices | 37 |
| 3.7 | Listening to music..... | 39 |
| 4 | Cleaning and maintenance..... | 40 |
| 4.1 | Safety instructions when undertaking cleaning or maintenance work..... | 40 |
| 4.2 | Faults..... | 41 |
| 4.3 | Cleaning | 41 |
| 4.3.1 | Cleaning the surfaces | 42 |
| 4.3.2 | Lamps | 42 |
| 4.3.3 | SPECTRA LED Boards | 43 |
| 4.4 | Cleaning plan | 44 |
| 4.5 | Maintenance | 45 |
| 4.5.1 | Acrylic glass..... | 45 |
| 4.5.2 | REMOTE SERVICE (optional) | 46 |
| 4.6 | Maintenance plan..... | 46 |
| 4.7 | Cleaning and maintenance work preparation..... | 49 |
| 4.7.1 | Service kit..... | 49 |
| 4.7.2 | Lift up the acrylic glass panel and remove the partition..... | 49 |
| 4.7.3 | Remove the canopy panel..... | 51 |
| 4.7.4 | Removing the front panel..... | 53 |
| 4.8 | Instructions for replacing the lamps | 55 |
| 4.8.1 | Low-pressure lamps..... | 56 |
| 4.9 | Cleaning or replacing lamps in the base..... | 57 |
| 4.10 | Cleaning or replacing lamps in the canopy..... | 58 |
| 4.11 | Cleaning the filters in the base | 59 |
| 4.12 | Cleaning the canopy filter mats..... | 62 |
| 5 | Technical data | 63 |
| 5.1 | Power, connection rating and noise level | 63 |
| 5.2 | Dimensions | 64 |
| 5.3 | Lamp sets | 65 |
| 5.3.1 | Ergoline Spirit Pure Light..... | 65 |
| 5.4 | Spare parts and accessories | 66 |
| 6 | Appendix | 67 |
| 6.1 | JK timer controls | 67 |
| 6.2 | Equivalence key range..... | 67 |
| 6.2.1 | Description of the equivalence keys for fluorescent lamps..... | 68 |
| 7 | Index | 69 |

1 Safety instructions and warnings



To ensure safe operation of the device, it is necessary to read the following safety instructions and warnings carefully and comply with them.

These instructions should be retained for future use.

The safety instructions summarized here are repeated in the corresponding chapters, where necessary.

1.1 General

1.1.1 Definitions

Operator

Person who provides the devices described here to users on a commercial basis. The operator is responsible for the correct operation of the device as well as compliance with the maintenance intervals.

User

A person who uses the device at a commercial location.

Personnel

People who are responsible for the operation, cleaning and general maintenance work and who instruct the users in the operation of the devices.

Electrician

A person with suitable professional training, knowledge, experience and knowledge of the applicable regulations which enable them to identify and avoid the dangers which can arise from working with electricity.

Authorized, trained and qualified personnel

Qualified staff from an external company who have been trained and authorized by the manufacturer to undertake assembly and maintenance work on specific equipment.



1.1.2 Symbol explanation

The following types of safety notices are employed in these operating instructions:

 DANGER!



Type and source of hazard

This safety notice indicates the existence of a direct danger to body and life.

 DANGER!



Type and source of hazard

This safety notice warns of dangers to body and life which are caused by electricity.

 WARNING!



Type and source of hazard

This safety notice warns of machine, material or environmental damage.



NOTE:

This symbol does not identify any safety notices, but provides additional information to better understand the processes.

1.2 Intended use



This unit serves the purpose of cosmetic tanning for one adult person with skin suitable for tanning. More detailed information can also be found on pages 11 and 29.

This device is intended only for commercial use and not for private use.

Some people are not permitted to use the device, see page 8.

The device may not be used by people with reduced physical, sensory or mental capabilities or who have insufficient experience and/or knowledge without supervision. A person responsible for their safety must ensure, either by supervision or instruction, that the device is used correctly and safely. If there is any doubt, use of the device by such categories of persons is to be forbidden!

The device may only be operated with the specified or equivalent lamps. The tanning times given in this instruction manual are valid only for the specified lamp set.

Any other use shall be considered improper. The manufacturer cannot be held liable for damage or injuries resulting from this. The operator bears the sole risk for this.

Proper use also includes compliance with the manufacturer's instructions and its operating and maintenance conditions. The unit may only be operated, maintained and repaired by trained professionals familiar with this unit and who have been informed of the dangers involved.

1.3 Foreseeable misuse

The following uses of the device are explicitly prohibited:

- The device may not be used by several people at the same time. The acrylic glass panel may otherwise break and cause injuries.
- People with a body weight of more than 135 kg may not use the device. The acrylic glass panel may otherwise break and cause injuries.
- Exceeding the specified tanning times may result in burns and long-term skin damage.
- When the device is in use no other people may remain in the cabin, in particular no children.
- While using the device no pets may be present in the cabin.
- People under 18 years of age may not use the device.



1.4 Tanning safety information

1.4.1 Prohibited usage

 DANGER!



UV radiation

Danger of skin and eye injuries or skin diseases!

- Please observe the following instructions.

The following people may not use the device:

- People under 18 years of age
- People who cannot tan
- People who cannot tan in the sun without risking a sunburn
- People who easily sunburn when in the sun
- People with acute sunburn
- People who repeatedly suffered from serious sunburn during childhood
- People with naturally red hair
- People with atypically discoloured areas of skin
- People who have or have had skin cancer
- People who suffer from an increased risk of skin cancer (e.g. cases of skin cancer in the family)
- People among whose closest relatives a melanoma has occurred
- People who are being medically treated for photosensitivity
- People taking photosensitivity causing medicine
- People with freckles and people who tend to develop freckles
- People with more than 16 moles on their body (2 mm diameter or larger)
- People with atypical moles (atypical moles are, for example, asymmetrical moles with a diameter greater than 5 mm, with varying pigmentation and irregular edges)
- Seek medical advice without fail if in doubt!

The following people may only use the device after consultation with their doctor:

- People with chronic illnesses, in particular those related to the skin
- People with illnesses of the immune system / auto-immune diseases
- People with collagenosis (e. g. lupus erythematoses, scleroderma)
- People suffering from rosacea (copper rose)
- People with spider veins (e. g. couperose, Osler's disease, spider nevi)
- People with low blood pressure, cardiovascular diseases
- People suffering from venous diseases
- People suffering from cancer
- People with fresh wounds following an operation or surgery
- People with tattoos or piercings which have not fully healed
- Pregnant women



Should there be any doubt with regard to compatibility, despite no known medical side effects, a test application of a maximum of 5 minutes should be initially carried out and the reactions observed. If no adverse reactions are found after 48 hours, normal application may be begun.

1.4.2 Important notes

All other people must observe the following instructions:

Danger of skin and eye injuries or skin diseases!

- The skin can become sunburnt when exposed to excessive radiation. Excessive, frequently repeated UV radiation exposure from natural sunlight or UV devices can result in premature ageing of the skin and an increased risk of skin tumours.
- Particular caution is advisable for individuals who are especially sensitive to UV radiation, and when certain medicaments or cosmetics are used. Seek medical advice without fail if in doubt!
- Seek medical advice if any unexpected consequences, such as itching, occur within 48 hours of the first tanning session.
- Increasing tanning requires increased exposure time (= radiation time) or after a certain degree of tanning has been achieved, increased tanning is not possible. However, the radiation time may not be extended as desired within the scope of the permissible radiation doses! Therefore, only a certain level of final tanning, which depends on the skin type, can be achieved without endangering your health.
- The tanning unit must never be used when the housing is broken or damaged, or the timer is defective!

Behaviour before, during and after a sunbath:

- During the tanning session no other people may remain in the cabin, in particular no children.
- Remove all jewellery (including piercings) before the tanning session.
- Remove cosmetics before tanning and do not use sun screen products.



- Do not use any products intended to accelerate tanning.
- UV light can cause irreversible skin or eye damage. The unprotected eye can become inflamed on the surface, and in certain cases the retina can be damaged by excessive radiation. Cataracts can form after numerous repeated tanning sessions. Use the UV-impermeable protective goggles provided (order no. 1027211-..). Contact lenses and sun glasses are no substitutes for protective glasses.
- Protect sensitive skin areas such as scars, tattoos and genitals before tanning.
- Observe the recommended tanning times.
- During a tanning session the quantity of radiation which results in the skin reddening (MED, minimum erythema dose) may not be exceeded. If reddened skin occurs around 16-24 hours after the tanning session you may not use the tanning device again for one week. After one week you can start again from the beginning with the first tanning session in accordance with the tanning table.
- The time between the first two sessions on the sunbed must be at least 48 hours! Do not take an additional sunbath on the same day.
- See a doctor if stubborn swelling, sores or pigmented moles form on the skin.

1.4.3 Skin type descriptions

 DANGER!



Burns and long-term damage!

People with skin type I may not use the tanning device.

The following applies to people with skin types II, III and IV:

- Observe the tanning times.
- Observe the safety instructions.





NOTE:

The tanning times are only valid for the lamp set specified on the lamp set sticker.

The tanning sessions should be at least 48 hours apart.

The maximum dosage of 25 kJ/m² per year should not be exceeded.

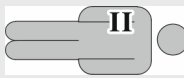
The maximum dosage is weighted according to NMSC.¹

| Skin type I | Skin type II | Skin type III | Skin type IV |
|---|--|---|---|
|  |  |  |  |
| Sensitive skin | Light skin | Normal skin | Dark skin |
| Always/frequently burns | Usually burns | Sometimes burns | Rarely burns |
| Tolerates only a small amount of natural sun. | Tolerates approx. 10-20 min. of natural sun. | Tolerates approx. 20-30 min. of natural sun. | Tolerates approx. 40 min. of natural sun. |

¹ NMSC: Non Melanoma Skin Cancer



1.4.4 Tanning times EN (UV type 2)



NOTICE:

People with skin type I should not use the device.

- Observe the tanning times

Observe the national requirements!

The tanning dosage of 3 kJ/m² per programme of tanning sessions should not be exceeded.

The maximum tanning time must not exceed 33.

The tanning sessions must be at least 48 hours apart.

The maximum tanning minutes per year should not exceed 833 minutes.

Ergoline Spirit Pure Light

- UV low-pressure lamps ERGOLINE TREND ADVANCED 100 W R E6 1509050-..
- UV low-pressure lamps ERGOLINE TREND DIRECT R31 160 W CS 1023987-..
- UV low-pressure lamps ERGOLINE TREND 8 W E27 1517170-..

| Number of tanning sessions | Skin type I | Skin type II | Skin type III | Skin type IV |
|----------------------------|-------------|--------------|---------------|--------------|
| | [min] | [min] | [min] | [min] |
| 1 | – | 5 | 5 | 5 |
| 2 | – | 11 | 11 | 11 |
| 3 | – | 13 | 13 | 13 |
| 4 | – | 13 | 13 | 13 |
| 5 | – | 16 | 16 | 16 |
| 6 | – | 16 | 16 | 16 |
| 7 | – | 20 | 20 | 20 |
| 8 | – | 22 | 22 | 22 |
| 9 | – | 25 | 25 | 25 |
| 10 | – | 25 | 25 | 25 |



NOTICE:

According to standard EN 60335-2-27:2013 the tanning table is not depending on skin types.

Identical tanning times are valid for all skin types, with the exception of skin type I.

1.5 Safety instructions and warnings



1.5.1 Operator's obligations

As the operator you are responsible for providing clear operating, cleaning and maintenance instructions and ensuring the intended use and the proper operation of the unit by means of training and instruction for the personnel.

Your operating instructions must enable the safe use and safe operation of the unit and take into account the characteristics and expertise of your company and also the national work safety and environmental protection regulations (within the European Union, the EU directive 89/391/EEC).

1.5.2 Personnel training

As the operator you are obliged to train your personnel and instruct them in the established legal and accident prevention regulations. Ensure that your personnel have understood and observe these operating instructions. This applies in particular to the

- information in 'Intended use' and 'Foreseeable misuse'
 - safety instructions in the 'Operation' chapter
 - operating instructions
 - cleaning and maintenance instructions
- Please make the instructions and additional information from the manufacturer available to the personnel at their workplace.
 - Regularly check your personnel's safety consciousness and awareness of the risks, taking into account your operating instructions.
 - Please ensure that the cleaning intervals are complied with, in particular cleaning after every tanning session.
 - Please ensure that your personnel provide your customers with appropriate advice, in particular regarding tanning times, possible risks and the operation of the device.
 - People under 18 may not use the device. Please instruct your personnel to check the customer's identification in the event of doubt.

1.5.3 Scope of delivery

Information regarding the scope of delivery is contained in the 'Description' chapter on page 26.

1.5.4 Transport, assembly and setup

The device is delivered by a specialist company and assembled and set up by the manufacturer's own service personnel or by an authorized service company.

As an operator you are responsible for complying with the on-site ventilation and electrical requirements at the setup location, see page 14.



Assembly

DANGER!



- Personal danger due to electric shock or burns!
- The assembly and electrical connection must comply with the national regulations.
 - The on-site electrical installation must be fitted with an easily accessible all-pole isolating device (master switch), complying with overvoltage category III. This means that each pole must have a contact opening width complying with the conditions of overvoltage category III for full isolation.
 - If the connection is established via a plug-in connection then the connection system according to EN 60309 must be utilized.
 - Assembly, installation, upgrading or repair of the device may only be carried out by specially trained and authorized personnel.
-

Information regarding the disassembly and assembly of the device is available in the separate assembly instructions. These assembly instructions are intended solely for use by the manufacturer's service personnel or by qualified specialists authorized by the manufacturer.

Ventilation

WARNING!



- Risk of overheating due to air flow problems!
Operating faults possible.
- Do not change, obstruct or block the air inflow and outflow area to the unit or make any unauthorized changes to the unit. The manufacturer shall bear no liability for damage or injuries resulting from such actions.
 - Observe the ventilation system data.
 - Do not set up and operate the device on the transport pallet!
-

You can obtain data regarding the air supply and ventilation from the customer service department (see page 2).

Setup location

WARNING!



Salty air! Contaminated air!

Device damage due to corrosion of the housing and electrical components.

- Do not set up the unit at a swimming pool.
- Do not operate the device in locations with aggressive environmental conditions (e.g. air containing chlorine).

Damage to unit possible!

Where there are great differences in temperature between the transport route and the installation site the unit may not be put into operation immediately after being set up.

- Wait at least 2 hours before connecting the unit to the power supply.

Risk of overheating due to air flow problems!

Operating faults possible.

- Do not change, obstruct or block the air inflow and outflow area to the unit or make any unauthorized changes to the unit. The manufacturer shall bear no liability for damage or injuries resulting from such actions.
- Observe the ventilation system data.
- Do not set up and operate the device on the transport pallet!

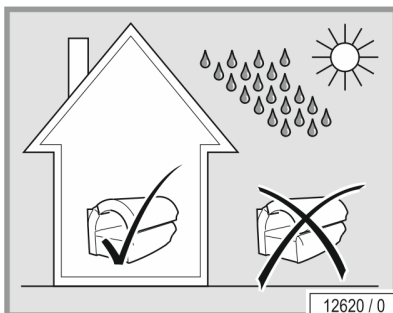
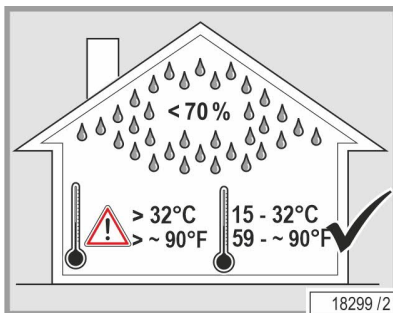

Environmental conditions

- Optimum ambient temperature: Between +15°C and +32°C
- Storage temperature: Between -15 °C and +60 °C

Possible damage to the unit!

The unit is not to be used outdoors.

Keep the unit away from open flames or sources of ignition.

Adaptation of the unit is required for operating altitudes greater than 2000 m above sea level in order to guarantee trouble-free operation.

The device is not suitable for operation in mobile facilities (ships, buses, trains). Adaptation of the unit is required in order to guarantee trouble-free operation when used in mobile facilities.

Please contact the Customer service department without fail before putting the unit into operation - see page 2.



1.5.5 Commissioning

 DANGER!



Damaged mains power cable!
Danger to persons through electric shock or burns.
- Only the manufacturer or specialist companies are permitted to replace the mains power cable.

Initial commissioning will be undertaken by the manufacturer's own service personnel or by an authorized service company. The device will be handed over ready for use.

If the device has not been used for a longer period of time, then it must first be inspected by our customer service department or by another authorized company before being put back into operation again.

The device is operated with an external time-control unit.

A time control unit must be attached so that the device automatically switches off at the latest after <110 % of the selected running time even if the controller fails. The device running time must be secured with a timer control that complies with the standard EN 60335-2-27).

Dependent on the local power supply company, the devices can transmit interference to the power system of the building that impair the audio-frequency remote control system used by the power supply company. This can, for example, interfere with the function of night-storage heaters.

If faults occur due to the operation of the devices, then the operator is responsible for the installation of an audio frequency blocking device in the building electrical installation. Please contact your electrician. The electrician is familiar with the technical connection conditions of your local utility company so that the audio-frequency blocking device can be matched to the power system of your power supply company.

1.5.6 Operation and maintenance

Error-free operation, maintenance and service are required in order to ensure that the health and safety of the users is not endangered during operation and to ensure that the device is in a fault-free operating condition.

Please observe the information and recommendations provided in these operating instructions. Please ensure that the intervals for the inspection, maintenance and service are complied with. Please ensure that the lamps are replaced after the specified usage time.

Unauthorized modifications and changes to the device and its control unit are prohibited. Failure to comply with this invalidates the operating licence!

To avoid hazards, the device must not be used if the mains power cable is damaged. A damaged mains power cable must be replaced by the manufacturer or their customer services, or by trained and qualified specialist personnel.

**NOTE:**

If a fire is suspected, immediately disconnect the power supply as long as this is safely possible. Continue to observe all regulations required by law, public authorities and employer's liability insurance associations, which remain unaffected by the aforementioned instructions.



1.5.7 Decommissioning

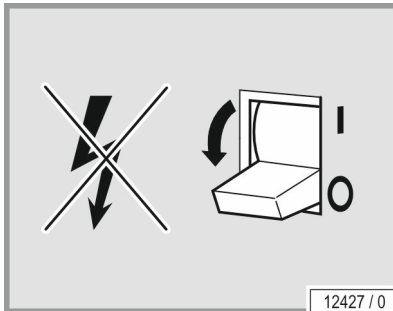

The device must be disconnected from the power supply in order to temporarily or permanently decommission it.

You must abide by the legal disposal requirements when permanently decommissioning the device.

1.5.8 Storage

Store the devices in a dry location with a stable temperature. Once the device has cooled off, pack it in plastic wrapping to protect it against scratches.

- Storage temperature: Between -15 °C and +60 °C

1.5.9 Disposal

Environmental regulations – disposal of lamps and batteries

Lamps contain fluorescent materials and other waste containing mercury. Batteries contain heavy metal compounds.

Within the European Union the national implementation of the Waste Framework Directive 2018/851/EG applies. According to the national waste disposal laws and in accordance with the municipal waste regulations, proof must be provided of the proper disposal of lamps and batteries.

Your local sales agency will be happy to assist you with the disposal of lamps and batteries:

- Inform your local agency of the number of lamps and batteries by telephone or in writing.

The agency will then provide you with the name of a free delivery point for your lamps or will take care, in conjunction with a disposal company, of the collection and proper disposal of the lamps. This service is available for a fee. Outside Germany, the respective national legislation applies. Please contact your local sales agency.

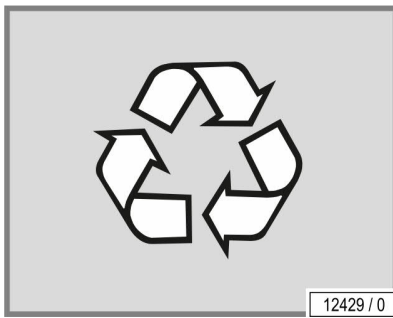

Packaging

All packaging consists of 100 % recyclable materials. Packaging brought into circulation by the JK Corporate Group that is no longer required can be returned to the JK Corporate Group. Your partner agency or dealer will be happy to advise.

Disposal of old units

The unit has been manufactured using recyclable materials. The JK Corporate Group will provide you with information on the content or potential hazards of the materials used.

The manufacturer is obliged to take back and dispose of certain electrical and electronic components in accordance with the 2012/19/EC Directive.

The components and units are labelled with the following symbol:

The unit will, if requested, be properly disposed of by the JK Corporate Group. This service is available free of charge. Your partner agency or dealer will be happy to advise.

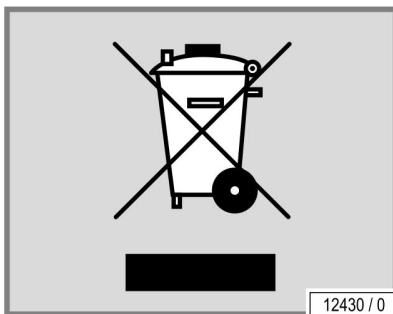

Registration numbers

Companies within the JK Corporate Group are registered as manufacturers in Germany and accept all obligations in respect of the German Electrical and Electronic Equipment Act.

Registry number JK-International GmbH, division JK-Licht GmbH (lamps):

WEEE-DE 61515020

Registry number JK-Products GmbH (Devices):

WEEE-DE 62655951

1.5.10 Directives

See the included EC Declaration of Conformity.

1.5.11 Export

We emphasize that these units are only intended for the European market and must not be exported to or operated in other countries e.g. the USA or Canada! The manufacturer does not accept any liability in the event of non-observance! We explicitly emphasize that non-compliance may result in high liability risks for the exporter and/or the operator.

1.5.12 Own music



1004450

11416 / 1



If a private smartphone is used during a session, this is not classed as public playback under copyright law, meaning that the studio's operator is not subject to any reporting or payment obligations vis-a-vis the organisation responsible for granting commercial performance rights.

For the public use of MP3 music files, the same regulations apply as for other sources of music: As the owner/operator of the studio, you are only permitted to play original audio files on your premises and/or in the "MP3 music module" included in JK International GmbH units if you have acquired the performance rights required for this purpose. You can obtain these rights from the organisation responsible for granting commercial performance rights in your country (in Germany: GEMA/GVL).

Copyright-protected audio files and the tracks included on these sound storage media may not be converted into MP3 format and/or stored on HDDs, audio CDs, MCs, audio DVDs, etc., if the conversion/storage process uses software that invalidates or bypasses the copyright protection included on the sound or data storage media.

You must be ready at any time to prove your granting of stage rights by presentation of the appropriate stage rights certificate when requested by a representative or another controlling body of the responsible organisation.

Provided that you have complied with all the information above and acquired the rights required for using the "MP3 music module", you can also convert your original audio files into the MP3 format required for the playback device. However, only one copy (duplicate or copy converted into MP3 format) may be produced of each legally acquired audio file. The source media (original sound storage media) must be kept and may not be used simultaneously.

Further details can be found in the information brochure 'Audio Guide' available on the Internet at <http://www.jk-globalservice.de>.



NOTE:

Pre-recorded SD cards which are delivered as accessories for a JK audio system are also subject to payment obligation for commercial usage.

1.5.13 Technical modifications

The device has been constructed in accordance with the current state of the art and the applicable safety regulations. The illustrations and specifications in these operation instructions are subject to technical modifications which are required in order to improve the device.

Unauthorized modifications and changes to the device and its control unit are prohibited. Failure to comply with this invalidates the EC conformity!

Please use only original spare parts. Failure to comply with this invalidates the EC conformity!



1.6 Signs and stickers on the unit

Danger area warning signs and important information about components are attached to the unit. The signs shown below are examples. Ensure that the warning signs are always clearly recognisable and legible. Any missing warning signs or stickers must be replaced.

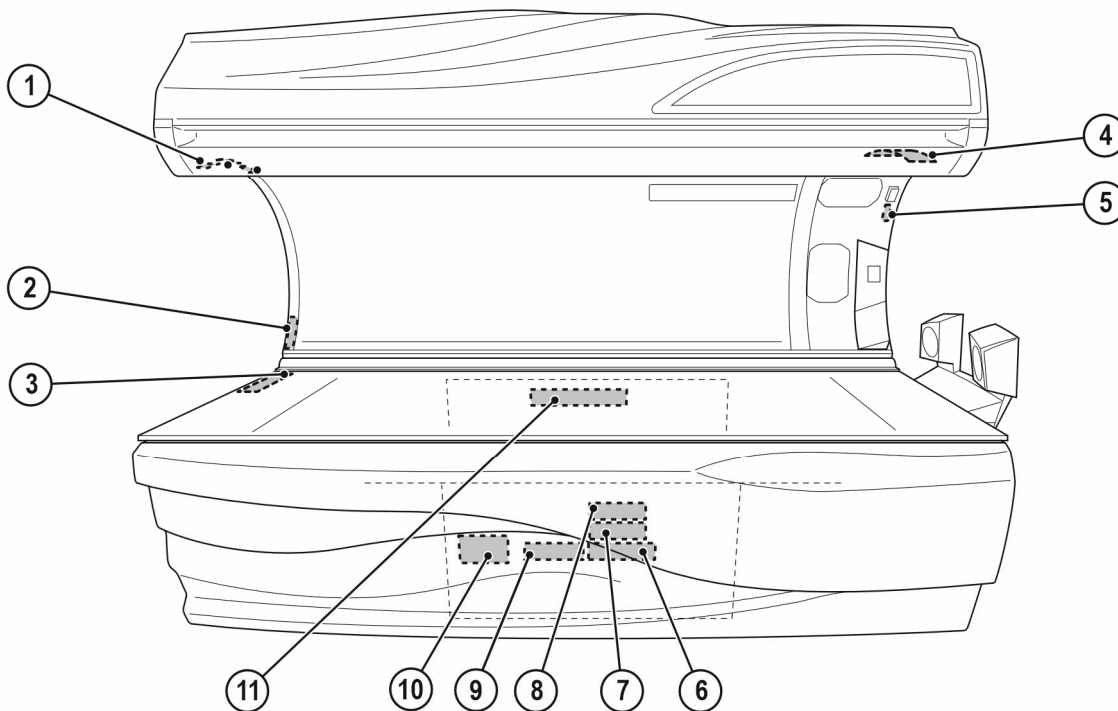

21314 / 0

1: Type plate

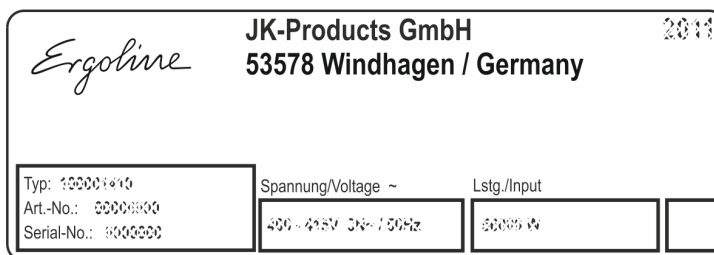

11991 / 2

The name plate is attached to the interior side of the canopy. It contains important information for identifying the device (e. g. the serial number = Serial-No.).

2: Maintenance instruction sticker (800701-..)

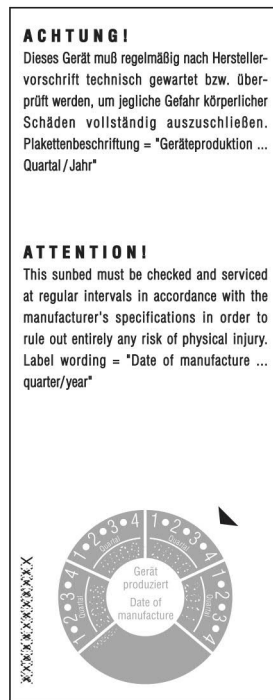

12225 / 1

The sticker is mounted at the foot end on the inside of the canopy.

3: Lamp set sticker

| | | | | | | |
|--|---|-----|----|----|--|----------------------------------|
| | | | | | Ergoline ESPRIT 770-S DYNAMIC POWER | |
| | ① | 18x | | | Ergoline TREND 80-200 W E5 | 1504180- |
| | ② | 8x | | | Ergoline TREND 80-200 W E5 | 1504180- |
| | ③ | 22x | | | Ergoline TREND 80-200 W E5 | 1504180- |
| | ④ | | 8x | 2x | Ergoline ULTRA 520 W ULTRA PERFORMANCE 862 | 1504180- 1504180- |
| | | 3x | | 2x | ULTRA PERFORMANCE 862 Ergoline TREND 8 W E5 | 1504180- 1504180- |
| | ⑤ | - | - | - | Ergoline TREND 80-200 W E5 | - |
| EIN EN 60598-2-27, spec. Exe 0,3 200W | ⑥ | | 2x | 2x | Ergoline ULTRA 100 W ULTRA PERFORMANCE 862 GLASS/ASSIVERPFL. | 1504180- 1504180- 1504180- |
| JK-Products GmbH / GERMANY | | | | | 1003066-01 | |

12846 / 0

The precise details of the required lamps are available in the separate appendix.



4: EU warning sticker (1012638-..)



This sticker also includes the language form 1504231-.. (see accessories Technical Documentation).

5: Emergency off sticker (1512131-..)



The sticker is mounted at the head end on the inside of the canopy. This sticker also includes the language form 1018688-.. (see Technical Documentation folder).

6: ESD (Electrostatic discharge) - sensitive components sticker (85662-..)

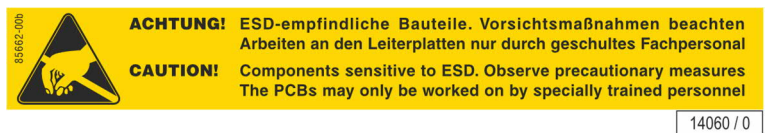

This sticker is mounted in several places in the device.

7: 'No export USA/Canada' sticker (84829-..)

| HINWEIS | NOTE | REMARQUE |
|---|--|--|
| Wir weisen darauf hin, daß die Geräte nicht in die USA oder nach Kanada exportiert und dort betrieben werden dürfen. Bei Nichtbeachtung dieses Hinweises wird keine Haftung übernommen. | We emphasize that these devices must not be exported to or operated in the USA or Canada! The manufacturer does not accept any liability in case of non-observance of this notice! | Nous attirons votre attention sur le fait que les appareils ne doivent pas être exportés ni utilisés aux Etats-Unis ou au Canada! Nous ne pourrions nullement être tenus responsables de dommages si cette remarque n'est pas respectée! |



11977 / 2

The sticker is mounted on the controller support.

8: 'Not disconnected from power supply' warning sticker (800698-..)

GEFAHR
Bei geöffnetem Gerät nicht spannungsfrei!

DANGER
Voltage is not switched off, when sunbed is opened.

800698b

21313 / 0

9: 'Lock control box' sticker 1032324-..

Sicherheitshinweis:
Zum störungsfreien Gerätebetrieb muß der Steuerboxdeckel immer ordnungsgemäß verschlossen sein!

Note on safety:
The control box cover must always be properly closed on for fault-free device operation!

21312 / 0

1: Note! Only genuine parts (800702-..)!

Hinweis !

Verwenden Sie in diesem Gerät ausschließlich Original-JK-Ersatzteile.
Bei Schäden, die nachweislich durch die Verwendung von nicht Original-Ersatzteilen entstanden sind, wird jegliche Haftung ausgeschlossen.
Eigenmächtige Umbauten und Veränderungen am Gerät oder an der Steuerung sind nicht gestattet.
Bei Missachtung erlischt die Betriebserlaubnis!
Des Weiteren erlischt unsere EU-Konformitätserklärung (CE-Kennzeichen).

Note !

Please use only original JK spare parts in this device.
Any liability for damage or injury proven to be the result of the use of non-genuine spare parts is excluded.
Unauthorized modifications and changes to the device and its control unit are prohibited.
Failure to comply with this voids the operating licence!
In addition, our EU Declaration of Conformity (CE certification) shall also be voided.

JK Teile Nr.: 800702-01

21311 / 0

The sticker is mounted on the controller support.



10: 'Remove lattice' sticker (842971-..)

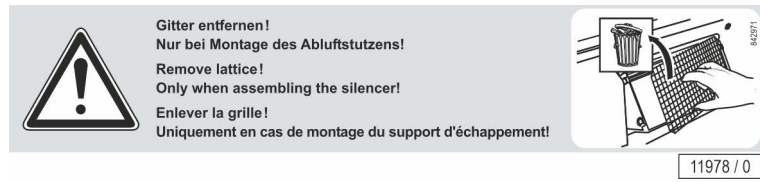

The sticker is mounted at the top of the rear panel.

1.7 Preclusion of damage



Insofar as the customer asserts any rights related to a defect in the unit based on the legal warranty and/or guarantee, the following shall apply:

The warranty and guarantee do not cover wear parts such as low-pressure lamps (tubes) or consumables (aroma) or acrylic glass panels.

Should the product contain faults, JK-International is entitled and obligated to repair or replace the product at its own discretion. Where it is not possible to repair or replace the product, the customer may withdraw from the purchase agreement or reduce the purchase price by a suitable amount.

The warranty period is two years from delivery or from acceptance, if an acceptance process is required. This does not affect the rights of the customer under the existing warranty with regard to any claims that the customer might have in accordance with the contract of purchase.

1.8 Exclusion of liability

Regardless of the legal grounds, liability of the JK Group shall be excluded if damage can be attributed to one or more of the following causes:

- improper use of the unit;
- improper assembly, commissioning, operation and maintenance of the unit;
- operating the unit with faulty safety equipment or improperly attached or non-functional safety and protective equipment including warning signs;
- not complying with the information in the operating instructions regarding transport, storage, setup, commissioning, operation and maintenance;
- the use of untrained personnel;
- unauthorized changes to the unit or the control unit;
- inadequate monitoring of parts subject to wear;
- repairs carried out improperly;
- the use of non-original spare parts;
- emergencies and disasters resulting from the influence of foreign materials or force majeure.

2 Description



2.1 Scope of delivery

- Tanning device
- Service kit: contains Allen key and suction cup
- Connecting lead
- Protective goggles
- Low-pressure lamps
- Technical documentation (operating instructions, error code brochures and SETUP MANAGER and other documents)

2.1.1 Options

- REMOTE SERVICE
- Central exhaust air socket
- Stereo sound system

2.2 Equipment

The unit's equipment may vary depending on its type.

This description takes into account all standard and optional components/functions, which must be observed during operation and/or maintenance.

2.3 Unit description

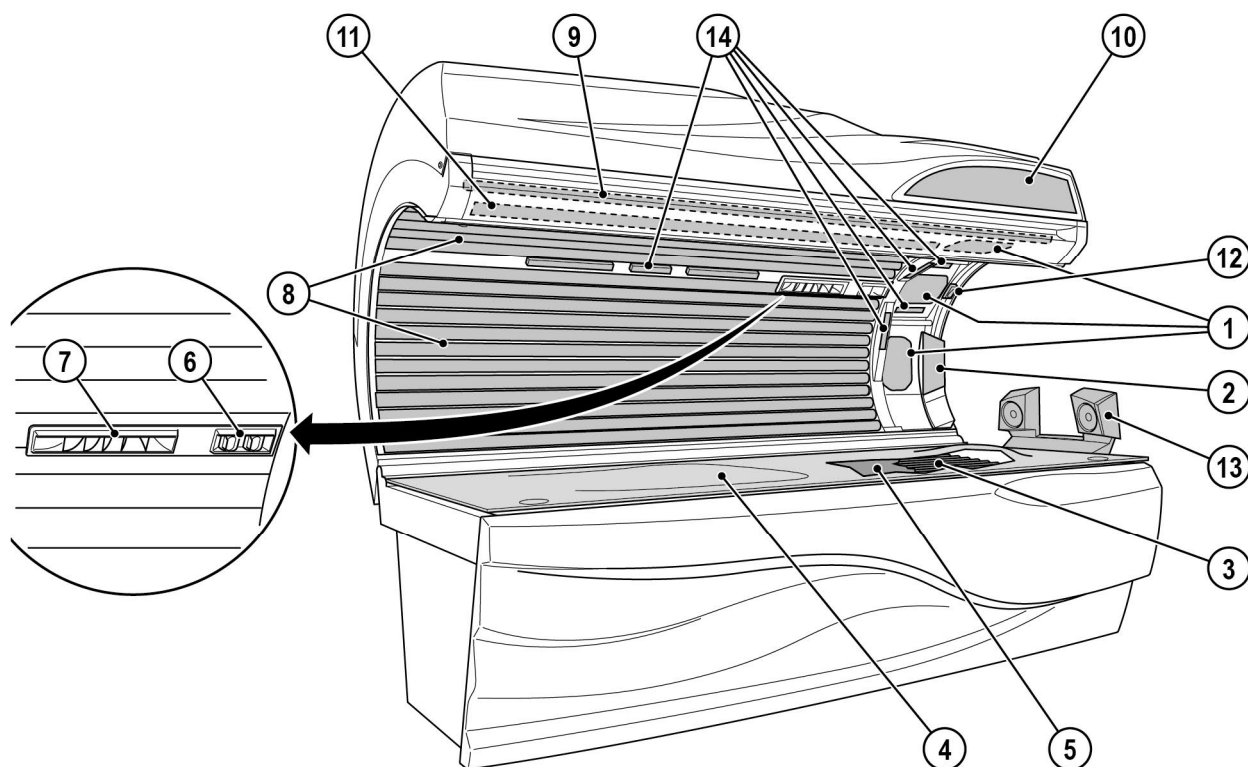

21206 / 0

1. Facial tanner (SPECTRA LED boards + low-pressure lamps)
2. EASY CONTROL
3. Low pressure lamps, base
4. Acrylic panel base
5. Partition
6. Adjustable air nozzles – Facial cooling
7. Body cooling air nozzles
8. Low pressure lamps, canopy
9. INTERIOR illumination (LED)
10. Exterior design illumination (LED)
11. Canopy handle illumination (LED)
12. EMERGENCY OFF button
13. Stereo sound with voice guide and Bluetooth® (optional)
14. Not applicable for this device.



2.4 Accessories (optional)

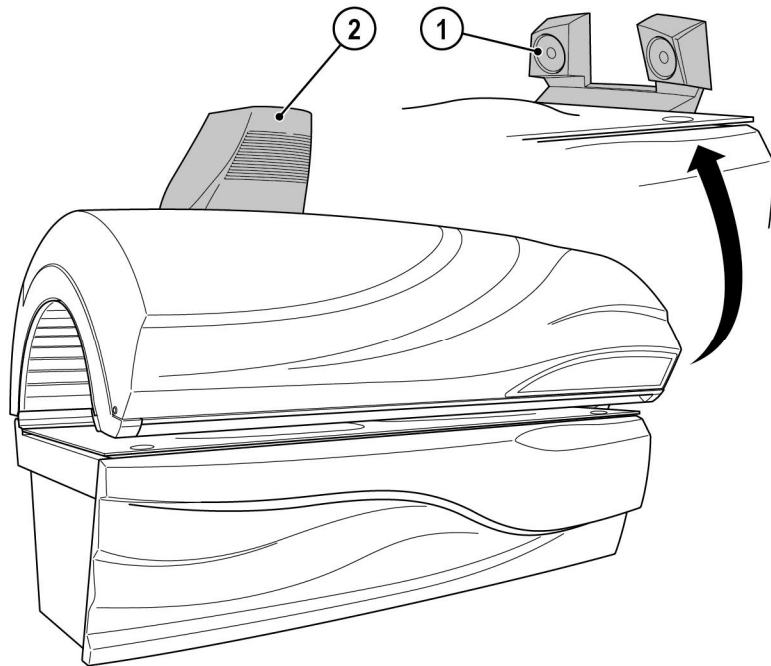

21309 / 0

1. Central exhaust air socket (optional)
2. Stereo sound system

2.5 Functional description

The primary technical components of a solarium are an artificial source of UV radiation and a mechanical structure with a defined usage area.

The UV spectrum is generated by low-pressure lamps and UV LEDs. In the face area, the dimmable ERGOLINE SPECTRA UV LED board ensures an outstanding tanning performance thanks to the combination of UV LEDs and spaghetti lamps.

3 Operation



3.1 User safety information

 **DANGER!**



UV radiation

Danger of skin and eye injuries or skin diseases!

- Please observe the safety instructions and warnings in chapter 1.

Danger of hearing damage!

Using earphones or headphones at high volume can result in permanent hearing damage.

- Do not set the volume too high.

3.2 Tanning - but correctly!

A few things need to be noted in order to obtain maximum enjoyment from a tanning unit. Here are some answers to frequently asked questions.

Make-up on the sunbed?

A wide variety of materials is found in cosmetics. Whether these are emulsifiers, greases, or fragrances – in conjunction with UV radiation, these can cause skin allergy reactions.

For this reason, always use cosmetics that have been specially developed for use in tanning booths.

So, this to-do list is a must before using a tanning unit: Remove all make-up. This is essential. Make-up clogs the pores in the face. The UV light from a tanning unit re-opens these clogged pores so that not only does the light penetrate the skin, but also the allergenic components of the make-up.

A further negative consequence of make-up is that the appearance of the skin deteriorates irreversibly over a period of time. However good decent make-up looks - in conjunction with UV light, it causes more harm than good. Therefore: Remove all make-up before a session on your sunbed - it will be much better applied afterwards.

Showering after leaving the sunbed?

The browning is in the skin, not on it. Therefore you cannot wash it off. Treat your skin to a moisturizing cream after showering.

Are medications and the sunbed compatible?

It is known that some medicaments increase the skin's sensitivity to UV light. This probability is particularly high with antibiotics, sulphonamides, psychiatric drugs, tranquillizers, anti-diabetes treatments and diuretics. Sun creams which contain psorale or kumarin also increase skin sensitivity. If you are in any doubt, first ask your doctor - then you can enjoy the sun at no risk.



Contact lenses on the sunbed?

The answer is: Yes! Like any other tanning unit user, contact lens wearers should also wear special protective goggles which protect the eyes against UV radiation. To guarantee better protection, wearers of spectacles and contact lenses can ask their optician for exchange contact lenses with UV protection. The UV-A and UV-B filters built into exchange contact lenses will protect the cornea and the internal parts of the eye against almost 100 % of the energy in UV radiation.

This will benefit tanning unit users not only in the open air, but on the tanning unit itself. You can wear these contact lenses on the tanning unit without any restrictions. For more information, ask your optician or optometrist.

3.3 Operating overview

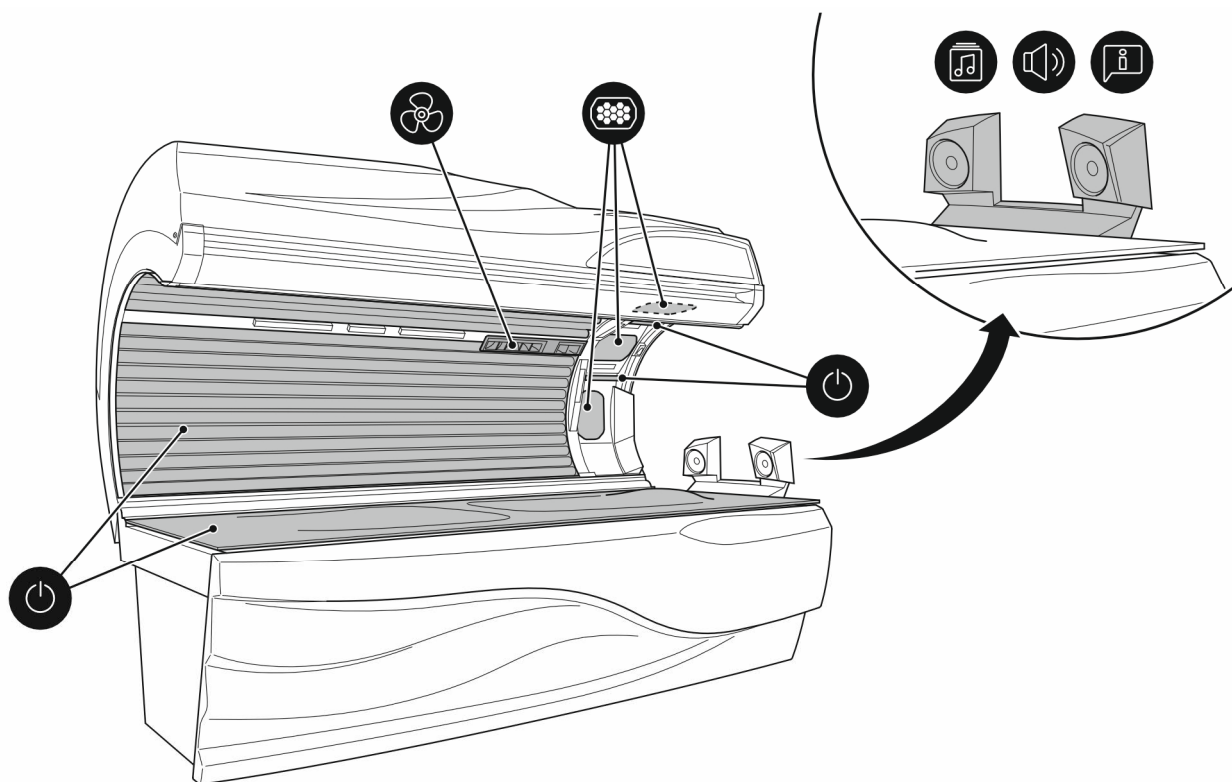

21319 / 0



During the tanning session, functions may be activated or deactivated via the EASY CONTROL. See chapter 12.6.

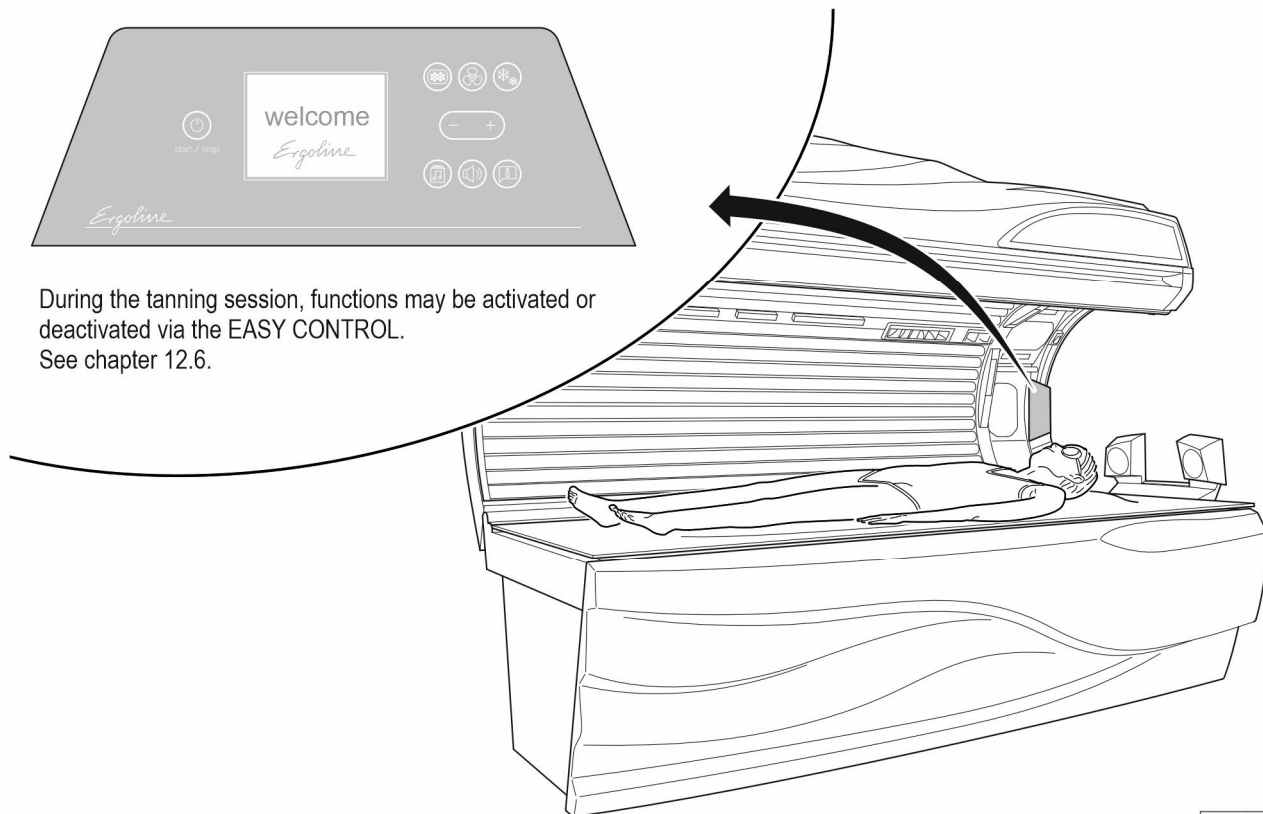

21212 / 0



3.3.1 SETUP MANAGER

In SETUP MANAGER, operating states can be called up and pre-settings entered.



NOTE:

The pre-settings mode can only be accessed when no tanning session is active.

30 seconds after the last button was pressed, the unit changes automatically into standby mode.

After making changes, each amended value must be saved with the Start/Stop button.



NOTE:

To access SETUP MANAGER, press the  button in standby mode.

On the control element:

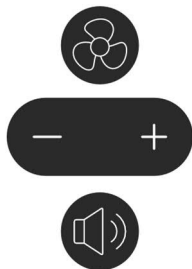

Select unit information on the directional pad



Activate, deactivate or change functions or settings on the directional pad.

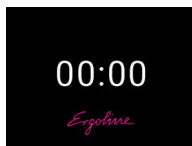

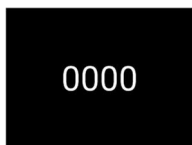

Start screen



SETUP MANAGER (Pre-setting mode)

Press  for approx. 3 seconds to open the SETUP MANAGER.

Use   to select the position of the entry.

Factory master code setting: 1000



NOTE:

Example '1000': Press  three times and  once.

Example '0001': Press  zero times and  once.

If the master code is entered correctly, the system switches directly to the SETUP MANAGER menu.



NOTE:

Further information on the SETUP MANAGER is available in the 'SETUP MANAGER' brochure, order no. 1032680-... (see: Technical Documentation).

3.4 Functions

3.4.1 Navigation

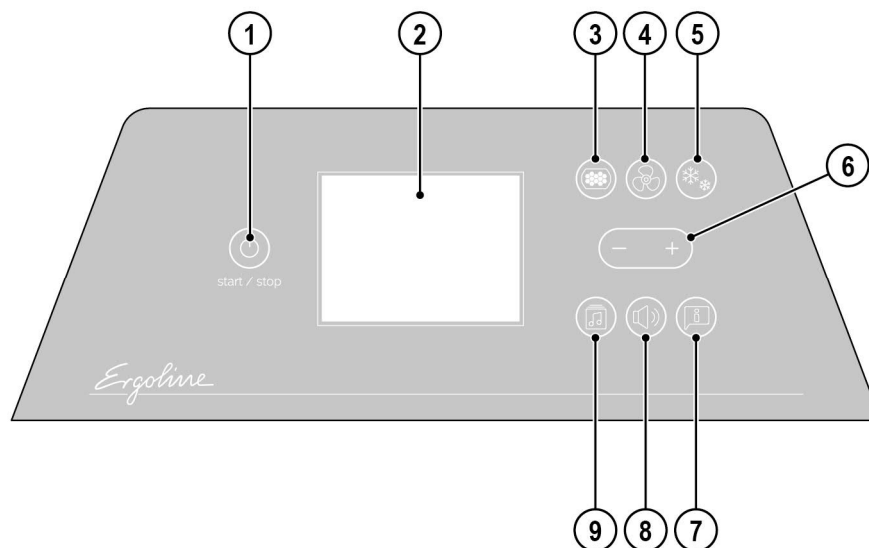

21214 / 0

1. START/STOP button
2. Display – Functions ...
3. Icon: SPECTRA LED boards, facial tanner
4. Body cooling/facial cooling pictogram
5. Not applicable for this device.
6. Plus/Minus button
7. Voice Guide pictogram
8. Volume pictogram
9. Audio source pictogram

EASY CONTROL

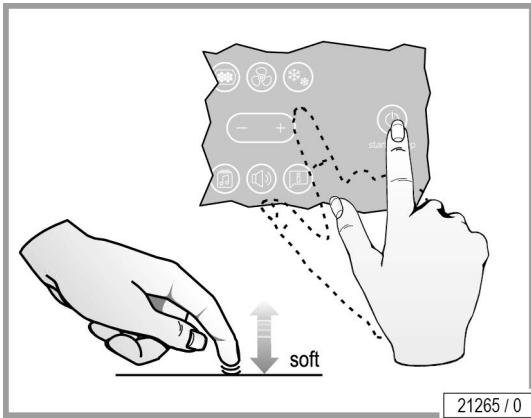

The EASY CONTROL provides convenient access to the unit function.

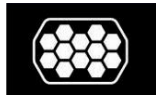

Confirm the selection.



Change the unit function parameters.















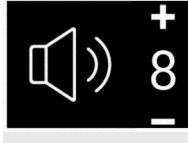
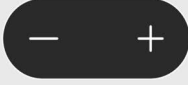

Start/Stop

Further information about 'SETUP MANAGER' 1032680-.. can be found in the technical documentation.

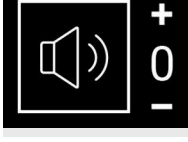

NOTE:

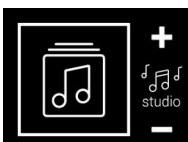
If no buttons have been pressed after 8 seconds, the settings return to default mode.

| Icon selection/ Key sequence | Navigation | Description/ Display | Information |
|---|---|--|---|
|  |  | START Switch the lamps on and off during the tanning session. The process is interrupted. | The tanning time continues to run if the lamps are switched off during a tanning session. |
|  |  | Control the body fan: Levels 0–8 | This function can be changed using these buttons  . |
|  | | | |
|  |  | Control the volume: Levels 0–8 | This function can be changed using these buttons  . |
|  | | | |
|  |  | Select the audio system SD card: Press the plus or minus button | During a tanning session, the  buttons can be used to select tracks for the internal music. You are unable to select different music folders on the SD card. |
|  | | Select studio channels: Press the plus or minus button | |
|  | | Select your own music via Bluetooth®: Press the plus or minus button | |
|  | | Switch off the audio system: Press the minus button | |





| Icon selection/ Key sequence | Navigation | Description/ Display | Information |
|---------------------------------|-------------------|--|--|
| | | Switch off the VOICE GUIDE: Press the minus button | The VOICE GUIDE gives acoustic guidance when operating the unit and it can only be used in conjunction with the audio system. The VOICE GUIDE is switched on by default when ready for operation and during tanning. |
| | | Switch on the VOICE GUIDE: Press the plus or minus button | The VOICE GUIDE leads the user through the entire operating process. This function can be switched on and off at any time. |
| | | Control the SPECTRA LED boards: Levels 0–2 | |
| | | | |
| EMERGENCY OFF | EMERGENCY OFF | EMERGENCY OFF | In standby mode, the EMERGENCY OFF button has no function. When the EMERGENCY OFF button is operated, the entire unit apart from the EASY CONTROL switches off. In this state, a display appears to show that the EMERGENCY OFF button has been operated. The tanning time is over. The VOICE GUIDE leads the user through the EMERGENCY OFF function. After being blocked for 2 seconds, the EMERGENCY OFF can be reversed again. The unit restarts in tanning mode. |
| | | | |
| | | After the fan run-on period: Clean the unit and then press the START/STOP button. The unit is then ready to be used again. | |
| | | | |

3.5 Start

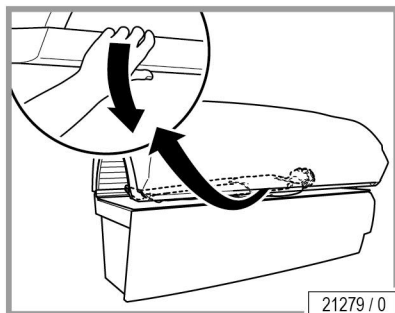

- Closing the canopy.
- Press the START/STOP button.

Upon starting the following functions are switched on:

- Lamps and LEDs
- Body cooling
- Facial cooling
- Stereo sound system
- VOICE GUIDE

3.6 Coupling with Bluetooth® devices

 **DANGER!**



Danger of hearing damage!

Listening to music at a high volume can result in permanent hearing damage.

- Do not set the volume too high.

Users can pair their personal smartphone with the audio system. The devices must be paired before the tanning session starts.

The solarium and the user's personal smartphone can only be paired via Bluetooth®¹Connect. When using Bluetooth® Connect, the user can transfer their favourite music into the solarium wirelessly from their smartphone. Operation can be performed conveniently via the EASY CONTROL during the tanning session.



NOTE:

- Ergoline cannot guarantee full compatibility with all Bluetooth® devices.
- Before coupling a device with this system, read the user manual to find out more about the Bluetooth® compatibility.
- Make sure that the Bluetooth® function is activated on your device and that the device is visible for all other Bluetooth® devices.

¹ Communication system: Bluetooth® standard version 3.0, Version 2.1 and EDR; max. operating range: approx. 10 m; frequency range: 2.4 GHz range (2.4000 GHz - 2.4835 GHz); compatible Bluetooth profiles: A2DP, AVRCP; simultaneously supported devices (pairing): one device



Pairing with a Bluetooth® player

Activate the Bluetooth® function and search for Bluetooth® devices.

Activate the Bluetooth® function on the iPhone®:

iPhone®:

Settings → General → Bluetooth® → ON (search for units is started.)

Activate the Bluetooth® function on the Android® smartphone:

Android® smartphone:

Press the Bluetooth® symbol → SCAN (search for units is started.)



NOTE:

The tanning device can store a maximum of ten coupled Bluetooth® devices. In the event of recoupling the tanning device must first be deleted from the Bluetooth® device. The activation process must then be repeated.



Display on the smartphone

- Select the solarium's Bluetooth® Connect name, e.g.. Ergoline SPIRIT.



NOTE!

Bluetooth® Connect is activated at the factory.

3.7 Listening to music



DANGER!



Danger of hearing damage!

Listening to music at a high volume can result in permanent hearing damage.

- Do not set the volume too high.

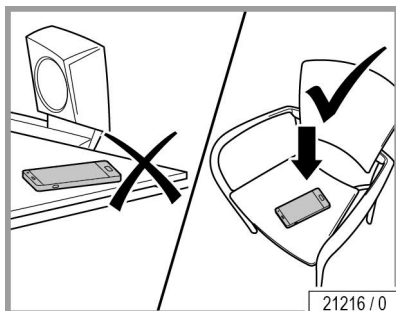

CAUTION!



Possible heat damage to the smartphone.

- Do not place the smartphone directly in the area of radiation.

4 Cleaning and maintenance



4.1 Safety instructions when undertaking cleaning or maintenance work

 **DANGER!**



Electricity throughout entire device!
Personnel danger due to electric shock or electric burns.

- Before beginning work, disconnect all of the power connections from mains voltage.
- Secure all of the disconnected connections against accidental reactivation.
- Check that the device is disconnected from mains voltage.
- All of the work and electrical connections must comply with the national regulations of the country in which the device is being operated (e.g. the VDE regulations in Germany) and must be undertaken by appropriately trained specialists.

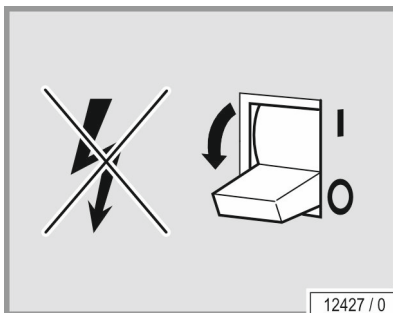

12427 / 0

If work is to be performed on the devices, they must be deenergized. That means that all live cables must be switched off.

Switching off the unit alone is insufficient, as certain points may remain energized. Therefore, switch off fuses before performing any work and – if possible – remove them.

Accidental reactivation can result in serious accidents. Immediately after deenergizing, secure all switches or fuses used for deenergizing against being switched on again.

- Lock the fuse box with a padlock.

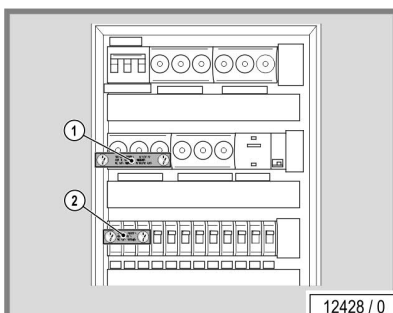

12428 / 0

In case of circuit breakers which cannot be unscrewed, a strip of adhesive tape may be applied over the actuation lever with the wording 'Do not switch, danger!' (1 + 2).

A prohibition sign with the text:

'Work in progress!'

'Place:'

'Sign may only be removed by:'

must always be securely mounted immediately.

4.2 Faults

Error codes are output to the display to simplify troubleshooting:

- If a fault occurs, an 'i' appears in the display. To see the error message, switch to the Setup Manager. This menu displays up to three error messages.
- The error is acknowledged by pressing the START/STOP button.
- If the error cannot be cleared, inform Customer Service – see page 2.

More detailed information regarding the error description and solutions can be found in 'Error Codes', (order no. 1019969-..).



4.3 Cleaning

 DANGER!



Infections can be spread by skin contact!

All objects/device parts that could come into contact with the user during tanning must be disinfected after every tanning session:

- Acrylic glass panel
- Handles and control panel
- Protective goggles
- Adjustable air nozzles

We recommend a suitable rapid surface disinfectant as a cleaning agent for rapid and thorough disinfection.



NOTE:

- To ensure thorough disinfection, always adhere to the contact time specified for the disinfectant. Follow the manufacturer's instructions for use.
- After the prescribed contact time, remove any remaining residues of the cleaning/disinfecting agents.
- Use a soft, clean single-use paper towel for this purpose.
- Carry out a visual inspection. Repeat the cleaning procedure if you find dirty areas or residues of the cleaning/disinfecting agent.
- Carry out a further visual inspection.



4.3.1 Cleaning the surfaces

Acrylic glass surfaces

 CAUTION!



Do not rub dry – danger of scratching!

Failure to observe this will invalidate all guarantee claims.

- Only use a rapid surface disinfectant for acrylic glass panels for fast, hygienic proper cleaning of acrylic glass surfaces.
- Do not use disinfectants or solvents (e.g. Lysoform, ethyl alcohol, or other fluids containing alcohol).

Acrylic glass panels unusable due to soiling!

Soiling on the panels is burned in by the hot lamps and results in the long term in unserviceable panels.

- Remove fingerprints, cleaning residues and other soiling carefully.

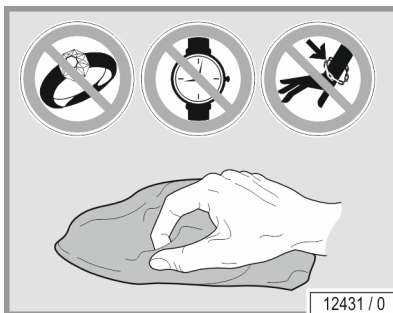

Plastic surfaces

To clean the painted and unpainted plastic surfaces, it is best to simply use warm water and a leather cloth. Never use alcohol-based aggressive cleaning agents or essential oils. These cause damage that is not covered by warranty claims.

During cleaning a slight discolouration of the leather cloth by the rubber seals must be expected for production-related reasons.

Prevent damage to the acrylic glass and plastic surfaces.

- Remove rings, watches, bracelets etc. before starting cleaning work.

4.3.2 Lamps

The lamps can be cleaned with a damp cloth and without additional cleaning agents where necessary.

4.3.3 SPECTRA LED Boards

 **CAUTION!**

SPECTRA LED boards are very sensitive optical components.

Risk of scratches!

Failure to observe this information will invalidate any warranty claims.



- Do not clean using mechanical equipment and do not clean with moisture!
- Do not spray the components!
- Do not buff or rub the components!
- Do not vacuum the components!
- If the components are dusty, use a clean, dry microfiber cloth.
- Only use the microfiber cloth for SPECTRA LED boards!
- Once used, clean the microfiber cloth according to the washing instructions for the cloth.
- Do not insert the microfiber cloth directly into the reflector clusters. Risk of scratches!
- Wipe the surface of the reflectors gently without applying any pressure!
- If the SPECTRA LED boards need to be cleaned mechanically (buffed), always contact Customer Service before cleaning – see page 2.

4.4 Cleaning plan

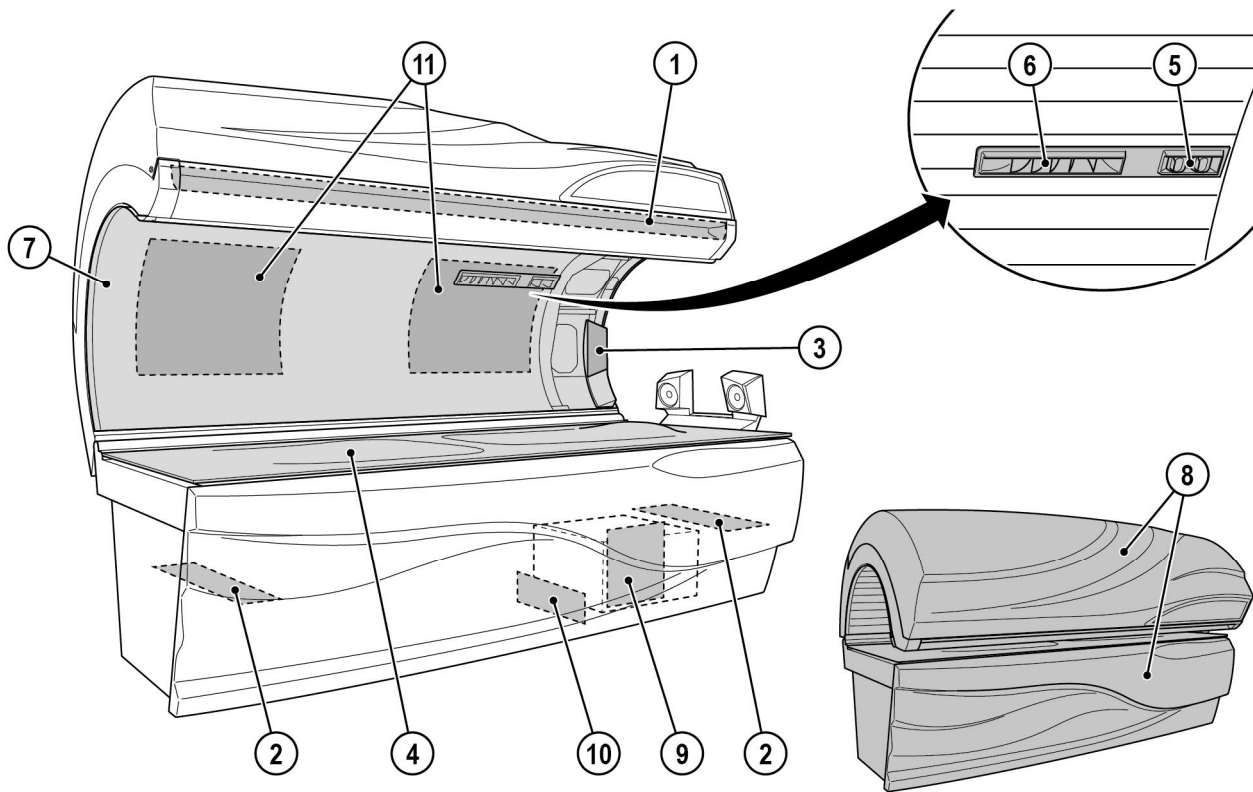

21217/0

| Component | | Interval | | Activity | See page | |
|-----------|------------------------|----------------------------|----------------|---------------------|-----------------------------|----|
| | | After each tanning session | When necessary | | | |
| 1 | Handle | X | | Clean and disinfect | 41 | |
| 2 | Filter | | | X | Remove and clean filter | 59 |
| 3 | EASY CONTROL | X | | Clean and disinfect | 41 | |
| 4 | Acrylic glass panel | X | | Clean and disinfect | 42 | |
| 5 | Adjustable air nozzles | X | | Clean and disinfect | 41 | |
| 6 | Air nozzles | | X | Clean | 41 | |
| | Protective goggles | X | | Clean and disinfect | 41 | |
| 7, 8 | Surfaces | | X | Clean | 42 | |
| 9 | Filter | | | X | Remove and clean filter | 59 |
| 10 | Filter | | | X | Remove and clean filter | 59 |
| 11 | Filter mat | | | X | Remove and clean filter mat | 62 |

**NOTE:**

When the cleaning mode is activated in SETUP MANAGER and the run-on time of the device fan has finished, cleaning must be confirmed after every tanning session by pressing the START/STOP button.



4.5 Maintenance

Maintenance and care play a major role in deciding whether the device meets the requirements placed on it in a satisfactory manner. Compliance with the specified maintenance intervals and the careful conducting of the maintenance and care work are therefore absolutely necessary.

The current operating hours of maintenance parts can be called up in service mode (see 'SETUP MANAGER'), order no. 1032680-..

We point out that the device must be subjected to regular inspections by our customer service or an approved specialized company every 12 months (from commissioning) to maintain its proper condition!

Inspections and maintenance work that has been carried out must be entered in the equipment, operating and maintenance booklet (order no. 1019967-..).

4.5.1 Acrylic glass

WARNING!



Cosmetics may cause cracks to form on the surface! Over the long-term cosmetics or sunscreens cause damage (e.g. crack formation on the surface).

- Ensure that cosmetics and sunscreens are removed before tanning.

The acrylic panels are made of acrylic glass that is specially developed for this field of application. The acrylics used are characterised by a particularly high UV permeability and resistance, as well as an easy-care, hygienic surface that is agreeable to the skin.

The acrylic glass panels are formed to device-specific shapes in a technically complex production process. Despite state-of-the-art production know-how, the presence of minor spots, air bubbles or streaks in the acrylic panels is unavoidable. In addition, hairline cracks can occur on the acrylic glass panel during operation.

These occurrences are material-related and are unavoidable in processing. However, they have no significant effect on use and are therefore not accepted as defects.

Over the course of time the acrylic glass panels becomes more translucent as a result of usage and must be replaced by customer-service personnel on a regular basis.



4.5.2 REMOTE SERVICE (optional)

Being the studio operator, you have the possibility to service your Ergoline Spirit Pure Light via REMOTE SERVICE. You can call up device information, e.g. operating hours and conduct a device configuration via REMOTE SERVICE. In case of service, the technical services can carry out a remote diagnosis online via REMOTE SERVICE.



NOTE:

More information on registration and use as well as a REMOTE SERVICE user manual (order no. 1019772-..) can be found on the homepage of Globalservice: www.jk-globalservice.de.

4.6 Maintenance plan

 **WARNING!**



Only use genuine spare parts of the same type! If other parts are used then the device no longer complies with the conformity declaration and may not be operated any longer!

Any liability for damage or injury proven to be the result of the use of non-genuine spare parts is excluded.

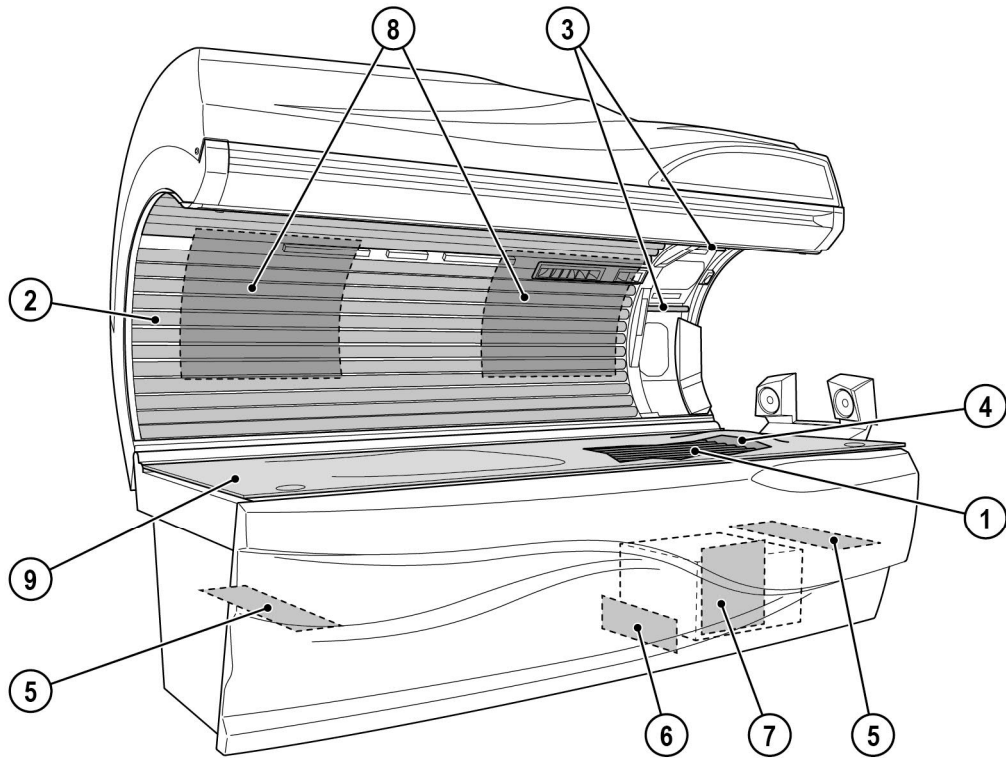

21218 / 0

| Component | Interval | | | | Activity | See page |
|-------------------------------------|---------------------|---------------------|----------------------|----------------------|----------|----------|
| | 500 operating hours | 800 operating hours | 1500 operating hours | 3000 operating hours | | |
| 1 Low-pressure lamps, base | | X | | | Replace | 57 |
| 2 Low-pressure lamps, canopy | | X | | | Replace | 58 |
| 3 Low-pressure lamps, facial tanner | X | | | | Replace | 58 |
| 4 Partition | | | | X | Replace | 49 |
| 5 Filter | | | | X | Replace | 59 |
| 6 Filter | | | | X | Replace | 59 |
| 7 Filter | | | | X | Replace | 59 |
| 8 Filter mats | | | X | | Replace | 62 |
| 9 Acrylic glass panel | | | X | | Replace | 49 |



Maintenance performed by authorized, trained and qualified staff

 **WARNING!**



Danger to people from maintenance work that has not been carried out!

If maintenance work is not carried out, it can lead to material damage or personal injuries!

- Maintenance work may only be carried out by trained and skilled personnel who have been authorised, instructed and qualified by JK-International GmbH, JK-Global Service department!
- The operator is responsible for compliance with the maintenance intervals!

The maintenance work must be carried out in accordance with checklist 1019858-.. by a JK Factory Certified Technician at the manufacturer or by personnel who have been authorized, trained and qualified by the manufacturer.

The correctly carried out maintenance work must be entered and confirmed in checklist 1019858-..

The maintenance work must be carried out at the following intervals:

- Every 1500 hours
- Annually or every 2000 hours, whichever is sooner.
- Every 3000 hours
- Every 5000 hours
- After 10 years or 20,000 hours, whichever is sooner.

Once the age of the unit reaches ten (10) years from the date of manufacture, its condition must be assessed by a JK-International GmbH, Division JK-Global Service Certified Technician before use of the unit can be continued.

Failure to have this unit assessment performed may result in personal injury or property damage.

Any liability is excluded if use of the unit continues ten (10) years after the date of manufacture, without the "condition assessment" having been performed.

4.7 Cleaning and maintenance work preparation



4.7.1 Service kit

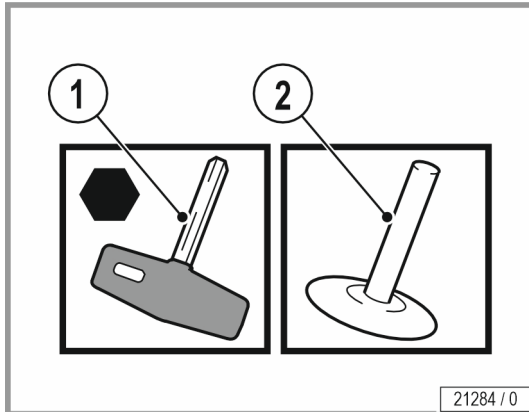

1. Allen key
2. Suction cup for partition

4.7.2 Lift up the acrylic glass panel and remove the partition

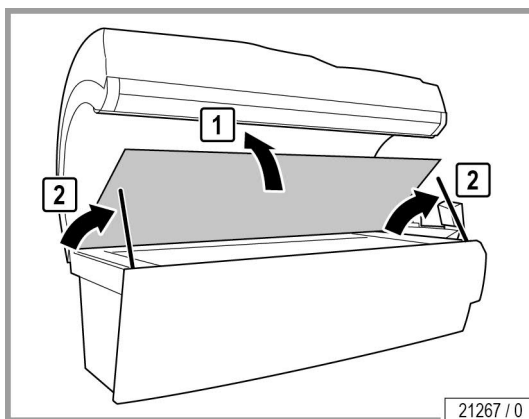

- Lift up the acrylic glass panel.
- Set up the brackets and prop the acrylic glass panel on the brackets.

WARNING!



Risk of scratching!
Use the recesses provided on the acrylic glass panel.

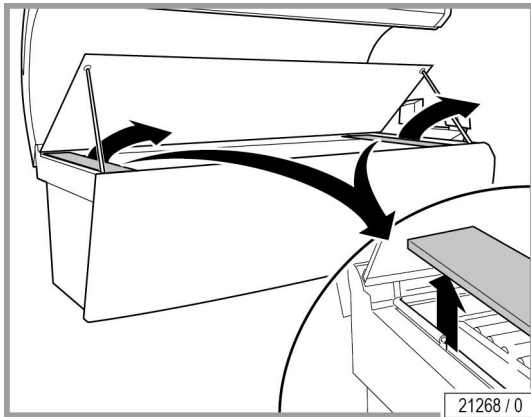

- Remove the lamp covers at the head and foot ends.

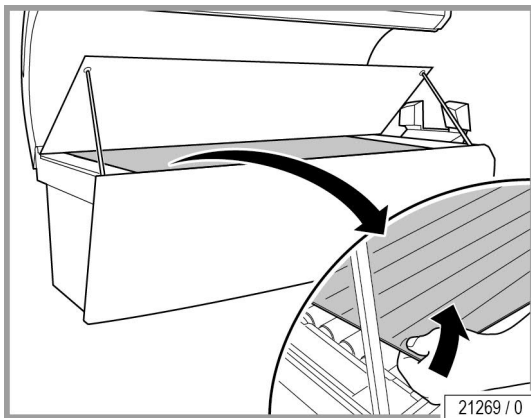

- Lift up the partition with the suction cup.

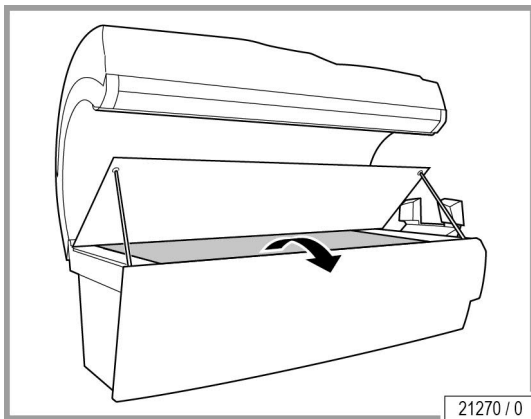

- Remove the partition.

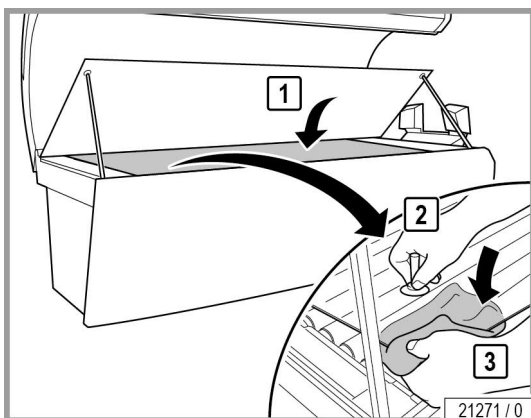

The assembly is the same process in reverse order.
When assembling please note:

- Clean the partition.
- To protect against fingerprints, hold the partition with a cloth.

4.7.3

Remove the canopy panel

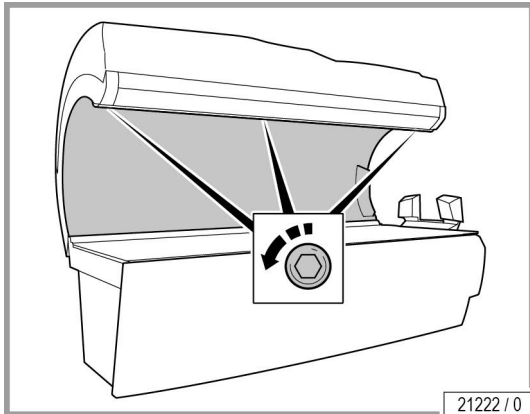

- Undo the screws.
- Support the canopy panel with one hand so that it doesn't fall down.

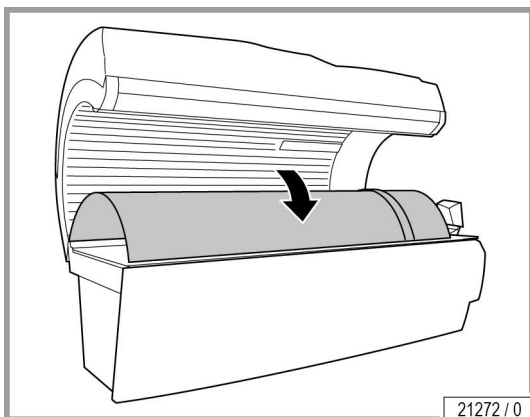

- Place the canopy panel carefully to one side.

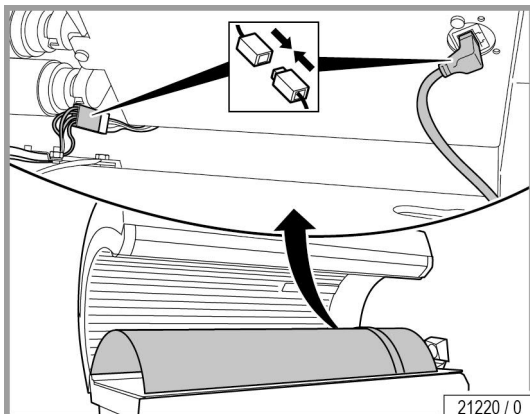

To replace the low-pressure lamps, the canopy panel must be completely removed from the device.

- Pull out the plug.

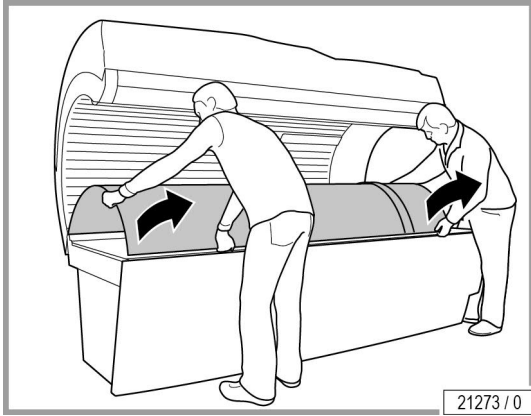

- Have another person help you to remove the canopy panel.

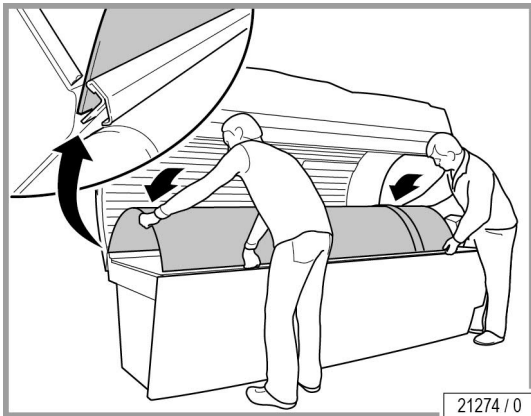

When assembling please note:

- Carefully insert the canopy panel into the guide.

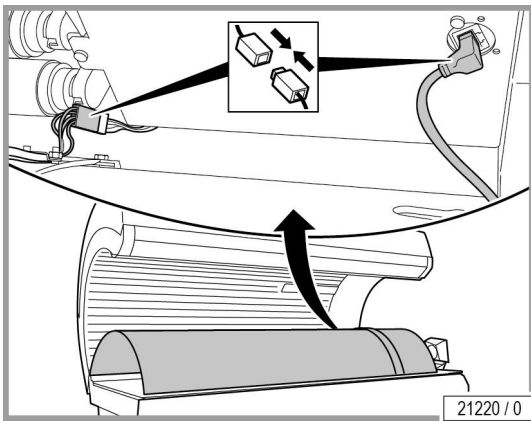

- Plug in the plug.

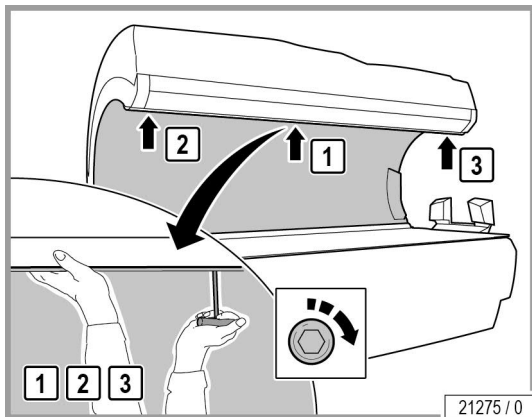

- Support the canopy panel with one hand so that it doesn't fall down.
- Tighten the screws: the middle ones first, then the outer ones.
- Carefully remove fingerprints and other soiling.



4.7.4

Removing the front panel

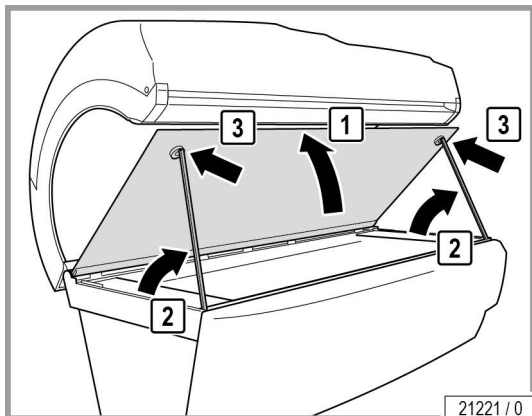

- Lift up the acrylic glass panel and support on the props.

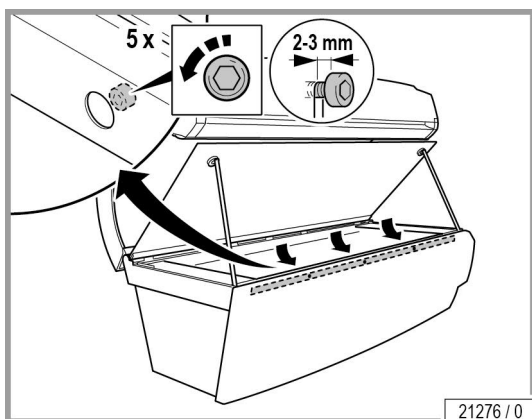

- Loosen the 5 screws (do not remove):
First loosen the middle screw, then loosen the right- and left-hand screws.

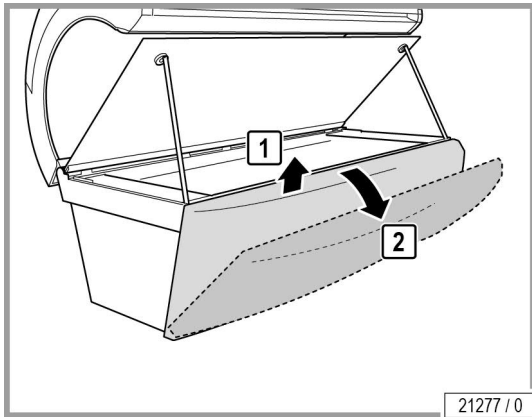

- First lift the front panel (1) up slightly.
- Tilt the front panel to the service position (2).

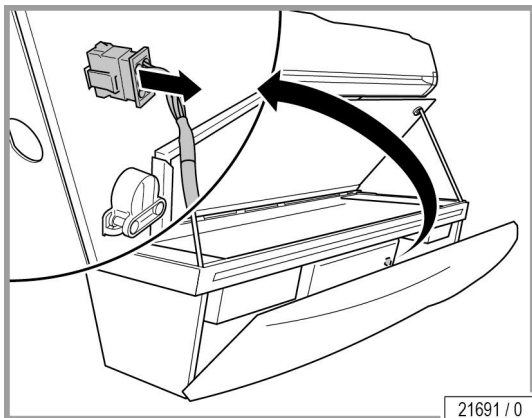

- Unplug the plug ST 54 from the parts carrier.

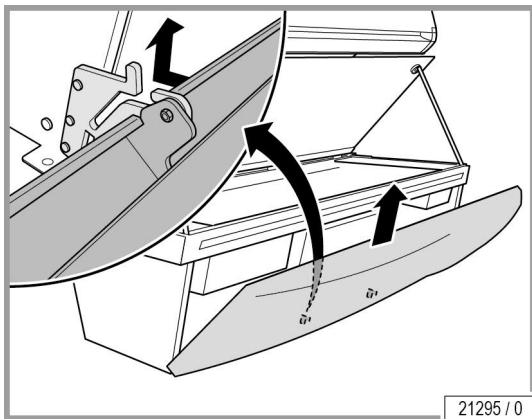

- Remove the front panel from the guide.

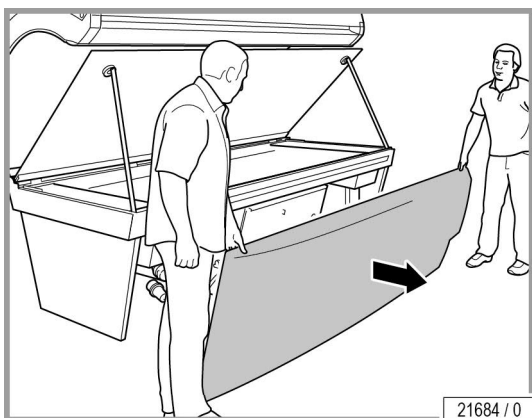

- Working in a pair (2 people), carry out the front panel and place it to one side.

4.8 Instructions for replacing the lamps



DANGER!



Danger of burns from hot lamps and surfaces!
Finger and hands may get burned when replacing lamps.

- Before carrying out maintenance work, wait until the device has cooled down sufficiently.



NOTICE:

Small quantities of mercury can escape if the bulb/lamp glass breaks! Please comply with the following instructions:

- Immediately disconnect the device from the mains power.
- Children must leave the room immediately.
- Ventilate the room for at least 15 minutes.
- Put on disposable gloves.
- With the window open: Collect the glass shards and escaped mercury in a sealable container.
- Bring the container to a collection site for waste lamps.



4.8.1 Low-pressure lamps

 **DANGER!**



Danger of burns from hot lamps and surfaces!
Finger and hands may get burned when replacing lamps.

- Before carrying out maintenance work, wait until the device has cooled down sufficiently.

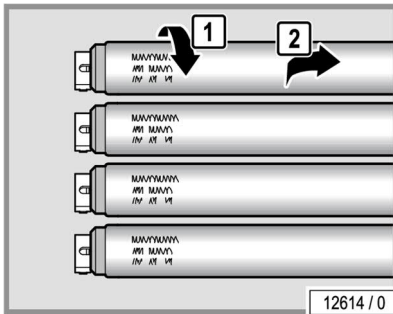

- Replace faulty low-pressure lamps immediately.
- Always replace the entire set of lamps after the specified operating time.
- Turn 90° and carefully remove from the socket.

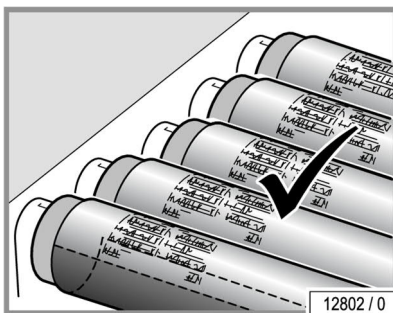

- Low-pressure lamps possess a reflector which directs the light outwards. The lamps must be mounted in such a way that the rear side of the reflector is located on the inside of the unit.

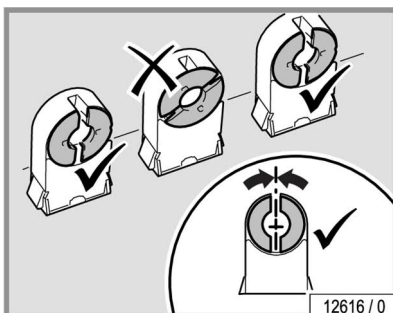

- Push the pins vertically into the socket from above.

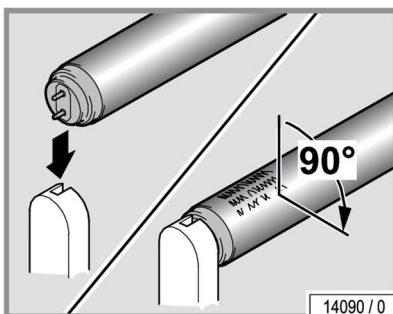

- Turn the lamp 90°. The lettering must be oriented towards the outside (i.e. towards the tanning room or towards the user).

4.9

Cleaning or replacing lamps in the base

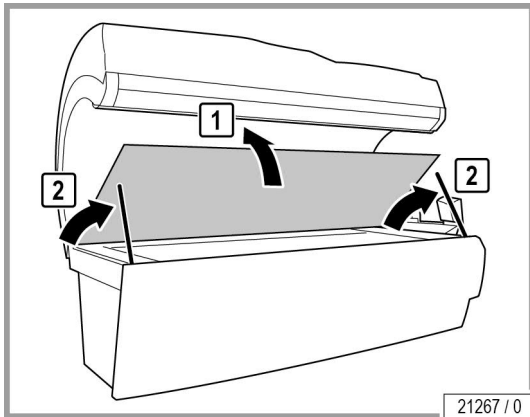

- Lift up the acrylic glass panel.
- Set up the brackets and prop the acrylic glass panel on the brackets.

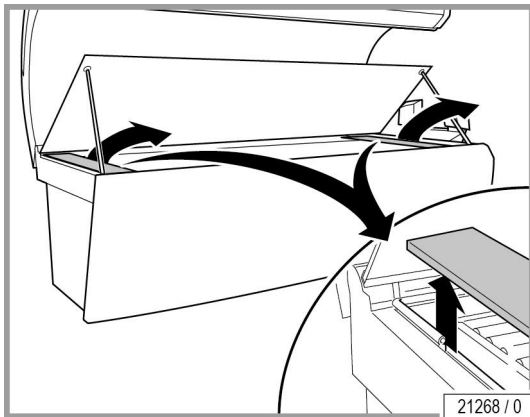

- Remove the lamp covers at the head and foot ends.

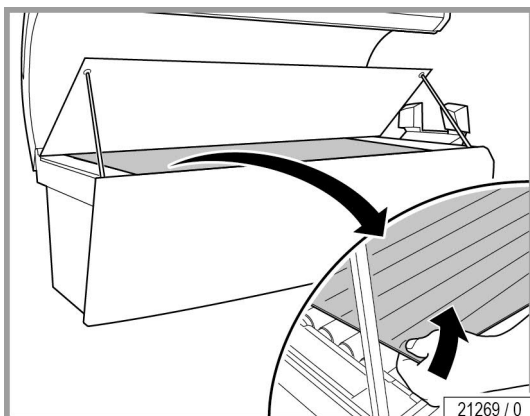

- Lift up the partition with the suction cup.

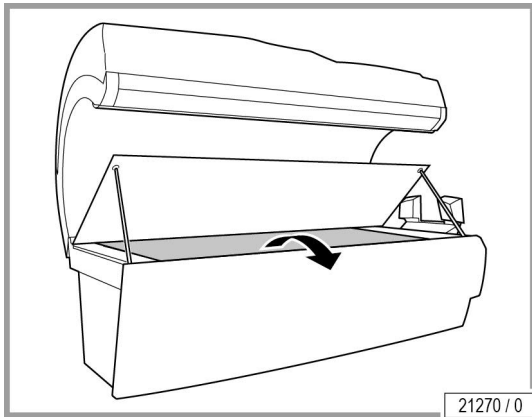

- Remove the partition.

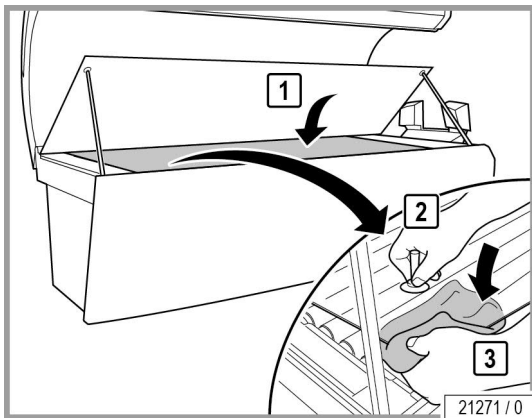

The assembly is the same process in reverse order.
When assembling please note:

- Clean the partition.
- To protect against fingerprints, hold the partition with a cloth.

4.10

Cleaning or replacing lamps in the canopy

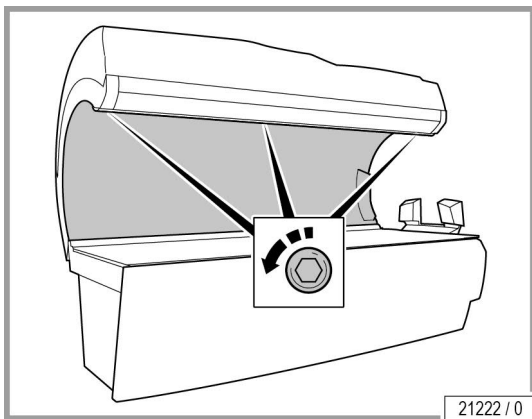

- Removing the canopy panel: see page 51.

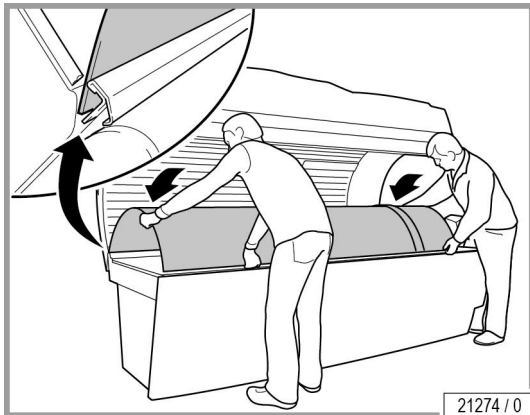

21274 / 0

When assembling please note:

- Carefully insert the canopy panel into the guide.



The assembly is the same process in reverse order.

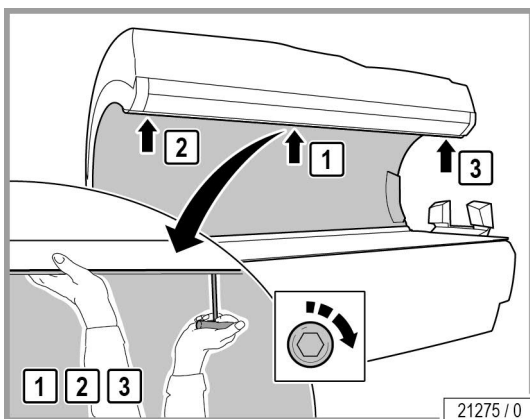

21275 / 0

- Support the canopy panel with one hand so that it doesn't fall down.
- Tighten the screws: the middle ones first, then the outer ones.
- Carefully remove fingerprints and other soiling.

4.11

Cleaning the filters in the base

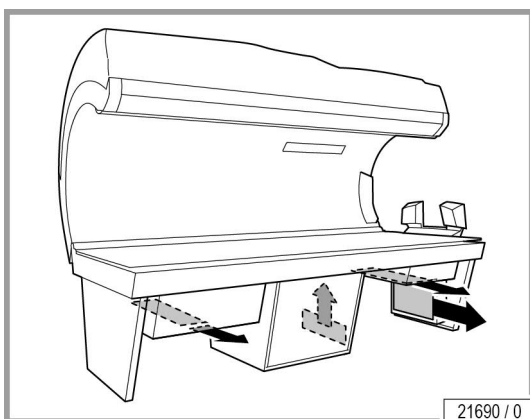

21690 / 0

- Removing the front panel: see page 53.
- Pull the outer filter out to the front. Pull the middle filter out to the top.

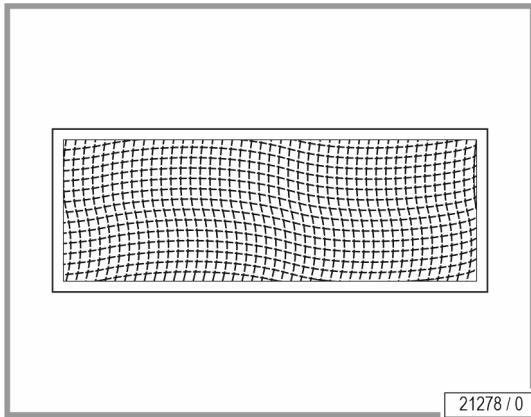

- Clean the filter dry or wet.

Dry cleaning: Vacuum cleaner (depending on the degree of soiling)

Moist cleaning: Use water and detergent or put in a dishwasher

 **WARNING!**



The device may be damaged by moisture!
The cleaned filters must be dry before they are replaced.

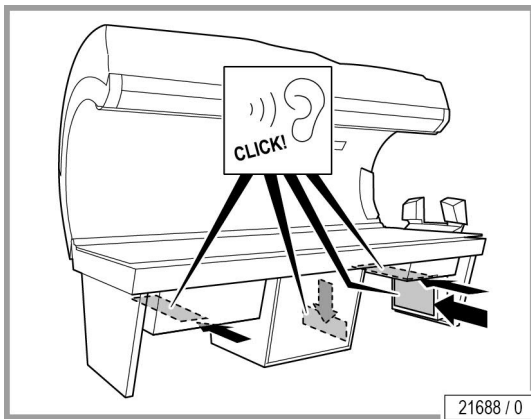

- Refit the cleaned and dried filter mats. The outer filter mats audibly engage.

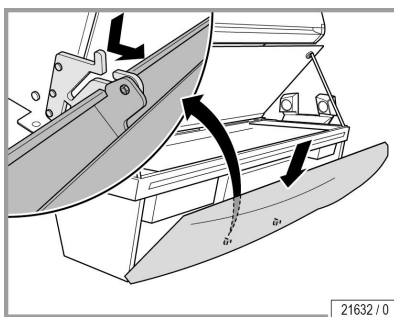

- Lift up the acrylic glass panel.
- Insert the front panel into the guide.
- Tilt the front panel into the service position.

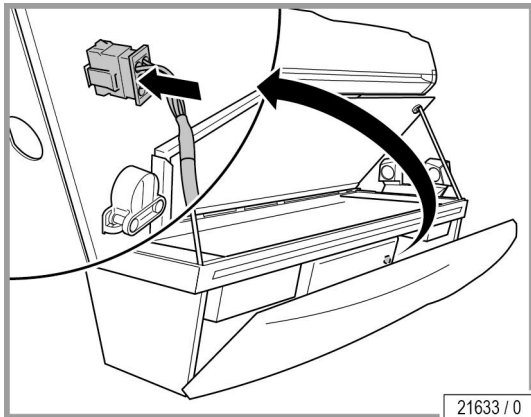

- Plug the plug ST 54 into the parts carrier.

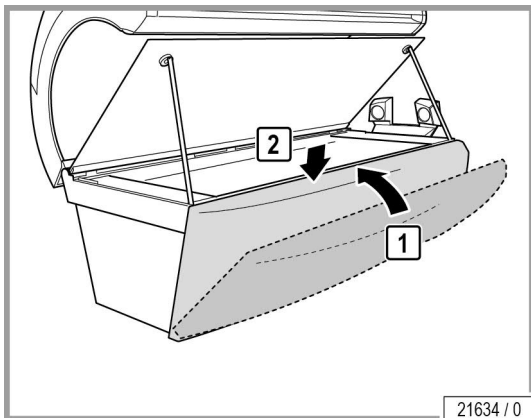

- Close the front panel (1).
- Press the front panel down slightly (2).

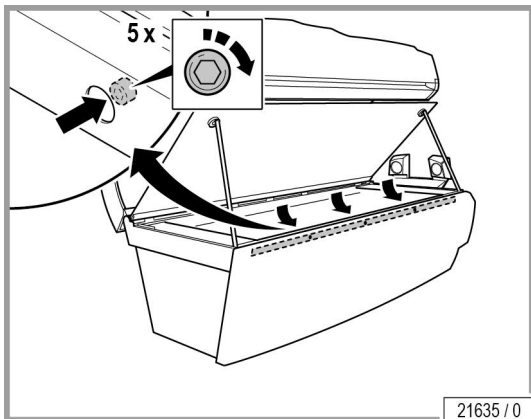

- Tighten the 5 screws:
First tighten the middle screw, then the right- and left-hand screws.



4.12 Cleaning the canopy filter mats

 **DANGER!**



Fire hazard due to dust particles in the air intake openings!

Dust particles are flammable! Regularly remove dust particles from the air intake area.

- Use a vacuum cleaner to prevent dust particles from getting inside the unit.

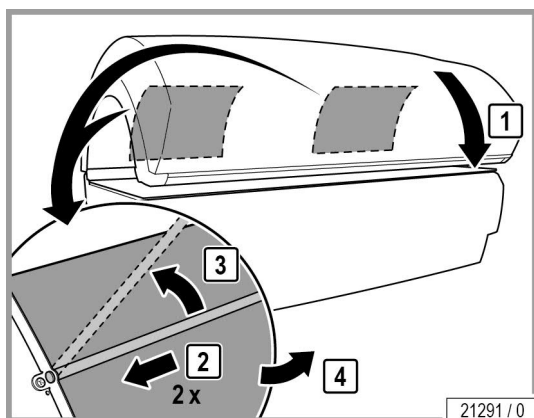

- Cover the canopy if necessary to prevent the paintwork from being scratched.
- Remove the filter mat on the back of the canopy.

 **CAUTION!**



The unit may be damaged by moisture!

The cleaned filter mats must be dry before they are replaced.

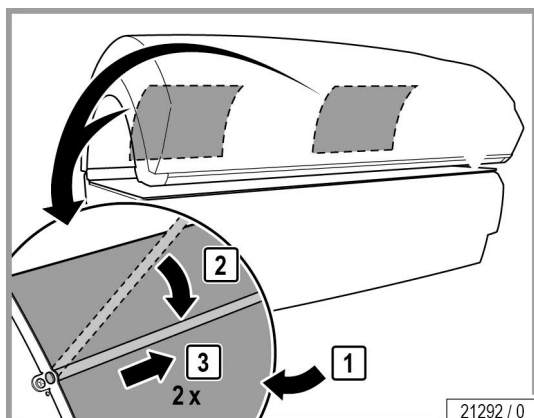

- Refit the cleaned and dried filter mats.

5 Technical data



5.1 Power, connection rating and noise level

Ergoline Spirit Pure Light

| | |
|--|--|
| Power consumption rating without air conditioning: | 6300 W |
| Rated frequency: | 50 Hz |
| Rated voltage: | 400-415 V 3N~ |
| Rated fuses: | 3 x 16 A (inactive) |
| Connecting line: | H05VV-F 5G 2,5 mm ² (scope of delivery) |
| Noise level 1m away from device: | 62,9 dB(A) |
| Noise level inside the device: | <70 dB(A) |
| Load on the acrylic glass panel: | max. 135 kg |
| Weight: | 392 kg |

5.2 Dimensions

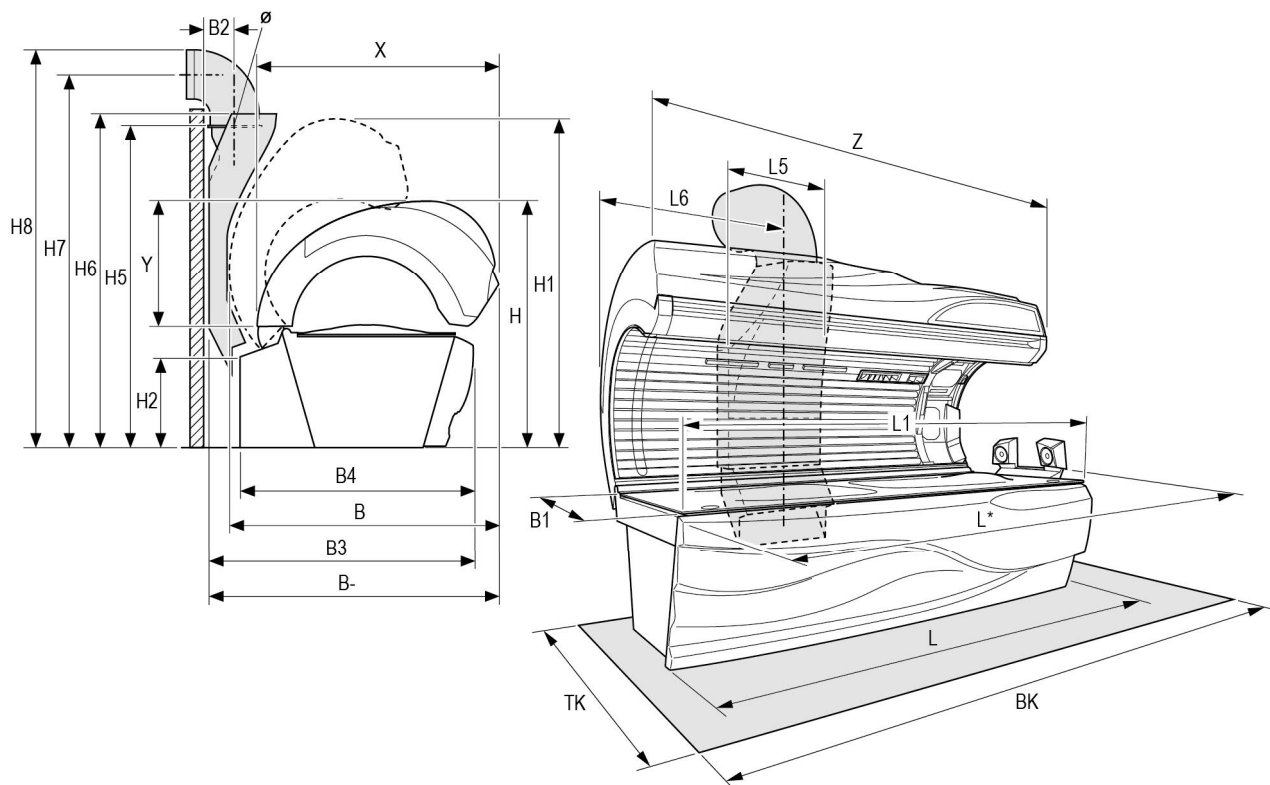

21209 / 0

| | | | |
|-------|------------------------|------|---------|
| B = | 1370 mm | X = | 1264 mm |
| B - = | 1505 mm | Y = | 689 mm |
| B1 = | 835 mm | Z = | 2160 mm |
| B3 = | 1450 mm | Ø = | 300 mm |
| B4 = | 1270 mm | BK = | 2400 mm |
| L = | 160 mm | TK = | 2100 mm |
| | (without sound system) | | |
| L* = | 2260 mm | | |
| | (with sound system) | | |
| L1 = | 2150 mm | | |
| L5 = | 650 mm | | |
| L6 = | 1080 mm | | |
| H = | 1260 mm | | |
| H1 = | 1705 mm | | |
| H2 = | 460 mm | | |
| H5 = | 1710 mm | | |
| H6 = | 1765 mm | | |
| H7 = | 2020 mm | | |
| H8 = | 2170 mm | | |

5.3 Lamp sets



! WARNING!



The conformity declaration applies for the specified lamps. The use of other lamps voids the operating licence.

Moreover, the lamps must be marked with a matching equivalence key, see attachment page 67.

5.3.1 Ergoline Spirit Pure Light

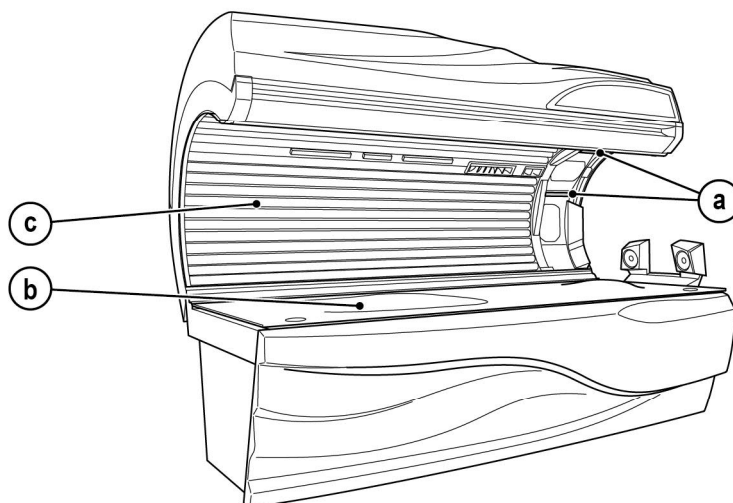

21320 / 0

Lamp set (UV type 2)

| | Number | Description | Length | Power | Control | Order-no. |
|----|--------|---|--------|-------|-----------|------------|
| a) | 2 | UV low-pressure lamps ERGOLINE TREND 8 W E27 | 0.31 m | 8 W | 8 W / 0 W | 1517170-.. |
| b) | 18 | UV low-pressure lamps ERGOLINE TREND ADVANCED 100 W R E6 | 1.80 m | 100 W | 120 W | 1509050-.. |
| c) | 24 | UV low-pressure lamps ERGOLINE TREND DIRECT R31 160 W CS | 1.80 m | 160 W | 160 W | 1023987-.. |

5.4 Spare parts and accessories

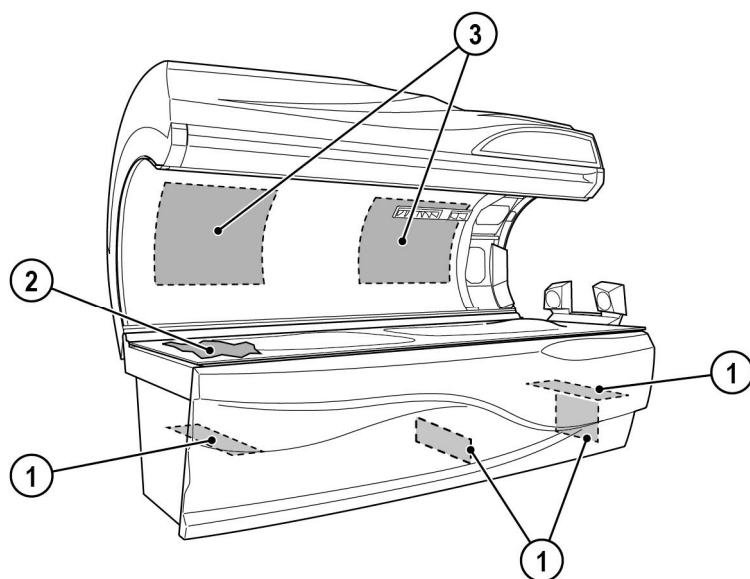

21310 / 0

| Number | Description | Order-no. |
|--------|---------------|------------|
| 1 | 4 Filter | 55567-.. |
| 2 | 1 partition | 1516684-.. |
| 3 | 2 Filter mats | 1013452-.. |

6 Appendix



6.1 JK timer controls

The following time control system can be utilised with the Ergoline Spirit Pure Light series units:

HK MICROTIMER 8250 order no.: 500001653

6.2 Equivalence key range

Example for calculating the equivalence key range (1), see the lamp configuration sticker:

If the equivalence key of the lamp with which the device has been equipped during the type approval is

100-R-47/2,7

the equivalence key range with which the device should be marked is calculated as follows:

Bottom value of the X section: $0,75 \times 47 = 35,25$

Bottom value of the Y section: $0,75 \times 2,7 = 2,03$

Top value of the Y section: $1,25 \times 2,7 = 3,38$

X is rounded up to the next whole value, Y will be rounded to the first decimal place after the point.

The equivalence key range for fluorescent lamps is then:

100-R-(35-47)/(2,0-3,4)

| | | Ergoline Spirit 170-S DYNAMIC POWER | | |
|----------------------------|-----|-------------------------------------|----------------------------|---|
| ① | 18x | | Ergoline TREND 80-200 W ES | 1604288- 100-R- (35-47)/(2,0-3,4) |
| ② | 8x | | Ergoline TREND 80-200 W ES | 1604288- 100-R- (35-47)/(2,0-3,4) |
| ③ | 20x | | Ergoline TREND 80-200 W ES | 1604288- 100-R- (35-47)/(2,0-3,4) |
| ④ | | 4x | Ergoline ULTRA 82W | 1604288- |
| | | 2x | ULTRA PERFORMANCE 80 | 1604288- |
| | 3x | 2x | ULTRA PERFORMANCE 80 | 1604288- |
| | | | Ergoline TREND 8 W ES | 1604288- |
| ⑤ | - | - | Ergoline TREND 80-200 W ES | - 100-R- (35-47)/(2,0-3,4) |
| ⑥ | | 2x | Ergoline ULTRA 100 W | 1604288- |
| | | 2x | ULTRA PERFORMANCE 80 | 1604288- |
| | | 2x | ULTRA PERFORMANCE 80 | 1604288- |
| JK-Products GmbH / GERMANY | | | 1000000-01 | |

13192 / 1



6.2.1 Description of the equivalence keys for fluorescent lamps

The equivalence key for fluorescent lamps for tanning that is represented in detail in the IEC 61228 and that is marked on the lamp in a readable and permanent manner, is described in the following.

The equivalence key has the following structure:

Wattage – Reflector type key – UV key.

The following reflector type key should be used for the equivalence key:

O with lamps without reflector;

B with lamps that have a wide reflecting angle $\alpha > 230^\circ$;

N with lamps that have a narrow reflecting angle $\alpha < 200^\circ$;

R with lamps that have the usual reflecting angle $200^\circ \leq \alpha \leq 230^\circ$.

The following UV key should be used for the equivalence key:

UV key = X/Y;

X = the entire effective erythemal UV radiation strength across the range 250 nm to 400 nm;

Y = the relationship of the non-melanoma skin cancer effective UV radiation strength ≤ 320 nm and > 320 nm.

X is specified in mW/m^2 and rounded up to the next whole value, Y will be rounded to the first decimal place after the point. The effective values apply for a distance of 25 cm and under the conditions of an optimum UV radiation strength.

Note

One example for an equivalence key is specified below:

- 100 W reflector lamp with a reflector angle of 220°
- erythemal UV radiation strength (250 nm to 400 nm) = $47 \text{ mW}/\text{m}^2$
- short wave NMSC effective UV radiation strength (≤ 320 nm) = $61 \text{ mW}/\text{m}^2$
- long wave NMSC effective UV radiation strength (> 320 nm) = $19 \text{ mW}/\text{m}^2$
- lamp equivalence key: 100–R–47/2,7

7 Index



A

| | |
|---|--------|
| Accessories..... | 28, 66 |
| Acrylic glass (care)..... | 42 |
| Acrylic glass panel - sunbed..... | 45 |
| Acrylic glass panel, permitted load..... | 63 |
| Acrylic glass panels (product information)..... | 45 |
| Adolescents | 7, 29 |
| Allergies..... | 29 |
| Assembly..... | 13 |
| Audio files | 19 |

B

| | |
|------------------|----|
| Bluetooth® | 37 |
|------------------|----|

C

| | |
|---------------------------------|--------|
| Care | 41 |
| Children | 9 |
| Cleaning..... | 40, 41 |
| Filter mats..... | 62 |
| Lamps | 42 |
| Cleaning intervals | 44 |
| Cleaning or replacing lamps | |
| Canopy | 58 |
| Cleaning or replacing the lamps | |
| Base..... | 57 |
| Cleaning overview..... | 44 |
| Cleaning the filter..... | 59, 62 |
| Cleaning, filter | 59 |
| Commissioning..... | 16 |
| Contact lenses | 29 |
| Cosmetics | 9 |
| Customer service..... | 2 |

D

| | |
|----------------------------|----|
| Damage | 25 |
| Decommissioning..... | 17 |
| Definitions | 5 |
| Description | 27 |
| Device operating time..... | 16 |
| Dimensions | 64 |
| Directives..... | 18 |
| Disposal..... | 17 |



| | |
|---------------------------------------|--------|
| E | |
| Electrical installation | 14 |
| Electrical specifications | 63 |
| Equipment | 26 |
| Equivalence key range | 67 |
| Error codes | 41 |
| Exhaust air ventilation | 14 |
| Export | 18 |
| Eye damage | 29 |
| F | |
| Faults | 41 |
| Filter | |
| Cleaning intervals | 44 |
| Foreseeable misuse | 7 |
| Functions | 33 |
| I | |
| Illnesses | 29 |
| Intended use | 7 |
| Itching | 29 |
| L | |
| Lamp sets | 65 |
| Lamps | 7 |
| Control | 65 |
| Power levels | 65 |
| Rated power | 65 |
| Liability | 25 |
| Lift up the acrylic glass panel | 49 |
| Light sensitivity | 29 |
| M | |
| Maintenance | 40, 45 |
| Maintenance intervals | 46 |
| Maintenance overview | 46 |
| Make-up | 29 |
| Medicaments | 29 |
| Music | 19, 39 |
| N | |
| Network | 46 |
| Noise level | 63 |

O

| | |
|---------------------------------|--------|
| Operating altitude | 15 |
| Operating overview | 31 |
| Operator's obligations | 13 |
| Optical components (care) | 43 |
| Order numbers | 65, 66 |



P

| | |
|--|----|
| Packaging..... | 18 |
| Performance rights..... | 19 |
| Personnel training..... | 13 |
| Plastic surfaces (care) | 42 |
| Plug-in connector..... | 14 |
| Power..... | 63 |
| Preclusion of damage | 25 |
| Prohibited usage..... | 8 |
| Protective glasses | 9 |
| Protective measures when performing maintenance work | 40 |

R

| | |
|-------------------------------------|----|
| Radiation area | 39 |
| Recycling | 17 |
| Remote SERVICE | 46 |
| Remove the canopy panel | 51 |
| Removing the front panel | 53 |
| Replace the low-pressure lamps..... | 56 |
| Replacing the lamps | 55 |
| Restrictions | 9 |
| Risk of injury..... | 29 |

**S**

| | |
|---|--------|
| Safety | 14 |
| Safety instructions | |
| Device-specific safety instructions | 8 |
| General safety instructions..... | 13 |
| Scope of delivery | 13, 26 |
| Service kit..... | 49 |
| Setup | 13 |
| Setup location..... | 15 |
| SETUP MANAGER..... | 32 |
| Showering | 29 |
| Size..... | 64 |
| Skin sensitivity..... | 11 |
| Skin type..... | 11 |
| Spare parts..... | 46 |
| Order numbers..... | 66 |
| SPECTRA LED Boards (care) | 43 |
| Starter..... | 65 |
| Starting the tanning..... | 37 |
| Start-up adjustments..... | 37 |
| Storage..... | 17 |
| Sunburn..... | 29 |
| Symbols | 6 |

T

| | |
|----------------------|----|
| Tanning times..... | 12 |
| Technical data | 63 |
| Time control..... | 16 |
| Transport..... | 13 |

U

| | |
|-----------------------|----|
| Unit description..... | 27 |
| UV exposure..... | 9 |

V

| | |
|------------------|----|
| Ventilation..... | 14 |
| Volume | 39 |