

USA



Operating instructions

REVIVE PRO IR Laydown
Model-No.: JK 199 / RV 0-46

1030889-00C / us-en / 02.2024



Contact information



Customer Service JK Products & Services
 411 West Washington Avenue
 Suite B
 Jonesboro, Arkansas 72401
 800-445-0624
 870-935-9046
<http://jkproducts.us/service>

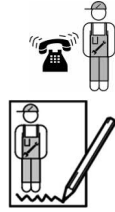

Manufacturer JK-Products GmbH
 Rottbitzer Str. 69
 53604 Bad Honnef
 GERMANY
 Tel.: +49 (0) 22 24 / 818-140
 Fax: +49 (0) 22 24 / 818-166



WARNING!



Read these operating instructions.

Failure to observe these instructions:

- may result in serious injury and death,
- can result in damage to the device and the environment.
- For the safety of yourself and others, read and observe all instructions contained herein before operating the device.
- Please make the instructions and additional information available to anyone who operates or services the device.

Copyright

The copyright remains with JK-Holding GmbH.

The contents may not be duplicated (in whole or part), distributed or utilized for competition purposes without authorization or disclosed to other parties.

The right to make technical changes in regard to the figures and information contained in this instruction manual is reserved!

1 Table of Contents



2	What certain words and signs mean (Glossary).....	6
2.1	Definitions	6
2.2	Warning signs	7
2.3	Symbols on the device	8
3	What this device is	9
3.1	Guidelines.....	9
3.2	Export	9
3.3	Scope of delivery	9
3.3.1	Options	9
3.4	Device description	10
3.5	Options	10
3.6	Function description.....	10
3.7	Transport.....	11
3.8	Installation location.....	11
3.8.1	Ventilation	11
3.8.2	Setup location.....	12
3.8.3	Commissioning.....	14
3.9	Signs and stickers on the device	15
3.10	Technical data	17
3.10.1	Power rating, electrical specifications and noise level	17
3.10.2	Dimensions	18
3.10.3	Lamp configuration	18
3.10.4	Accent lighting	18
3.10.5	Spare parts.....	19
4	Why you use it	20
4.1	Intended use	20
4.2	Skin condition	20
5	Who cannot use it	21
5.1	Prohibited usage.....	21
5.1.1	REVIVE system	21
5.1.2	Vibra Shape (vibration plate)	21
6	What you must do to avoid serious harm	22
6.1	General	22
6.2	REVIVE system	23
6.3	Sensor	23



7	What you must do to avoid other harm.....	24
7.1	General	24
7.2	REVIVE system	24
7.3	Sensor	24
7.4	Vibra Shape - vibration plate	24
7.5	Foreseeable misuse	25
7.6	Obligations of the studio operator.....	25
7.7	Staff training	25
8	Risks of using this device	26
9	Benefits of using this device.....	27
10	How to decide to use this device.....	28
11	What to do before the application	29
12	How to use this device	30
12.1	How to set this device up.....	30
12.2	How to make sure the device works	30
12.3	How to use it to treat your condition	30
12.4	How to choose correct application regimen.....	30
12.4.1	Application times.....	30
12.5	How to operate the device	31
12.5.1	Control Center	31
12.5.2	User settings overview	31
12.6	Functions.....	32
12.6.1	Navigation	33
12.6.2	Info / Maintenance / Button lock.....	34
12.6.3	Timer settings / External Timer setting.....	35
12.7	Operating display of the sensor.....	35
12.8	Selection of the application	35
12.9	Sun Select setting with the outer interface	35
12.10	Measurement (automatic mode).....	35
12.11	Connections	36
12.12	How to use	36
12.12.1	How to start	36
12.12.2	Application tips	37
12.12.3	How to stop.....	37
12.13	What to do after the application	38
12.13.1	Cleaning and disinfection.....	38
12.14	Safety instructions for cleaning/ disinfection and maintenance	39
12.15	How to clean/disinfect	41
12.15.1	Cleaning and disinfection of surfaces.....	42
12.15.2	Cleaning/disinfection plan	43
12.16	How to maintain.....	44
12.16.1	Technical modifications.....	44
12.16.2	Maintenance schedule for wear parts.....	44

12.16.3	Cleaning and maintenance work preparation.....	46
12.16.4	Instructions for replacing the lamps	46
12.16.5	Cleaning and disinfection of the sensor.....	47
12.16.6	Disassembly for maintenance and cleaning work.....	47
12.16.7	Removing the canopy panel.....	48
12.16.8	Removing the acrylic panel	49
12.16.9	Changing the AROMA card	51
12.16.10	Cleaning the ventilation slot.....	51
12.16.11	Cleaning or replacing lamps and filter panels in the canopy.....	51
12.16.12	Cleaning or replacing the lamps and filter panels in the shoulder tanner	51
12.16.13	Cleaning or replacing Ambient Light	51
12.16.14	Cleaning or replacing the canopy accent lighting.....	51
12.16.15	Cleaning or replacing the front panel accent lighting.....	52
12.16.16	Cleaning the filters.....	52
12.16.17	Cleaning the filter mats	52
12.16.18	Cleaning the filter mats in shoulder tanner	52
12.16.19	Air conditioning: Empty the condensation tank and clean the filter	52
12.16.20	AQUA / AROMA SYSTEM maintenance	52
12.17	How to store the device	53
12.17.1	Decommissioning.....	53
12.17.2	Storage.....	53
12.17.3	Disposal.....	53
13	What to do when things go wrong	54
13.1	Troubleshooting.....	55
14	Where you can find out more	56
15	How we studied this device.....	57
16	Appendix	58
17	JK-Products, Inc. – Limited Warranty	59
17.1	Limited Acrylic Warranty	60
17.2	Warranty Claims	61
17.2.1	Policy & Procedures.....	61
17.2.2	Labor Warranty Claim/Credit Procedures	62
17.2.3	Quality inspection and acceptance form	62
17.3	Limited Lifetime Warranty.....	63
18	Index.....	64



2 What certain words and signs mean (Glossary)



2.1 Definitions

Studio operator

People who provide devices to users on a commercial basis. The studio operator is trained to operate and maintain the device and is responsible for the orderly operation of the device as well as compliance with the maintenance intervals.

User

A person who uses the device at a commercial location.

Staff

People who are responsible for the operation, cleaning/disinfection as well as general maintenance work and who instruct the users in the operation of the devices.

JK Factory Certified Technician

Level 1

Authorized to perform general maintenance such as replacing lamps, aqua mist, and fragrance containers as well as overall cleaning of the unit.

Level 2

Authorized to perform maintenance and repairs such as replacement of ballast, framed acrylic, electronic circuit boards, and other electrical components.

Level 3

Authorized and trained to utilize JK Products proprietary diagnostic software to adjust operating parameters and perform detailed diagnostics.

Level 4

This individual is uniquely qualified to assess the condition of a unit and make a determination if the device meets the requirements for continued use ten (10) years from the date of manufacture.



NOTE:

Each technician level is authorized to perform the tasks of technician levels smaller in number to theirs. E.g. a level 3 technician is authorized to perform the tasks assigned to a level 1 and 2 technician.

2.2 Warning signs



Danger notices, nonobservance will lead to death or serious injury:

 **DANGER!**



Type and source of danger, e.g. 'DANGER – High voltage!'

Description of the consequences, e.g. 'You can be killed or injured by an electric shock!'

Countermeasures:

- Disconnect device from power supply before opening.
- Do not reach into the inside with the device switched on.

Warning notices, nonobservance can lead to death or serious injury.

 **WARNING!**



Type and source of danger, e.g. 'WARNING – hot surface!'

Description of the consequences, e.g. 'You can burn your hand (skin, face)!'

Countermeasures:

- Do not touch hot parts and nearby surfaces.
- Wait until hot parts and surfaces have cooled down.

NOTICE



ESD-sensitive components!

The word 'NOTICE' without warning sign points out that danger for devices, materials and the environment can be expected here.

Countermeasures:

- Avoid doing this.

Important information:



NOTE:

This symbol does not identify safety notices, but states information for a better understanding of the processes.



2.3 Symbols on the device

The following symbols are displayed on the device or on the packaging:



Manufacturer, company address



Read the operating instructions!

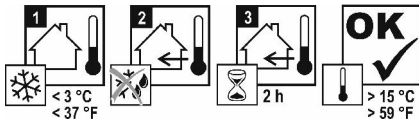

Where there are great differences in temperature between the transport route and the installation site the device may not be put into operation immediately after being set up.

Wait at least 2 hours before connecting the device to the power supply.



Maximum transport weight



Do not stack!



This side up.



Keep dry.



Temperature limitations.

The temperature limits are noted next to the upper and lower horizontal line.



Recyclable material.



Polystyrene



Cardboard



Mixed paper



Steel



Wood



Permitted air pressure during transport and storage.

3 What this device is



3.1 Guidelines

This product is in conformity with UL STD 482 and fulfils the requirements for the exempt group according to IEC 62471.

3.2 Export

This device is exclusively intended for use in the USA and may not be exported to other countries and operated there! The manufacturer assumes no liability whatsoever in the event of non-compliance. High liability risks may occur for the exporter and/or the studio operator in the event of noncompliance.

3.3 Scope of delivery

- REVIVE device
- AROMA card
- Protective goggles
- Allen-key
- Technical documentation

3.3.1 Options

Not applicable for this device.



3.4 Device description

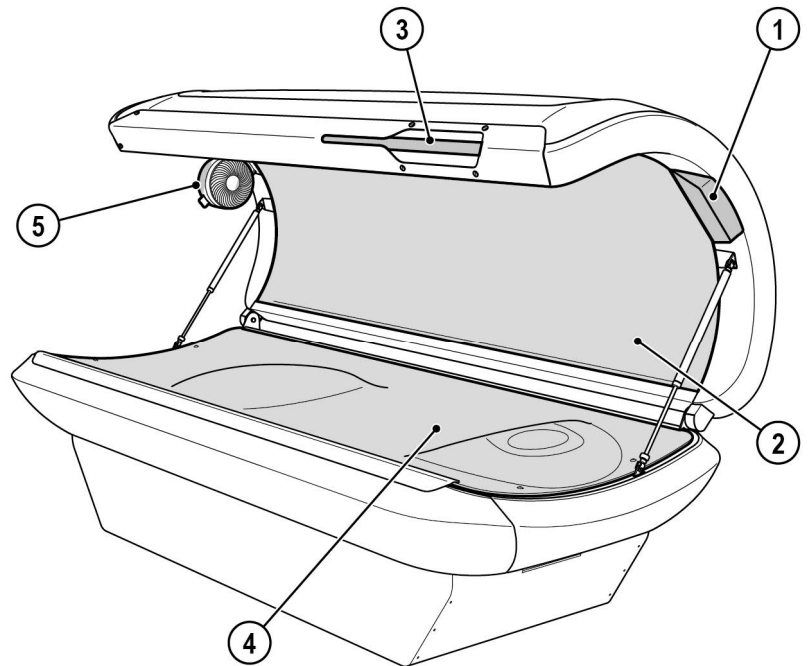

21159 / 0

1. INTERIOR DISPLAY
2. Red Light & Near Infrared LEDs, canopy
3. Handle, canopy
4. Red Light & Near Infrared LEDs, base
5. Body cooling with AROMA

3.5 Options

Not applicable for this device.

3.6 Function description

See page 31 for information on control and operation of the device and its features.

3.7 Transport

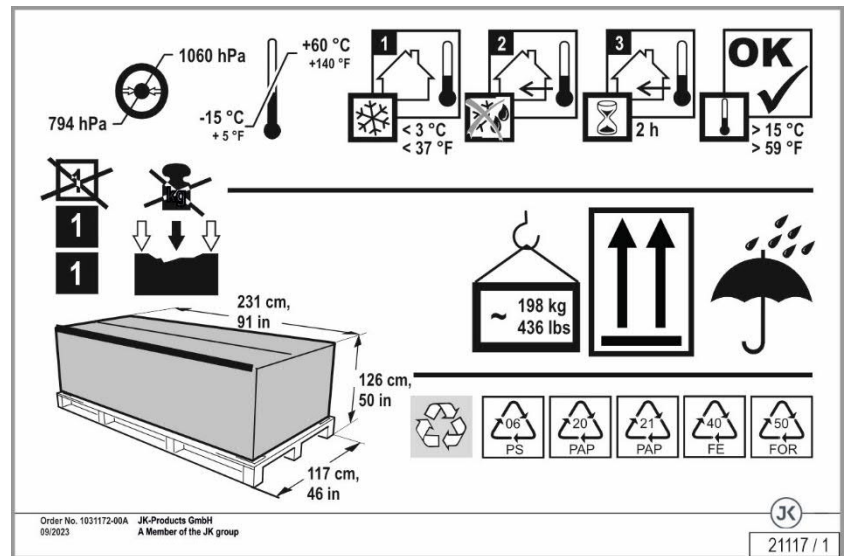

3.8 Installation location

This product is suitable for fitness studios or similar installation locations.

You may find detailed information on installation and setting up in the Installation Instructions (see folder Technical Documentation).

3.8.1 Ventilation

NOTICE

Danger of failure!

Danger of overheating by obstruction of the air routing.

- Observe the ventilation information to avoid serious system malfunctions.



3.8.2 Setup location

WARNING!



WARNING!

Sudden movements and malfunctions!
Crushing hazard.

- The device is not suitable for operation in mobile facilities (ships, buses, trains).

Risk of falling! Risk of being injured by falling objects!

Ceilings and joists may break if the load per square foot is too high!

- Ensure that ceiling and joists are sufficient for the weight of your device (see Installation Instructions in the folder Technical Documentation).

CAUTION!



Danger of overheating by obstruction of the air routing!

Any liability is excluded in case of damage or injury proven to be the result of the use of non-genuine spare parts.

- Do not change, obstruct or block the air inflow and outflow area to the device or make any unauthorized changes to the device. The manufacturer shall bear no liability for damage or injuries resulting from such actions.
 - Observe the ventilation information to avoid serious system malfunctions.
 - Before putting a device into operation, the transport pallet must be removed from under the device. Danger of overheating by obstruction of the air routing.
 - Maintain the minimum distances from the walls! Dimensions are given on page 18.
 - Only use OEM spare parts of the same type! The use of other parts will void the manufacturer's warranty!
-

NOTICE

Salty air! Contaminated air!

Device damage due to corrosion of the housing and electrical components.

- Do not install the device near swimming pools.
- Do not operate the device in locations with aggressive environmental conditions (e.g. air containing chlorine).

Damage to the device possible!

Where there are great differences in temperature between the transport route and the installation site the device may not be put into operation immediately after being set up.

- Wait at least 2 hours before connecting the device to the power supply.

Damage to the device possible!

The device is not to be used outdoors.

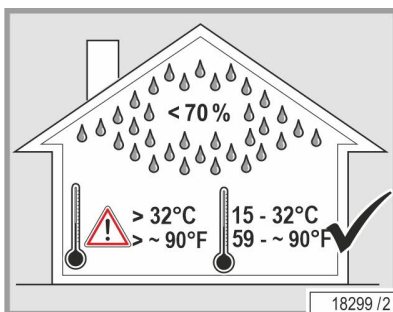
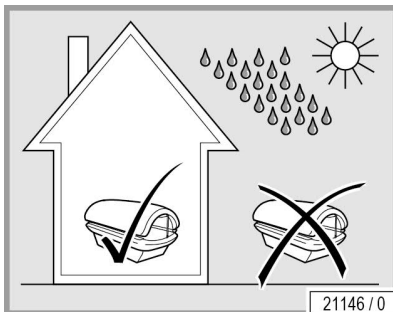

Environmental conditions

- Optimum ambient temperature: between 59 °F (15 °C) and ~90°F (32°C)
- Storage temperature: between 5 °F (-15 °C) and 140 °F (+60 °C)
- Air pressure: between 794 hPa and 1060 hPa
- Relative humidity: between 30 % and 70 %

Please contact the customer service department before putting the device into operation - see page 2.

You can obtain data regarding the air supply and ventilation from the customer service department (see page 2).



3.8.3 Commissioning

 **DANGER!**



Damaged mains power cable!

Danger to persons through electric shock or burns.

- Only the manufacturer or specialist companies are permitted to replace the mains power cable.

Initial commissioning will be undertaken by the manufacturer's own service personnel or by a (Level 3) JK Factory Certified Technician. The device will be handed over ready for use.

As the studio operator you are responsible for abiding by the electrical regulations applicable at the installation site.

The unit incorporates special preventive measures with regard to the electromagnetic compatibility and must be installed and commissioned according to the EMC instructions obtained chapter 16 Appendix.

If the device has not been operated or serviced for a period of one year or longer, it must first be inspected by a (Level 3) JK Factory Certified Technician before being put back into operation. Failure to do so may result in personal injury or property damage.



NOTE:

If a fire is suspected, immediately disconnect the power supply, as long as this is safely possible.

Continue to observe all regulations required by law, public authorities and employer's liability insurance associations, which remain unaffected by the aforementioned directions.

3.9 Signs and stickers on the device



Signs which warn of danger areas or give important information on components are attached to the device. Ensure that the instruction signs are always clearly recognizable and easily legible. Any missing instruction signs or stickers must be replaced.

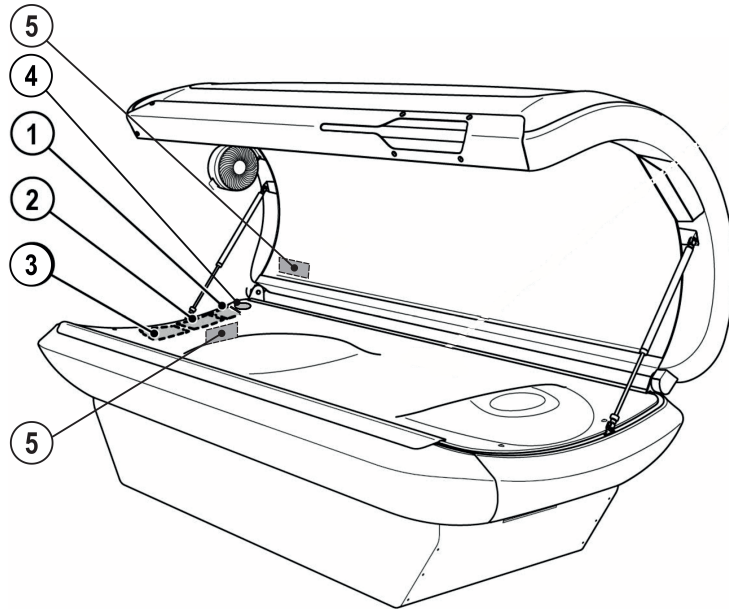

21160 / 0

1: Standards (1031046-..)

This product is in conformity with
 UL STD 482 and fulfils the
 requirements for the exempt group
 according to IEC 62471

JK - Part No: 1031046-00A

21076 / 0

2: Sticker (1014367-..)

FOR SALES, SERVICE, LAMPS & LOTIONS
 CALL:
800.643.0086

X0436704X

17197 / 2



3: Name plate (example)

MODEL-NO: JK 199 / RV 0-46		2018-01	JK Products GmbH 53604 Bad Honnef GERMANY Rottbitzer Strasse 69	ETL US
ETL RECOGNIZED ELECTRICAL EQUIPMENT				Intertek 3043354
Typ: 15803D500005180505	Voltage	Input		IP
Art.-No.: 100003443	230 V X X X phase / 60 Hz	X X KW X X A		20
SN: 1323625	230 V X X X phase / 60 Hz	X X KW X X A		

21012 / 2

4: Sticker 'Follow Operating Instructions' (1014232-..)



5: Sticker 'ESD label for sensitive components' (1029427-..)

1029427-00		ATTENTION! Composants sensibles aux décharges électrostatiques. Respecter les mesures de précaution! Exécuter les travaux portants sur les circuits imprimés uniquement par un personnel spécialisé ayant reçu une formation appropriée.	CAUTION! Components sensitive to ESD. Observe precautionary measures! The PCBs may only be worked on by specially trained personnel!
------------	--	--	--

3.10 Technical data

3.10.1 Power rating, electrical specifications and noise level



JK 199 / RV 0-46

Power consumption rating:	1400 W
Rated frequency:	60 Hz
Rated voltage:	230 V 1 phase
Rated overcurrent protection device	15 amp 2 pole*
Power supply:	SJOOW 14-3 AWG ¹⁾
Ingress protection classification:	IP20
Protection against electric shock:	Class I
Noise level inside the device:	70 dB(A)
Noise level 1m away from device:	< 71.6 dB(A)
Load on the base plate:	max. 330 lbs / 150 kg
Weight:	approx. 330 lbs / 150 kg
Max. humidity:	70%
Ambient temperature:	59-89,6°F (15-32 °C)
Max. operating altitude (above sea level):	6,500 ft (2,000 m)

* Due to high inrush current caused by the electrical components used, such as ballasts, power supplies, etc., the units must be protected by slow-blow fuses.

When using circuit breakers, make sure that they have tripping characteristic D or similar.

¹⁾ Wire size is dependent on local electrical code. Please check with your local electrician or inspector to ensure proper size is used.



NOTE:

Adaptation of the unit is required for operating altitudes greater than 6,500 ft / 2,000 m above sea level in order to guarantee trouble-free operation.



3.10.2 Dimensions

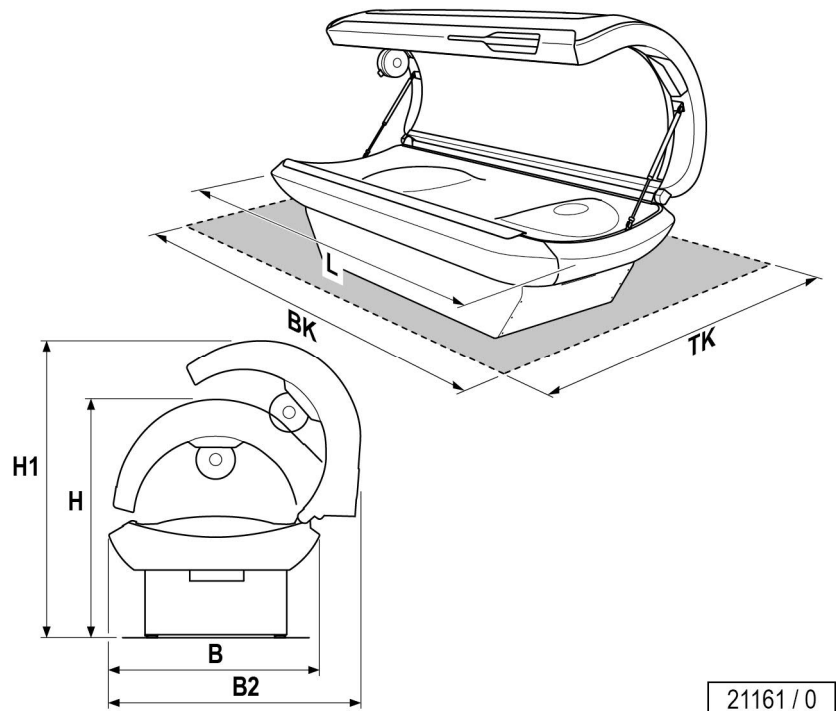

21161/0

- B = 925 mm
- H = 1093 mm
- H1 = 1322 mm
- B2 = 1118 mm
- L = 2160 mm
- BK = 2400 mm
- TK = 1500 mm

3.10.3 Lamp configuration

Not applicable for this device.

3.10.4 Accent lighting

Not applicable for this device.

3.10.5 Spare parts

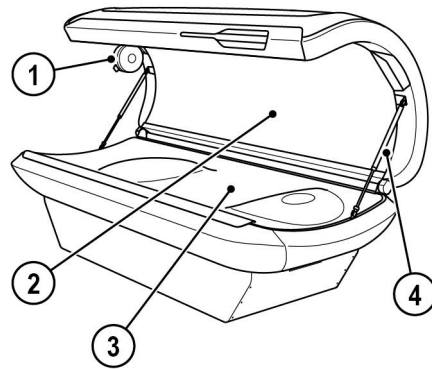

21170 / 0

Number	Description	Order-no.
1	1 Scent card	1514150-..
2	1 Canopy panel	1514013-..
3	1 Base panel	1514018-..
4	1 Gas pressure spring	1513924-..
	1 SW4 Allen key	84500-..
	1 Protective goggles	1027147-..

For more spare parts, contact Customer Service (see page 2).

4 Why you use it



4.1 Intended use

REVIVE PRO IR Laydown

This device is used for the application of near infrared and red-light technology for one person at a time.

The device may not be used by people with reduced physical, sensory or mental capabilities or who have insufficient experience and/or knowledge without supervision. A person responsible for their safety must ensure, either by supervision or instruction, that the device is used correctly and safely. If there is any doubt, use of the device by such categories of persons is forbidden! This device is only to be operated with the specified Red Light & Near Infrared LEDs or their equivalent. The usage times given in these operating instructions are valid only for the specified Red Light & Near Infrared LEDs.

Any other use shall be considered improper. The manufacturer cannot be held liable for damage or injuries resulting from this. The operator bears the sole risk for this.

Proper use also includes compliance with the manufacturer's instructions and its operating and maintenance conditions. The device may only be operated, maintained and repaired by persons familiar with these tasks and who have been informed of the dangers involved.

4.2 Skin condition

Not applicable for this device.

5 Who cannot use it



5.1 Prohibited usage

5.1.1 REVIVE system

The following people must not use the device:

- Multiple people may not use the device at the same time.
 - People with body weight of more than 330 lbs (150 kg) may not use the device.
 - Persons taking medication that increase photosensitivity should not use this device. Review medication listings and labeling prior to use.
 - No other persons are permitted in the vicinity of the cabin when using the device.
- Seek medical advice if in doubt!

5.1.2 Vibra Shape (vibration plate)

Not applicable for this device.

6 What you must do to avoid serious harm



6.1 General

DANGER – HIGH VOLTAGE!



DANGER!

You can be killed or injured by an electric shock!
Assembly and electrical connection must comply with national and local regulations.

- The device may only be assembled, installed, upgraded or repaired by authorized, trained and qualified staff.

WARNING



WARNING!

Risk of electric shock!

- To avoid risk of electric shock, this equipment must only be connected to a mains supply with protective earth grounding.

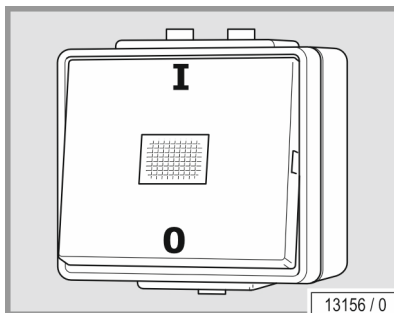

The electrical installation must have a freely accessible, all-pole disconnecting device (Master switch with clearly labelled On/Off settings, e.g. 'O' and 'I' or additional indicator light) fitted externally on the site.

DANGER – HIGH VOLTAGE!



DANGER!

You can be killed or injured by an electric shock or injured by overheating!

Danger of overheating by obstruction of the air routing.

- No modification of this equipment is allowed.

6.2 REVIVE system



WARNING!



This device emits electromagnetic fields!

EM-Emission inside device:

– 5 Hz – 2 kHz	max. 2.1 μ T (1.5 kV/m)
2 kHz – 400 kHz	max. 3.3 μ T (1.3 kV/m)
9 kHz – 30 MHz	max. 35 db μ V/m (56 μ V/m)
30 MHz – 1 GHz	max. 95 db μ V/m (56 μ V/m)
1 GHz – 6 GHz	max. 90 db μ V/m (32 μ V/m)

If you have an active implant or body worn medical device (e.g. insulin body pump, blood glucose sensor) consult your health care provider before use of this device.

6.3 Sensor

Not applicable for this device.

7 What you must do to avoid other harm



7.1 General

WARNING!



Infections can be transferred through skin contact. All items/equipment components, with which the user can come into contact during the application, must be cleaned and disinfected after every session:

- Protective goggles
- Fan
- Entry area
- Acrylic panels
- Handles and INTERIOR DISPLAY
- Use only EPA registered quaternary ammonium germicidal based detergent solution (follow product label for use-dilution), such as Lucasol One Step, to clean and disinfect the REVIVE PRO IR Laydown and its components.

7.2 REVIVE system

WARNING!



Danger of long-term consequences!

The following people must not use this device:

- Pregnant women
- People who experience any negative effects from very bright light.
- Minors should gain parental consent prior to use.
- You should stop using the system if you experience any pain, discomfort or adverse reactions.

7.3 Sensor

Not applicable for this device.

7.4 Vibra Shape - vibration plate

Not applicable for this device.

7.5 Foreseeable misuse



The following uses of the device are explicitly prohibited:

- Multiple people may not use the device at the same time.
- People with body weight of more than 330 lbs (150 kg) may not use the device.
- Persons taking medication that increase photosensitivity should not use this device. Review medication listings and labeling prior to use.
- No other persons are permitted in the vicinity of the cabin when using the device.

7.6 Obligations of the studio operator

As the operator you are responsible for providing clear operating, cleaning/disinfection and maintenance instructions. You are also responsible for ensuring the intended use and the proper operation of the device by means of training and instruction for the personnel and provision of all appropriate safety devices (including eyewear).

Your operating instructions must enable the safe use and safe operation of the device and take into account the characteristics and expertise of your company and also the national work safety and environmental protection regulations.

7.7 Staff training

As the operator you are obligated to train your personnel and instruct them in the established legal and accident prevention regulations. Ensure that your staff have understood and observe these instructions. This includes:

- information regarding intended use and foreseeable misuse
- safety instructions
- operating instructions
- cleaning/disinfection and maintenance instructions
- Please make the instructions and additional information from the manufacturer available to the staff at their workplace.
- Regularly check your staff's safety consciousness and awareness of the risks, taking into account your operating instructions.
- Please ensure that the cleaning/disinfection intervals are complied with, in particular cleaning and disinfection after every use.
- Please ensure that your staff provide your customers with appropriate advice, in particular regarding application times, possible risks and the operation of the device.

8 Risks of using this device



The following people must not use this system:

- People younger than 18
- Pregnant women
- People with epilepsy/prone to seizures
- People with limited/reduced mental capacity
- People with limited/reduced physical or sensory capabilities
- People with acute or chronic inflammation
- People with acute or chronic fever or pain

9 Benefits of using this device



REVIVE PRO IR Laydown

The REVIVE PRO IR Laydown benefits the user by enhancing a healthy lifestyle and general wellness.

10 How to decide to use this device



This device is intended only for commercial use and not for private use.

Some people are not permitted to use the device, see chapter 5.

The device may not be used by people with reduced physical, sensory or mental capabilities or who have insufficient experience and/or knowledge without supervision. A person responsible for their safety must ensure, either by supervision or instruction, that the device is used correctly and safely. If there is any doubt, use of the device by such categories of persons is to be forbidden!

11 What to do before the application



Please check for any conditions that may prohibit the use of this device – see chapters 5, 6, 8, 10.

Before the Red Light & Near Infrared LEDs turn on, you have a few minutes to prepare yourself. During the preparation time you can switch on the Red Light & Near Infrared LEDs at any time by pressing the START/STOP button.

- Remove your clothes and all jewelry.
- Remove make-up and other cosmetics.
- Remove glasses. Contact lenses can be worn under the protective goggles.
- We recommend the use of protective goggles.

12 How to use this device



12.1 How to set this device up

After commissioning and cleaning/disinfection, the device is ready for operation.

See chapter 12.5.

12.2 How to make sure the device works

Before using the device, check for damage to acrylic panels.

12.3 How to use it to treat your condition

Not applicable for this device.

12.4 How to choose correct application regimen



12.4.1 Application times

Applications per week	Moderate schedule	Intensive schedule
	[Number]	[Number]
1. Week	2	3
2. Week	2	3
3. Week	2	3
4. Week	2	3
5. Week	2	3
6. Week	2	3
7. Week	2	3
8. Week	2	3
9. Week	2	3
10. Week	2	3
11. Week	2	3
12. Week	2	3
After application:	1-2 x per week	

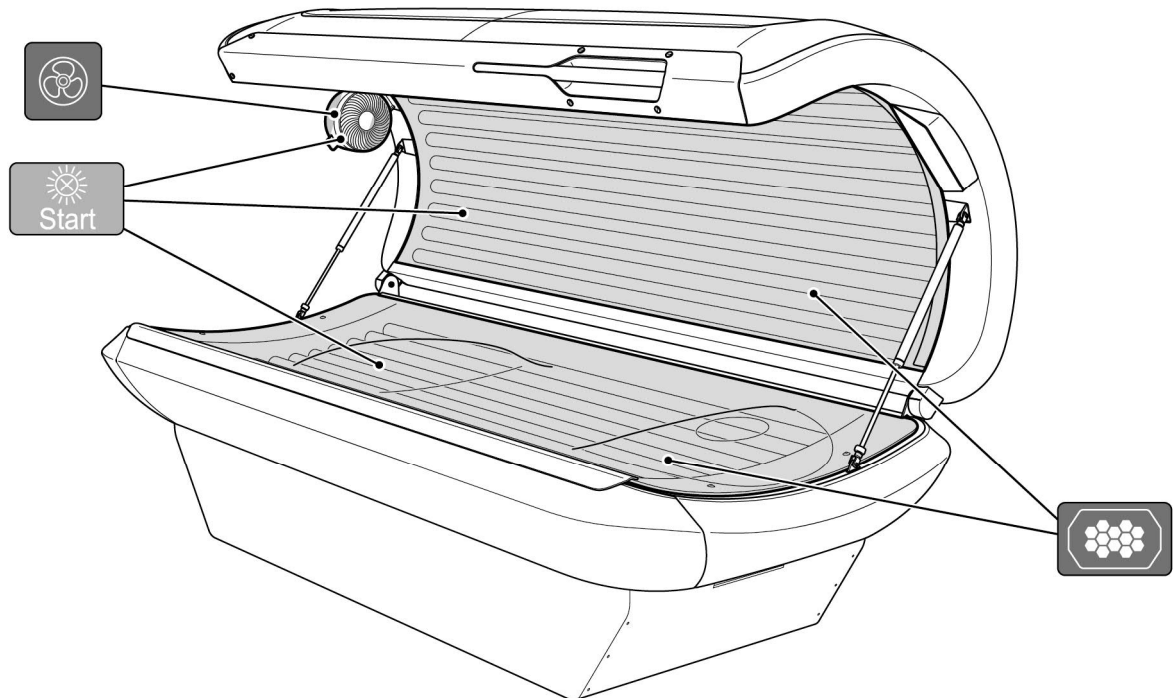
12.5 How to operate the device



21162 / 0

Symbol	Information
	START / STOP
	Body cooling
	Red Light & Near Infrared LEDs

12.5.1 Control Center

Not applicable for this device.

12.5.2 User settings overview

Not applicable for this device.

12.6 Functions

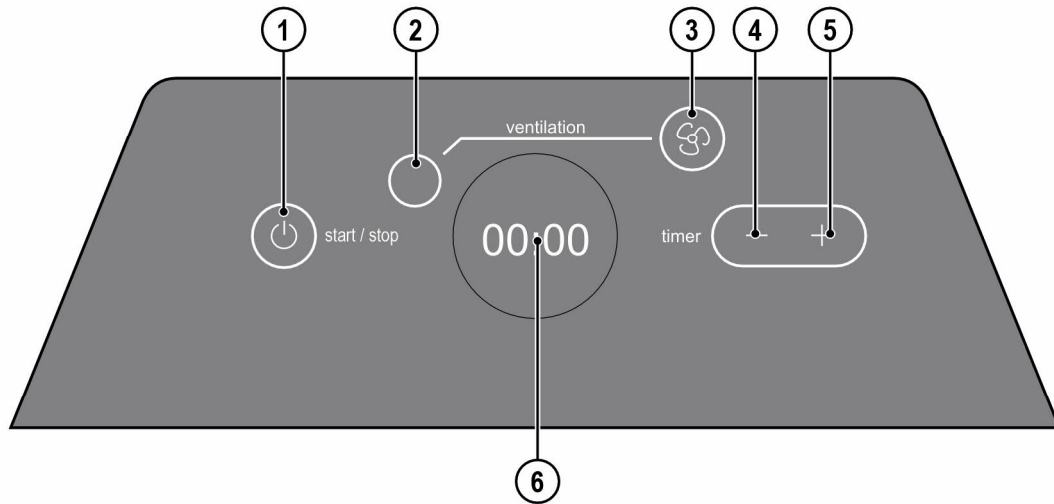











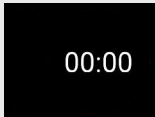
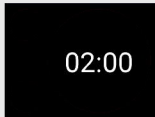

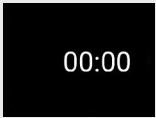
21051 / 0













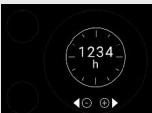

INTERIOR DISPLAY

1. START / STOP BUTTON
2. BODY COOLING (display)
3. BODY COOLING (button)
4. MINUS (button)
5. PLUS (button)
6. Application time / Fan / Red Light & Near Infrared LEDs display

12.6.1 Navigation

Icon selection / Key sequence	Description/display	Information
	PLUS button	Pressing this button changes the time setting.
	MINUS button	Pressing this button changes the time setting.
	Time setting  	In standby mode, press the plus or minus button to change the time. Pressing and holding the plus or minus button for 2 seconds makes the minutes go up or down faster.
	START/STOP button  Press the START/STOP button for 3 seconds.	Pressing the button after setting the time starts the unit. The unit stops. Unit status: Standby
	Standby without button lock.	The unit is ready for operation.
	Standby with button lock.	 Press and hold the button for 3 seconds deactivates the button lock for 60 seconds.
	BODY COOLING button   	 Pressing this button changes the fan speed. Levels 0–3

12.6.2 Info / Maintenance / Button lock

Icon selection / Key sequence	Description/display	Information
	Info-Mode	 Press and hold for 3 seconds.     or  press   
	Deactivating the button lock:	  Press for 3 seconds to lock the unit.
	Activating the button lock:	  Press for 3 seconds to unlock the unit.
	Operating hours display:	Shows the unit's total operating hours. 
	Software version display:	Shows the unit's software version.  Press briefly for the unit status: Standby mode.



NOTE:

10 seconds after the last button is pressed, the unit automatically switches to standby mode; the current settings are adopted.

12.6.3 Timer settings / External Timer setting



Icon selection / Key sequence	Description/display	Information
	Timer	<p>Press and hold for 3 seconds.</p> <p>OR</p> <p>press</p>
<p>Activating the EXTERNAL timer</p>	<p>Press for 3 seconds to change the mode.</p> <p>External timer is activated</p>	<p>Press briefly for the Standby mode.</p>

12.7 Operating display of the sensor

Not applicable for this device.

12.8 Selection of the application

Not applicable for this device.

12.9 Sun Select setting with the outer interface

Not applicable for this device.

12.10 Measurement (automatic mode)

Not applicable for this device.



12.11 Connections

Not applicable for this device.

12.12 How to use



NOTE:

Before use the device must always be cleaned and disinfected! See chapter 12.15 How to clean/disinfect.

12.12.1 How to start

The device is started with an internal timer.

You can switch on the REVIVE PRO IR Laydown at any time by pressing the START/STOP button .

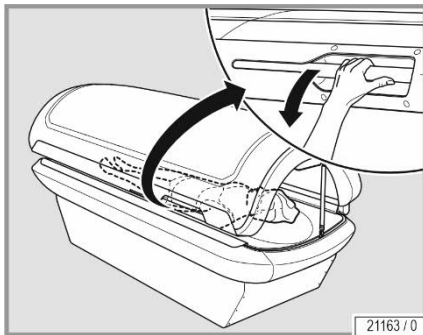

- Remove your clothes and all jewelry.
- Remove make-up and other cosmetics.
- Remove glasses. Contact lenses can be worn under the protective goggles.
- We recommend the use of protective goggles.
- Close the canopy.
- Press the START/STOP button.

Upon starting the following functions are activated:

- Red Light & Near Infrared LED
- Body cooling

12.12.2 Application tips

Behavior before, during and after an application:

Proper operation is not possible with the canopy open.

- Lie down and place your head on the headrest or as indicated by the ergonomic base panel to maintain the proper distance between skin and lamps.
- No other persons are permitted in the vicinity of the cabin when using the device.
- Remove all jewelry (including piercings) prior to the application.
- Remove cosmetics before using the device and do not use sun screen products.
- We recommend wearing protective eyewear that limits or reduces the intensity of bright light and these wavelengths during use.
- Always comply with the recommended application times.



12.12.3 How to stop

The session ends automatically after the preset time has run down.

- To interrupt a session, press and hold button START/STOP any-time during a session.
- Press START/STOP again to restart the Red Light & Near Infrared LED.



12.13 What to do after the application

12.13.1 Cleaning and disinfection

WARNING!



WARNING!

Infections can be transferred through skin contact. All items/equipment components, with which the user can come into contact during the application, must be cleaned and disinfected after every session:

- Protective goggles
- Fan
- Entry area
- Acrylic panels
- Handles and INTERIOR DISPLAY
- Use only EPA registered quaternary ammonium germicidal based detergent solution (follow product label for use-dilution), such as Lucasol One Step, to clean and disinfect the REVIVE PRO IR Laydown and its components.



NOTE:

For thorough cleaning and disinfection, the product must be allowed to remain in contact with the surface being cleaned and disinfected for a specified amount of time.

This specified amount of time depends on the cleaner/disinfectant which is used. Follow the directions for use of the cleaner/disinfectant.

After this specified application time remove remaining cleaner/disinfectant from the surfaces of the device. Use a single-pass paper towel.

Once the remaining cleaner/disinfectant has been removed, perform a visual inspection for signs of any remaining cleaning solution, or areas still soiled. If either are remaining, repeat the cleaning process until a visual inspection can be successfully completed without the need for additional cleaning.

If any of the components listed above cannot be successfully cleaned and disinfected, they must be replaced.

12.14 Safety instructions for cleaning/disinfection and maintenance



DANGER – HIGH VOLTAGE!



You can be killed or injured by an electric shock! During maintenance and service work there is a risk of touching live parts and receiving a fatal electric shock.

- The device must not be in use.
- Disconnect device from power supply before opening.
- Do not reach behind covers and do not open the device with the device switched on.
- Refit any safety devices (e.g. switches) after the work has been completed.

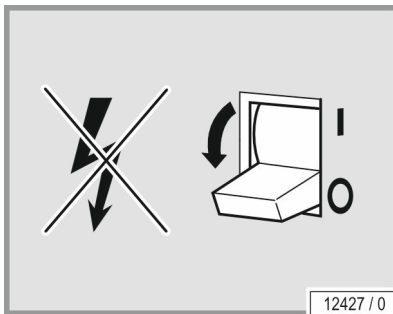

12427 / 0

If work is to be performed on the devices, they must be deenergized. That means that all live cables must be switched off.

Switching off the device alone is insufficient, as certain points may remain energized. Therefore, switch off fuses before performing any work and – if possible – remove them.

Accidental reactivation can result in serious accidents. Immediately after deenergizing, secure all switches or fuses used for deenergizing against being switched on again.

- Lock the fuse box with a padlock.

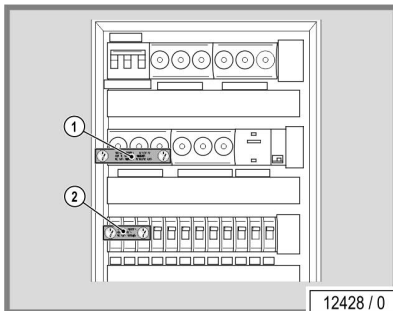

12428 / 0

In case of circuit breakers which cannot be unscrewed, a strip of adhesive tape may be applied over the actuation lever (1 + 2) with the wording 'Do not switch, danger!'.

A prohibition sign with the text:

'Work in progress!'

'Place:

'Sign may only be removed by:

must always be securely mounted immediately.

It is imperative that you, the owner and/or operator, check all components for any signs of wear which may occur through normal use.

- Observe the cleaning/disinfection and maintenance schedule specified in the tables in chapter 12.15.2 and 12.16.2.

Should you require any assistance or need additional information, please call Global Service USA at 800 445 0624, Monday through Friday 8:00 a.m. - 5:00 p.m. CT.



NOTE:

The service of the device may only be carried out by a (Level 2) JK Factory Certified Technician.



 **WARNING!**



WARNING!

Danger of burns from hot device parts!

If the REVIVE PRO IR Laydown was operated before being switched off and opened - housing parts may be hot.

- Before replacing spare parts, wait until metal parts of the device have cooled down sufficiently.

Danger of squeezing!

When opening and closing the panels and acrylics, you can squeeze your fingers.

Maintenance and care play a major role in deciding the devices performance and appearance over its useful life. Diligent compliance at the specified intervals is absolutely necessary to ensure the proper operation of your device.

The current operating hours of the parts requiring maintenance can be displayed in the Info Mode.

Please note that the device must be inspected regularly by a JK authorized representative every 12 months (from date of installation) to maintain its proper condition!



NOTE:

Please note, this device must be inspected a minimum of every 12 months from the original date of sale/installation in order to ensure all performance and safety requirements continue to be fulfilled!

Once the age of the device reaches ten (10) years from the date of manufacture, its condition must be assessed by a (Level 4) JK Factory Certified Technician before use of the device can be continued.

Failure to have this device assessment performed, may result in personal injury or property damage.

Any liability is excluded if use of the device continues ten (10) years after the date of manufacture, without the "condition assessment" having been performed.

12.15 How to clean/disinfect



WARNING!



WARNING!

Infections can be transferred through skin contact. All items/equipment components, with which the user can come into contact during the application, must be cleaned and disinfected after every session:

- Protective goggles
- Fan
- Entry area
- Acrylic panels
- Handles and INTERIOR DISPLAY
- Use only EPA registered quaternary ammonium germicidal based detergent solution (follow product label for use-dilution), such as Lucasol One Step, to clean and disinfect the REVIVE PRO IR Laydown and its components.



NOTE:

For thorough cleaning and disinfection, the product must be allowed to remain in contact with the surface being cleaned and disinfected for a specified amount of time.

This specified amount of time depends on the cleaner/disinfectant which is used. Follow the directions for use of the cleaner/disinfectant.

After this specified application time remove remaining cleaner/disinfectant from the surfaces of the device. Use a single-pass paper towel.

Once the remaining cleaner/disinfectant has been removed, perform a visual inspection for signs of any remaining cleaning solution, or areas still soiled. If either are remaining, repeat the cleaning process until a visual inspection can be successfully completed without the need for additional cleaning.

If any of the components listed above cannot be successfully cleaned and disinfected, they must be replaced.



12.15.1 Cleaning and disinfection of surfaces

Acrylic panel

NOTICE

Do not rub with a dry cloth – danger of scratching!

- Other cleaning agents, especially concentrated disinfectants or solvents (e.g. Lysoform, ethyl alcohol or other liquids containing alcohol) must never be used for cleaning. Failure to observe this voids all warranty claims.

Acrylic panels (2) & (3) referenced in section 12.15.2 'Cleaning/disinfection plan'

These panels are not in direct contact with the user, however they can become soiled if the user inadvertently touches them. If these panels are left soiled for an extended period of time, the heat and light from the Red Light & Near Infrared LED may cause the soiled areas to become permanently stained. Therefore we recommend frequently inspecting and cleaning these panels when necessary, to ensure the serviceable life of the acrylic.

- Remove fingerprints and other soiling carefully.

Plastic surfaces

For cleaning the remaining painted and unpainted plastic surfaces, it is best to simply use warm water and commercially available soft chamois leather. Never use aggressive cleaning agents containing alcohol or essential oils. These may lead, in the long run, to damages not covered by the warranty.

During cleaning a slight discoloration of the leather cloth by the rubber seals should be expected for production-related reasons.

Prevent damage to the acrylic glass and plastic surfaces.

- Remove rings, watches, bracelets etc. before starting cleaning work.

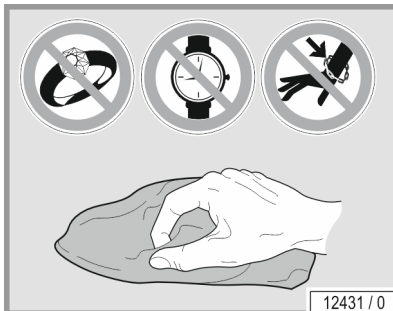

Lamps

Not applicable for this device.

12.15.2 Cleaning/disinfection plan

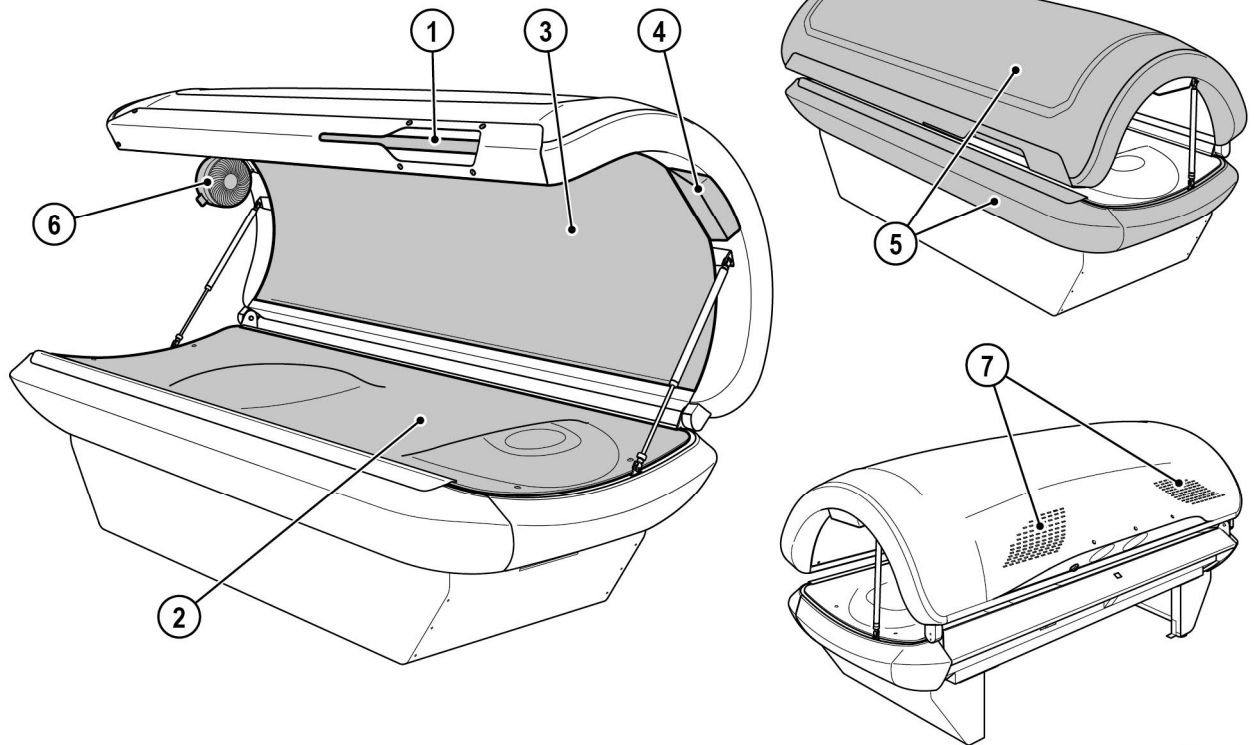

21164 / 0

Component		Interval		Activity	See page
		After each use	As necessary		
1	Handle	X		Clean and disinfect	42
2	Acrylic glass panel	X		Clean and disinfect	42
3	Canopy panel		X	Clean	42
4	INTERIOR DISPLAY	X		Clean and disinfect	42
5	Surfaces		X	Clean	42
6	Fan		X	Clean	41
	Protective goggles	X		Clean and disinfect	42
7	Ventilation slots		X	Clean (vacuum)	51



12.16 How to maintain

12.16.1 Technical modifications

The device has been constructed in accordance with current safety regulations. The illustrations and specifications on these instructions are subject to technical modifications which are required in order to improve the device.

Unauthorized modifications and changes to the device and its control unit are prohibited.

12.16.2 Maintenance schedule for wear parts



NOTE:

The service of the device may only be carried out by a (Level 2) JK Factory Certified Technician.

NOTICE

Only use OEM spare parts of the same type! The use of other parts will void the manufacturer's warranty!

Any liability is excluded in case of damage or injury proven to be the result of the use of non-genuine spare parts.

The following maintenance activities shall be performed by the studio operator or a (Level 1) JK Factory Certified Technician.

The following items are considered consumables and should be replaced as noted. Replacement of these components helps ensure continued performance of the device.

Maintenance performed by the studio operator or a JK Factory Certified Technician

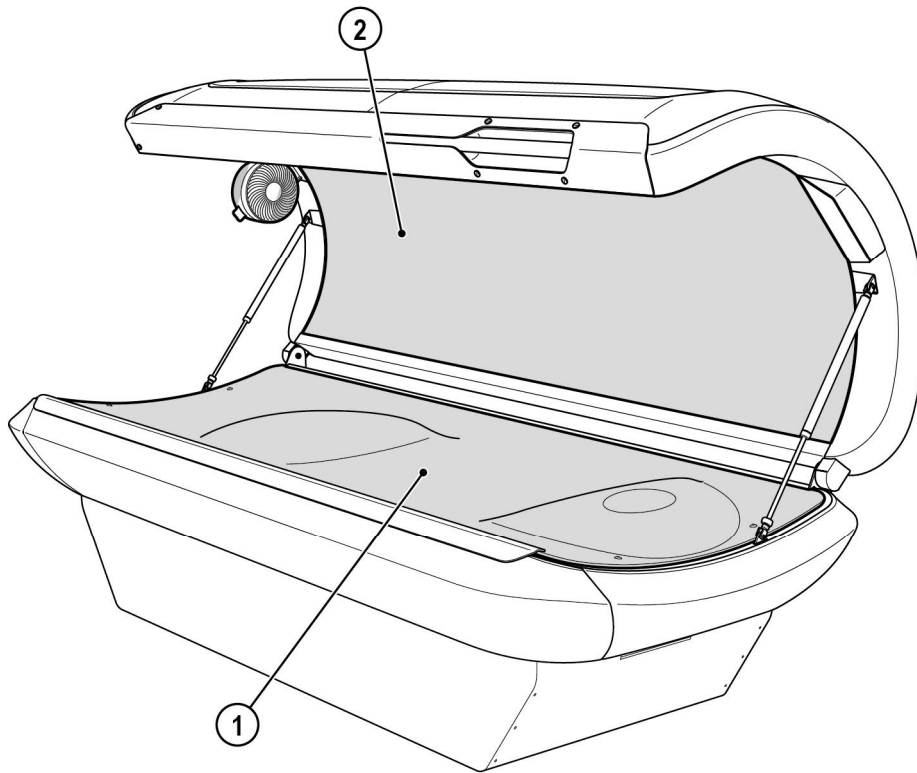

21165 / 0

Component	Interval	Activity	See page
	5000 Operating hours		
1 Acrylic panel, base	X	Replace	49
2 Acrylic panel, canopy	X	Replace	48



Maintenance performed by authorized, trained and qualified staff

⚠ WARNING!



WARNING!

Danger to persons from maintenance work that has not been carried out!

If maintenance work is not carried out, it can lead to material damage or personal injuries!

- Maintenance work may only be carried out by personnel who have been authorized, trained and qualified by JK Products & Services, Inc.!
- The operator is responsible for compliance with the maintenance intervals!

The maintenance work must be carried out in accordance with checklist 1019858-.. by a JK Factory Certified Technician at the manufacturer or by personnel who have been authorized, trained and qualified by the manufacturer.

The correctly carried out maintenance work must be entered and confirmed in checklist 1019858-...

The maintenance work must be carried out at the following intervals:

- Annually or every 2000 hours, whichever is sooner.
- After 5000 hours
- After 10 years or 20,000 hours, whichever is sooner.

Once the age of the device reaches ten (10) years from the date of manufacture, its condition must be assessed by a (level 4) JK Factory Certified Technician before use of the device can be continued.

Failure to have this device assessment performed may result in personal injury or property damage.

Any liability is excluded if use of the device continues ten (10) years after the date of manufacture, without the "condition assessment" having been performed.

12.16.3 Cleaning and maintenance work preparation

Not applicable for this device.

12.16.4 Instructions for replacing the lamps

Not applicable for this device.

Changing the chip card

Not applicable for this device.

Low-pressure lamps

Not applicable for this device.

Makrolon tubes

Not applicable for this device.

Starter

Not applicable for this device.

High pressure lamps and filter panels

Not applicable for this device.



12.16.5 Cleaning and disinfection of the sensor

Not applicable for this device.

12.16.6 Disassembly for maintenance and cleaning work

NOTICE

Acrylic panels unusable due to soiling!

Soiling on the panels is burned in by the hot and results in the long term in unserviceable panels.

- Remove fingerprints and other soiling carefully.



NOTE:

There is a risk of damage being caused to the acrylic glass panels and the operating unit and air ducts!

- Do not knock the acrylic glass panel against the operating unit.



12.16.7 Removing the canopy panel



NOTE:

The base panel must be closed before the canopy panel is dismantled.

- Release and unscrew the five screws.

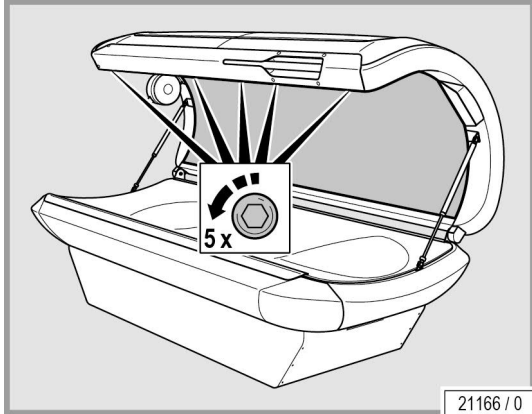

NOTE:

Remove the outside screws first and then remove the screws in the middle.

- Push the canopy panel to the rear with one hand and pull it out of the front guide.

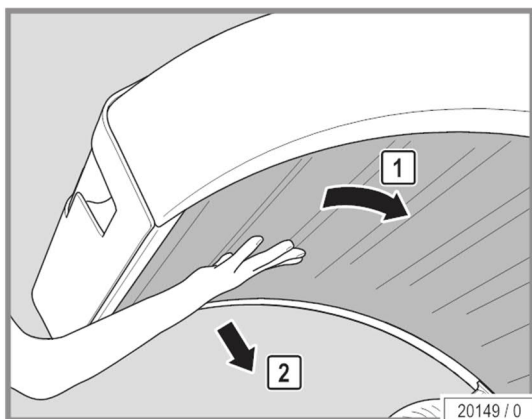

- Carefully lay the panel aside on the scratch guard.

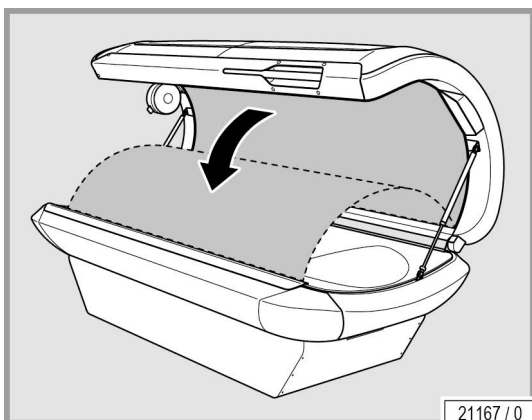

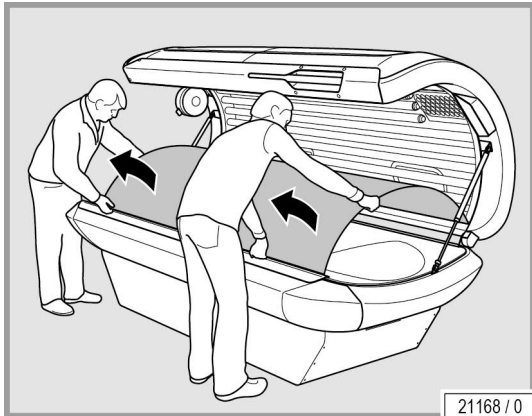

- Remove the canopy panel with the aid of a helper.

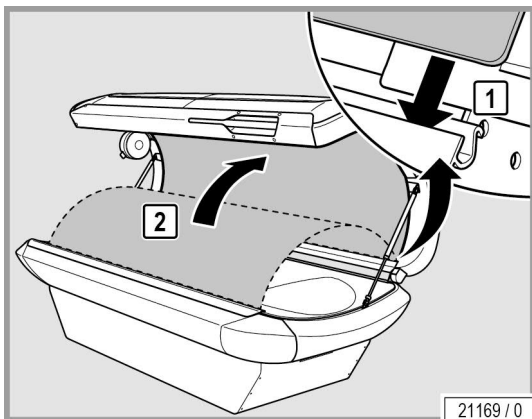

The assembly is the same process in reverse order. When assembling please note:

- Use the scratch protection.
- Carefully lay the canopy panel in the guide.
- Remove fingerprints and other soiling carefully.

12.16.8 Removing the acrylic panel

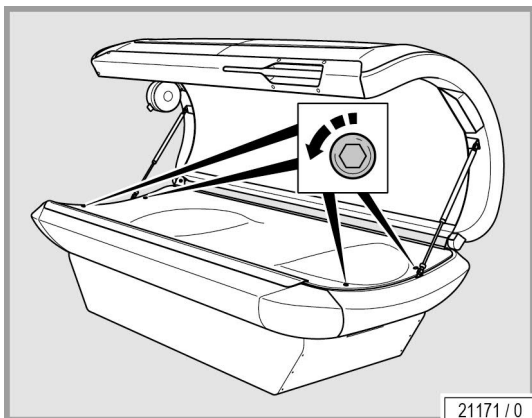

- Remove the screws and remove the washers.

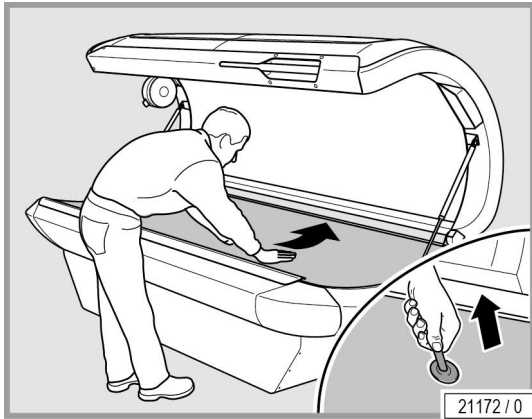

- Push the base panel to the rear with one hand and pull it out of the front guide.

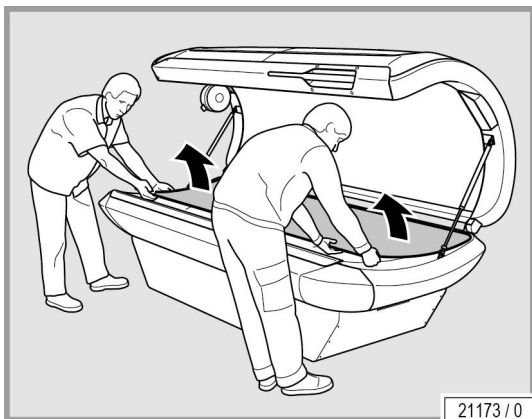

- With a second person to help you, remove the base panel and carefully place to one side.

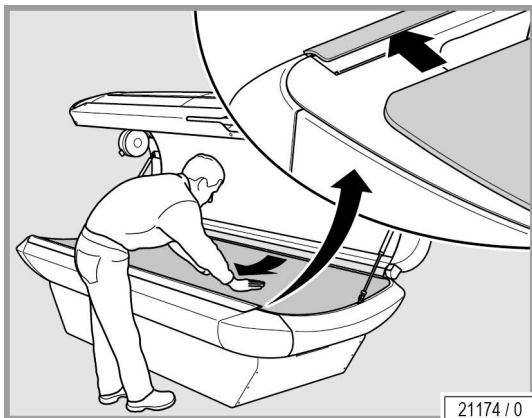

The assembly is the same process in reverse order.
When assembling please note:

- Carefully lay the panel in the guide.
- Remove fingerprints and other soiling carefully.

12.16.9 Changing the AROMA card

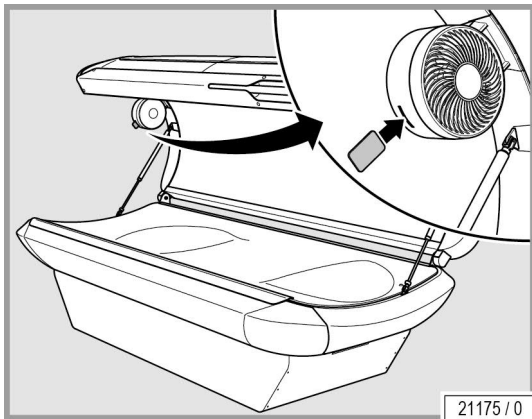

- Insert the AROMA card into the side opening on the fan.



12.16.10 Cleaning the ventilation slot

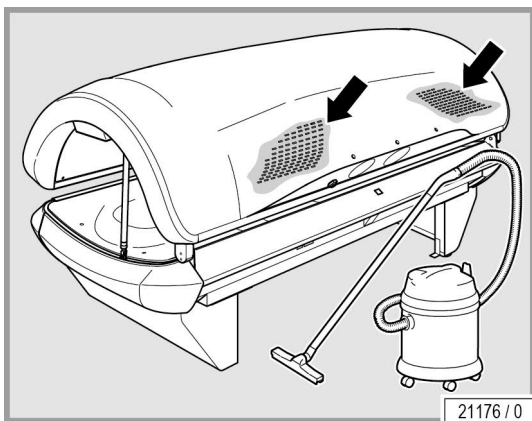

- Use a vacuum cleaner to clean the ventilation slot.

12.16.11 Cleaning or replacing lamps and filter panels in the canopy

Not applicable for this device.

12.16.12 Cleaning or replacing the lamps and filter panels in the shoulder tanner

Not applicable for this device.

12.16.13 Cleaning or replacing Ambient Light

Not applicable for this device.

12.16.14 Cleaning or replacing the canopy accent lighting

Not applicable for this device.



12.16.15 Cleaning or replacing the front panel accent lighting

Not applicable for this device.

12.16.16 Cleaning the filters

Not applicable for this device.

12.16.17 Cleaning the filter mats

Not applicable for this device.

12.16.18 Cleaning the filter mats in shoulder tanner

Not applicable for this device.

12.16.19 Air conditioning: Empty the condensation tank and clean the filter

Not applicable for this device.

12.16.20 AQUA / AROMA SYSTEM maintenance

Not applicable for this device.

Replacing the AQUA SYSTEM canister

Not applicable for this device.

Changing the AROMA canister

Not applicable for this device.

12.17 How to store the device



12.17.1 Decommissioning

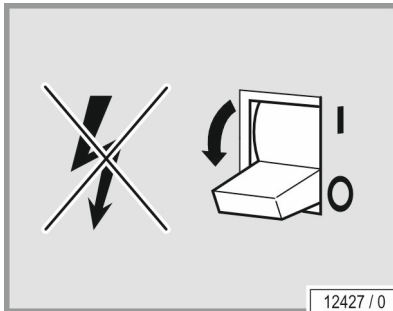

12427 / 0

The device must be disconnected from the power supply in order to temporarily or permanently decommission it.

You must abide by the legal disposal requirements when permanently decommissioning the device.

12.17.2 Storage

Store the devices in a dry location with a stable temperature. Once the device has cooled off, pack it in plastic wrapping to protect it against scratches.

- Storage temperature: between 5 °F (-15 °C) and 140 °F (+60 °C)
- Air pressure: between 794 hPa and 1060 hPa
- Relative humidity: between 30 % and 70 %

12.17.3 Disposal

Environmental regulations – disposal of batteries

Batteries contain heavy metal compounds.

Dispose of batteries according to the national waste disposal laws and in accordance with the municipal waste regulations.

Packaging

All packaging consists of 100 % recyclable materials.

Disposal of old devices

The device has been manufactured using recyclable materials.

The JK Products & Services will provide you with information on the content or potential hazards of the materials used.

Disposal of consumable supplies

Dispose of consumable supplies and their contents according to the national waste disposal laws and in accordance with the municipal waste regulations.

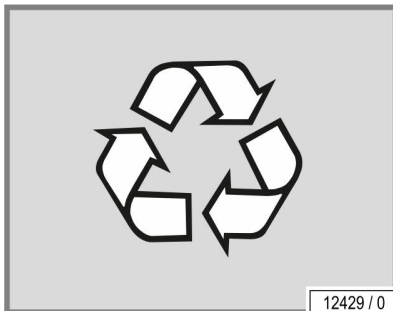

12429 / 0

13 What to do when things go wrong



- Seek medical advice if in doubt!

13.1 Troubleshooting



If the INTERIOR DISPLAY does not show 00:00 within 5 seconds:

- switch the Master switch to 'On',
- please contact Customer Service.

For authorized, trained and qualified staff:

For further technical description, please contact Customer Service (see page 2).



NOTE:

The device must never be used when the timer is defective!

14 Where you can find out more



If you have any questions, please contact Customer Service (see page 2).

15 How we studied this device



The system is built to the state of the art and the applicable safety regulations.

We reserve the right to make technical changes which are necessary to improve the system or a system component even if they deviate from pictures and information in these instructions.

16 Appendix



Not applicable for this device.

17 JK-Products, Inc. – Limited Warranty



JK-Products, Inc. warrants its products to be free from defects in materials and workmanship under intended normal use as described in the unit's Operation and Installation Instruction, for a period of one (1) year from date of sale.

This Limited Warranty applies only to the original purchaser of the equipment through JK-Products, Inc. or its authorized dealer or distributor, and is not transferable.

Global Service USA obligations under this warranty are limited to repair or replacement of any defective part without charge for that part to the original purchaser, with the following exceptions:

A Fluorescent lamps are warranted against defects for a period of thirty (30) days from date of sale.

B Only parts obtained through JK-Products, Inc., its authorized dealers or distributors may be used. Transportation costs for parts shipped to the consumer and the return of defective parts to Global Service USA are not included.

C Labor will be furnished without charge for ninety (90) days from date of purchase only. All labor and related charges must be authorized by Global Service USA prior to start of repairs, and must coincide with Global Service USA established rates and time allotment policy.

D Acrylic: Refer to Manufacturer's Acrylic Warranty Policy. It is imperative that the original customer completes and returns the enclosed warranty card within 10 days after purchase to insure valid registration and coverage for potential claims.

E Items considered to be wear items such as rubber foot mats, buttons, or other items which the user comes into contact with during normal operation of the device, are warranted for a period of 30 days from the date of purchase.

If the warranty card is not registered, proof of purchase from JK-Products, Inc. or its authorized dealer or distributor will be required prior to any consideration on warranty claims. This could result in service delays.

This warranty is extended to the individual or legal entity, whose name appears on the warranty registration card filed with Global Service USA, or whose name appears on the original sale document and may not be transferred to any other individual or legal entity.

This warranty does not apply to any failure of the product, or any parts of the product due to alterations, modifications, misuse, abuse, accident, improper maintenance, improper installation, acts of God or if the serial number on the product has been removed, altered or defaced. Adequate packaging must be used for returned goods to prevent freight damage.

There are no warranties which extend beyond the description on the face hereof. There is no express or implied warranty of fitness of merchantability.

The remedies provided in this limited warranty are the exclusive remedies provided to the purchaser by Global Service USA and are provided in substitution of all other remedies. Consequential and incidental damages are excluded.

No person, firm or corporation is authorized to obligate JK-Products, Inc. for any liability in connection with the sale or use of these goods.



17.1 Limited Acrylic Warranty

JK Products, Inc. warrants its acrylic sheets to be free from defects in material and workmanship, under intended normal use, for a period of one (1) year from date of sale of the appliance or 1,200 hours of operation whichever comes first. Due to the lotions, cosmetics, disinfectant and improper cleaners used on acrylic surfaces that cannot be controlled by JK Products, Inc., after the first thirty (30) days of warranty period acrylic will be subject to a prorated cost to the consumer.

JK Products, Inc. obligations do not include transportation charges on replacement acrylic.

JK Products, Inc. assumes no liability for the cost of removing defective sheets or installing replacement sheets, or for damage to persons or property.

To make a claim, contact an authorized dealer or distributor of JK-Products, Inc. or Global Service USA with the model number, the serial number, and the date of purchase of the bed in which the acrylic will be used.

There are no warranties which extend beyond the description on the face hereof. There is no express or implied warranty of fitness or merchantability.

The remedies provided in this limited warranty are the exclusive remedies provided to the purchaser by Global Service USA and are provided in substitution of all other remedies. Consequential and incidental damages are excluded.



NOTES:

The wooden components are only covered by a limited warranty and guarantee because they are a natural product with natural differences and deviations. For this reason, the following cannot be accepted as defects:

- the shape of wooden rings and knots
- the color and tone of wood
- natural textures or knot content
- natural shrinkage or swelling when absorbing or emitting moisture
- slight twisting
- cracking
- any dry cracks
- resin flow
- unevenness in the wood.

JK Products & Services, Inc.
411 West Washington Avenue
Suite B
Jonesboro, Arkansas 72401
Phone: 800-445-0624
Fax: 870-935-9046
E-mail: support@jkamerica.com
<http://jkproducts.us/service>

17.2 Warranty Claims



17.2.1 Policy & Procedures

1. When to file a Warranty Claim:

In the event that your REVIVE system is not functioning properly under intended normal use as described in the unit's Operation and Instruction Manual, you may then have established cause to file a Warranty Claim.



NOTE:

Both the REVIVE system and legal registered owner must meet the criteria established under JK Products, Inc. Limited Warranty as described in this manual before any Warranty Claim will be considered.

2. Where to call to place a Warranty Claim:

JK-Products, Inc. is supported nationwide by an extensive dealer/distributor network through whom the majority of our units are sold. These dealers/distributors are required by contract to stock sufficient parts to meet the various warranty and nonwarranty needs of their customers.

Therefore, in order for you to properly file a Warranty Claim, you must locate the name and phone number of the dealer/distributor through whom you purchased your unit. Normally this information can be easily located either on your paid invoice or other proof of purchase documentation that you received when taking delivery of the unit.

Next, notify the dealer/distributor of the serial number, model number and date unit was purchased. This will initiate the Warranty Claim process.

Upon determination of the problem, your dealer/distributor can then supply you with the part(s) and proper instructions to return your unit to working order.

Each dealer/distributor has their own internal procedure for handling Warranty Claims and credits.



NOTE:

JK-Products, Inc., the manufacturer, does not involve itself in the direct handling of a Warranty Claim except where mitigating circumstances apply and where required by law.



NOTE:

If a part returned to Global Service USA proves to be operational and not defective, or if product code numbers on part do not correspond with individual unit date on file with Global Service USA, then a 30% restocking fee will be charged in addition to the retail purchase price of part.

Acknowledgment of the Agreement is not required for acceptance of the foregoing stipulations.



You must comply to the instructions and warnings under chapter:

- 4.1 Intended use
- 5.1 Prohibited usage
- 6 What you must do to avoid serious harm

Any other use shall be considered improper. The manufacturer cannot be held liable for damage or injuries resulting from misuse. The operator bears the sole risk for this.

The proper use also includes compliance with the manufacturer’s instructions, operating and maintenance conditions. This device may only be operated, maintained and repaired by persons familiar with these tasks and who are aware of the dangers involved.

17.2.2 Labor Warranty Claim/Credit Procedures





Global Service USA furnishes labor without charge for a period of 90 days from date of purchase. All labor and related charges must be authorized by Global Service USA prior to start of repairs, and must coincide with Global Service USA established rates and time allotment policy.

Please contact our Service Department for authorization and billing procedures.

17.2.3 Quality inspection and acceptance form

The form can be found in the separate document ‘Quality inspection and acceptance form’ (#1014113-..) which is provided in the Technical Documentation folder.

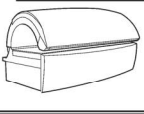
Tear here to remove page

<p>Quality Inspection and Acceptance Form. Both parties must sign the form in order for it to be valid. Upon completion, email the signed form to JK Products & Services at Questions? (800) 643-0086 QIF@JK.AMERICA.COM</p> <p>Club/Salon Name: _____ Contact: _____ Street Address: _____ City: _____ State: _____ Zip: _____ Phone Number: _____ Install Date: _____ Service Provider: _____</p> <p>Select the box next to the appropriate subsystem indicating the system is installed and functioning properly. If the device is not equipped with a particular subsystem draw a line through it.</p> <p>Lamps: <input type="checkbox"/> Body Bench <input type="checkbox"/> Body Canopy <input type="checkbox"/> Facial (HP) <input type="checkbox"/> Facial (Spaghetti) <input type="checkbox"/> Shoulder Tanner <input type="checkbox"/> Decor</p> <p>Options: <input type="checkbox"/> Skin Sensor <input type="checkbox"/> Air Conditioning <input type="checkbox"/> Aqua Fresh <input type="checkbox"/> Aroma <input type="checkbox"/> Audio System</p> <p>Select the box next to the appropriate subsystem indicating the system has been setup and adjusted. If the device is not equipped with the subsystem draw a line through it.</p> <p><input type="checkbox"/> Lifting Mechanism <input type="checkbox"/> Timer Network</p> <p>Select the box next to the operating feature and maintenance functions that have been explained to the customer or salon representative.</p> <p><input type="checkbox"/> Basic Operation <input type="checkbox"/> Accessing lamps <input type="checkbox"/> Air Filter Location <input type="checkbox"/> Feature Operation <input type="checkbox"/> The Operating Instructions, Service Tool, and Eye Protection have been provided <input type="checkbox"/> The device has been installed, electrically connected and fully operational. <input type="checkbox"/> The device has been installed, but not electrically connected all systems appear to be operational.</p> <p>Signing this form confirms the device was installed and tested both electrically and functionally by the Service Provider, any damage is indicated in the section to the right, and the selections above have been completed, explained, and understood by all.</p> <p>Service Provider Representative</p> <p>Print Name _____ Signature _____ Date _____ Salon/Club Representative</p> <p>Print Name _____ Signature _____ Date _____</p>	<p>Make/Model: _____ Please indicate here if device rebranded and labels applied. <input type="checkbox"/></p> <p>Serial Number: _____</p> <p>Please indicate (by marking an X) on the applicable illustration any damage or improper fitting decor parts.</p> <div style="display: flex; justify-content: space-around;">   </div> <div style="display: flex; justify-content: space-around;">   </div> <div style="border: 1px solid black; padding: 5px; text-align: center; font-size: 2em; margin-top: 10px;">HERE:</div> <p style="writing-mode: vertical-rl; transform: rotate(180deg); font-size: 0.8em;">Affix Name Plate from Manual!</p> <p>Acceptance testing:</p> <table style="width: 100%; border-collapse: collapse;"> <tr> <td>Equipment used: _____</td> <td>Serial Number: _____</td> <td>Calibration Due: _____</td> </tr> <tr> <td>High Voltage (Hypot) _____</td> <td>_____</td> <td>_____</td> </tr> <tr> <td>Ground Bond _____</td> <td>_____</td> <td>_____</td> </tr> <tr> <td>Ammeter _____</td> <td>_____</td> <td>_____</td> </tr> <tr> <td>Voltmeter _____</td> <td>_____</td> <td>_____</td> </tr> <tr> <td>High Voltage (Hypot) test: 1.25 KV AC / 2.5 KV DC <input type="checkbox"/> Pass <input type="checkbox"/> Fail</td> <td>_____</td> <td>_____</td> </tr> <tr> <td>Ground Bond: Less than 0.1 Ohms <input type="checkbox"/> Pass <input type="checkbox"/> Fail</td> <td>_____</td> <td>_____</td> </tr> <tr> <td>Amperage: Line 1 _____ Amperage: Line 2 _____ Amperage: Line 3 _____</td> <td>_____</td> <td>_____</td> </tr> <tr> <td>Voltage: L1 to L2 _____ Voltage: L1 to L3 _____ Voltage: L2 to L3 _____</td> <td>_____</td> <td>_____</td> </tr> </table> <p>Comments: _____ _____ _____</p>	Equipment used: _____	Serial Number: _____	Calibration Due: _____	High Voltage (Hypot) _____	_____	_____	Ground Bond _____	_____	_____	Ammeter _____	_____	_____	Voltmeter _____	_____	_____	High Voltage (Hypot) test: 1.25 KV AC / 2.5 KV DC <input type="checkbox"/> Pass <input type="checkbox"/> Fail	_____	_____	Ground Bond: Less than 0.1 Ohms <input type="checkbox"/> Pass <input type="checkbox"/> Fail	_____	_____	Amperage: Line 1 _____ Amperage: Line 2 _____ Amperage: Line 3 _____	_____	_____	Voltage: L1 to L2 _____ Voltage: L1 to L3 _____ Voltage: L2 to L3 _____	_____	_____
Equipment used: _____	Serial Number: _____	Calibration Due: _____																										
High Voltage (Hypot) _____	_____	_____																										
Ground Bond _____	_____	_____																										
Ammeter _____	_____	_____																										
Voltmeter _____	_____	_____																										
High Voltage (Hypot) test: 1.25 KV AC / 2.5 KV DC <input type="checkbox"/> Pass <input type="checkbox"/> Fail	_____	_____																										
Ground Bond: Less than 0.1 Ohms <input type="checkbox"/> Pass <input type="checkbox"/> Fail	_____	_____																										
Amperage: Line 1 _____ Amperage: Line 2 _____ Amperage: Line 3 _____	_____	_____																										
Voltage: L1 to L2 _____ Voltage: L1 to L3 _____ Voltage: L2 to L3 _____	_____	_____																										

17.3 Limited Lifetime Warranty



Global Service USA warrants specific individual components of the beauty system against defects in materials and workmanship for the life of the product. Coverage is limited to units purchased after November 1, 1994.

This warranty is restricted to the following components only:

- Steel Back Panels
- Structural Steel Frame Components
- Exterior Steel Body.



NOTE:

Components are warranted on an individual basis and not as they may affect the complete product.

Warranty coverage does not include cosmetic abnormalities such as scratches, nicks, dents, rust, oxidation of paint or other cosmetic changes that do not interfere with the designed function of the unit.

This warranty does not include failure of the product due to alteration, modifications, misuse, abuse, improper maintenance, improper installation or repair.

This warranty is not transferable and is only applicable to the original purchaser named on a completed and registered warranty record at JK-Products, Inc. headquarters.

JK Products, Inc. obligations do not include transportation charged on the shipping of new components to the customer or on the return of defective components of the manufacturer. All freight charges must be paid by the customer.

There are no warranties which extend beyond the description on the face hereof. There is no express or implied warranty of fitness or merchantability.

The remedies provided in this limited warranty are the exclusive remedies provided to the purchaser by Global Service USA and are provided in substitution of all other remedies. Consequential and incidental damages are excluded.



NOTE:

Any misuse, abuse, modification, alteration, improper maintenance, improper installation, etc. of this product or its intended use will subject said party to direct responsibility and liabilities for any and all consequences resulting from such action. Furthermore, such actions will void all warranties and may relieve Global Service USA of any liabilities relating to said product.

18 Index



A	
Air routing.....	11
Application	35
Application times.....	30
Application tips	37
B	
Base plate	
Load.....	17
C	
Changing the AROMA card.....	51
Cleaning.....	38, 41
Cleaning/disinfection	
Cleaning intervals.....	43
Commissioning	14
Control Center	31
Cosmetics	37
Customer Service.....	2
D	
Decommissioning.....	53
Definitions	6
Device description	10
Dimensions	18
Disinfection	38, 41
Disposal.....	53
E	
Electrical specifications	17
Export	9
F	
Foreseeable misuse	25
Functions.....	32
G	
Guidelines.....	9
I	
Installation location	11
Intended use.....	20

M

Maintenance schedule	
Wear parts.....	44



N

Noise level.....	17
------------------	----

O

Obligations of the studio operator.....	25
Operating altitude.....	12
Order numbers.....	19

P

Packaging.....	53
Plastic surfaces (care).....	42
Power rating.....	17
Prohibited usage.....	21
Protective goggles.....	37

R

Recycling.....	53
Removing the acrylic panel.....	49
Removing the canopy panel.....	48
Risk of injury.....	21

S

Safety measures during maintenance work.....	39
Scope of delivery.....	9
Setup location.....	12
Spare parts	
Order numbers.....	19
Staff training.....	25
Storage.....	53

T

Technical data.....	17
Transport.....	11
Troubleshooting.....	55

V

Ventilation.....	11
Ventilation slot.....	51
Vibration plate.....	21

